

NEW 2018

ITALIANO - ENGLISH



COLMIC

CHAMPION QUALITY IN FISHING TACKLE

AGGIORNAMENTO | UPDATING | MISE À JOUR | ACTUALIZACIÓN



NEW PRODUCTS

2018

INDEX

CANNE / RODS

Top Kits	4
Roubasienne	6
Margin Pole	15
Bolo	16
Fisse - Whips	19
Inglesi - Match Rods	20
Siluro - Catfish	25
Telematch	26

Surf Casting 3 Sect.	28
Surf Casting 2 Sect.	37
Telesurf	38
Telebeach	41
Barca 4 Sez. - Boat 4 Sect.	43
Barca 2 Sez. - Boat 2 Sect.	44
Barca Teleregolabile - Boat Teleadjustable	46
Barca Telescopica - Boat Telescopic	48
Big Game	50
Trolling	51

Manici di guadino - Landing net handles	53
---	----

MULINELLI / REELS

Mulinelli - Reels	56
-------------------	----

GALLEGGIANTI / FLOATS

Galleggianti - Floats	70
Antenne - Antennas	79

ABBIGLIAMENTO / CLOTHING

Abbigliamento - Clothing	80
--------------------------	----

BORSETTERIA / LUGGAGE

Borse Trevira - Trevira Bags	86
Borse PVC - PVC Bags	88

FILI / LINES

Braided Line	92
Fluorocarbon	93

PANIERI / SEAT BOXES

Panieri - Seat boxes	94
----------------------	----

NASSE E TESTE DI GUADINO KEEPNETS AND LANDING NET HEADS

Nasse - Keepnets	99
Teste di guadino - Landing Net Heads	100

ACCESSORI / ACCESSORIES

Ombrelli da esche - Bait umbrellas	100
Magic Net Series	101
Secchi e bacinelle - Buckets and basins	102
Vagli - Mesh riddles	103
Accessori vari - Accessories	105
Accessori surfcasting - Accessories for surfcasting	106
Occhiali - Glasses	108

AMI / HOOKS

Sabiki Hayabusa	110
-----------------	-----

COLMIC TECHNOLOGY

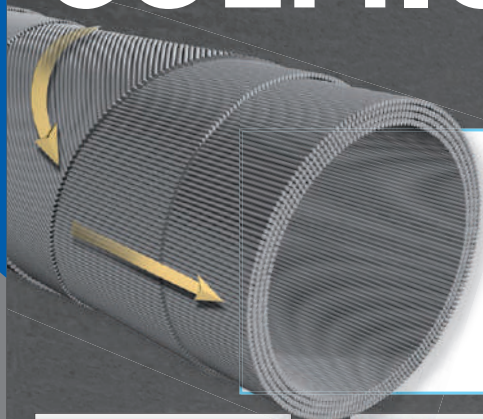

PRO FORCE
CARBON POWER DOUBLE TAP

U.L.A.F. CARBON
ULTRA LIGHT AEROSPACE FIBER

U.L.A.F. PRO FORCE è un particolare processo di stratificazione che crea una sottilissima membrana (o lamina) di carbonio composta da fibre orientate in tre direzioni. Lo speciale orientamento e l'esclusiva resina Filler Inside ad alta densità, già impiegata per l'impregnazione del carbonio U.L.A.F. donano una elasticità superiore, riducendo il peso che fino ad oggi era necessario per aumentare la capacità di assorbire urti.

PRO FORCE U.L.A.F. is a special process of stratification that creates a superfine membrane (or foil) of carbon composed of fibres arranged in three different directions. This particular orientation and the exclusive high-density Filler Inside resin, already utilized for the impregnation of the Ultra-Light Aerospace Fibre carbon, yield greater flexibility, reducing the weight that was previously required to boost the shock-absorbing capacity.

TITANIUM REINFORCE

Alla base di tutte le sezioni sono state applicate delle lamine in titanio per aumentarne la resistenza in compressione. Titanium Joint rende ogni sezione più robusta senza aggiungere pesi in eccesso.

At the base of all sections have been wrapped Titanium foil layers, that increase the resistance to compression. The Titanium Joint Part system make every section stronger without adding weight in excess.

3KR NEW
JOINT PART REINFORCE

Le RBS che adottano il sistema "3KR" possono contare sui benefici di una nuova concezione di innesto tra le sezioni (joint part). Infatti, nella Joint Part delle sezioni (Butt section compresa) è stato applicato un particolare rinforzo in carbonio con superficie 3K woven che ne conferisce un maggiore grip per ottenere degli innesti più saldi e una minore usura degli innesti stessi.

Those pole featuring the "3KR" system can count on the benefits of a new concept of joining the sections (joint part). The Joint Part of all sections (including Butt section) has been reinforced with a special carbon 3K, which provides a better grip and less usage.

TST NEW
TRANSPARENT SURFACE TREATMENT

Le basi delle nuove RBS sono state trattate con un nuovo trattamento superficiale con una ultra performante vernice "MADE in GERMANY". Il risultato è quello di averne ulteriormente migliorato la scorrevolezza tra le mani per un migliore confort in pesca e aumentato la resistenza all'abrasione e usura da agenti esterni.

The butt sections of the new poles have been treated with an ultra-performing "MADE in GERMANY" paint. This improves a better fluidity in hands for better comfort while fishing and an increased resistance to abrasion and external agents.

SST Hi-Tech
SUPER SLIDING TOUCH

Sono particolari trattamenti superficiali del carbonio che rende le sezioni porose, riducendo notevolmente l'attrito sulle sezioni stesse, tutto ciò si traduce in una maggiore scorrevolezza pescando con la roubaisienne.

This is a surface treatment of carbon designed to give the sections a porous finish which minimizes the line friction on the rod or pole. This results in superior casting performance and improved pole sliding. In case of rain or humidity it makes the line not to stick on the rod.



Il Colmic Joint Line è un sistema di riferimento che permette di allineare le sezioni sull'asse di maggiore rigidità. Questo sistema è di particolare importanza sulle RBS dove la rigidità è di primaria importanza. Con il Joint Line si aumenta la rigidità del 12%.

The Colmic Joint Line is a reference system which allows to align all section on the main rigid axis. This is mainly important on poles because of the big importance of its stiffness. Joint Line increases the stiffness of the 12%.

PERFORMANCE SECTIONS

La Performance Section è studiata per ottenere il massimo del sopra base della roubaisienne sia a 13m che a 11,50m. L'utilizzo dei migliori materiali senza influire su di essi con passaggi di levigatura, verniciatura ed etichettatura, che ne peggiorano notevolmente il rendimento in pesca (aumento il peso di circa 30g che penalizzano la rigidità e le prestazioni della sezione stessa).

The aim here is to obtain the best in term of performances from the second section of the 13.00m and 11.50m poles. In order to reach the best performances we focused on the quality of the materials avoiding all those manufacturing processes that give a better outfit but on the other hand they affect the performances. The finishing process can increase the weight of a section up to 30g so affecting the stiffness and the performances of the section.

MINI BUTT

Sono delle mini estensioni di altissima qualità che garantiscono un'impugnatura in assoluta sicurezza, studiate per essere usate su tutti gli elementi delle roubaisienne a partire dalla 4 sezione. Raccomandiamo il pescatore di usare le mini butt per evitare spiacevoli rotture delle sezioni.

Mini butts are high quality mini extensions that assure a very secure grip, mini butts fit to all the RBS pieces from the 4th section on. We recommend the angler to use the mini butt in order to minimize the risk of section breaks.

EVA CONE

Tutte le mini prolunghe sono dotate di protezioni in Neoprene da entrambe le estremità. Queste protezioni consentono di velocizzare le operazioni di innesto e disinnesco delle sezioni, di prevenire rotture accidentali e smussare il profilo dell'innesto delle Mini Butt.

All the mini extensions are gifted with Neoprene protection on both extremities. This protection permits to speed up the section en gagement and disengagement operations, prevent accidental breakage during the recovery phase, soften the Mini Butt section shape, allowing rapid deployment.

MULTI BUTT SYSTEM

Le Multi Butt sono sicuramente un attrezzo di grande utilità. In una canna a 13.00m, per esempio, la Multi Butt specifica servirà non solo come base a 13.00m, ma potrà essere utilizzata anche come base a 11.50m, e con migliori prestazioni e con quella sicurezza che non avremo mai pescando direttamente con il soprabase.

These multipurpose butts are certainly of great use. With a 13.00m pole it can serve as butt both at 13.00m and at 11.50m length with even better performances. This tool will increase the performances of your RBS and it will also give you much safety more than fishing directly with the second section.

RODS CURVE MODEL

ACTION 0

ACTION 1

ACTION 2

ACTION 3

ACTION 4

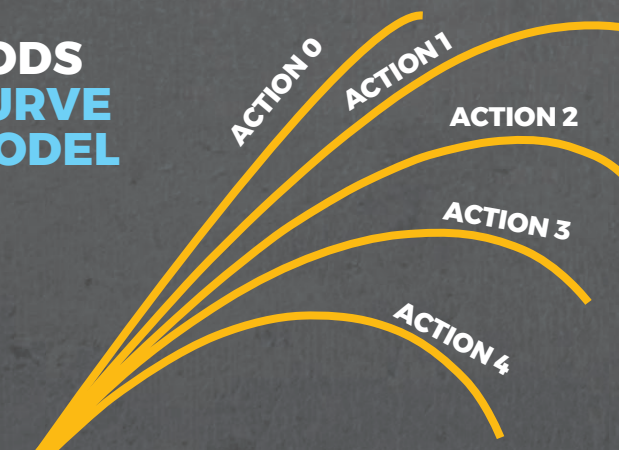

RBS ADDITIONAL COMPONENTS

2018

NEW

COLMIC

3

RBS

www.colmic.it

RBS
PROTECTOR



CODE	DESCRIPTION	COMPATIBILITY
CCXP001	PROTECTOR SERIE 03 13m	99-Z3 / 9933 / 9033 / 8033 / 7733
CCXP002	PROTECTOR SERIE 02 13m	DAITAN SERIES / 8022 / 7522 / 7322 / 7022 / 6922 / 5922
CCXP003	PROTECTOR SERIE SUPERIOR 13m	SUPERIOR / 11022
CCXP004	PROTECTOR SERIE 01 13m	AIRON F66 / PLANET CARPA / CARPA 2.0
CCXP004A	PROTECTOR SERIE 01A 13m	FIRECARP / THOR / 9501 X5 / 9401 X3 / 7401 X3 / 7001 / 6401 / QUASAR / EVO FIGHTING
CCXP005	PROTECTOR SERIE 01 11,5m	9501 X5 / - DAITAN 7000 / THOR / PLANTE CARP / CARPA 2.0 / ROXY 4000 / 9401 X3 / 7401 X3 / 7401 / 6401 / AIRON F66 / CARP RIDER / QUASAR / EVO FIGHTING / STINGER CARP

STRIPPER

code:STRIP01

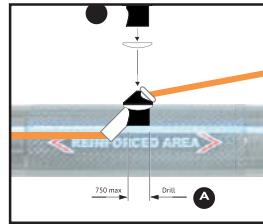
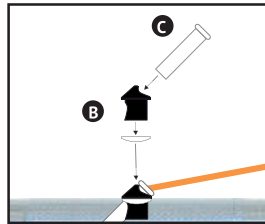
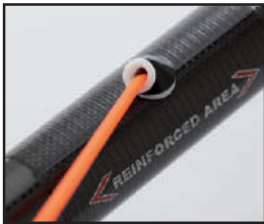

CERAMIC SLOT

5 PCS PER PACK
 ROUND (ID: 4,30MM) - CODE:STRIP02
 ROUND (ID: 5,80MM) - CODE:STRIP02A
 OVAL (ID: 4,00MM) - CODE:STRIP03

MINI BUTT

EXTRA MINI series 01 - 02 - 02A - 03

CODE	DESCRIPTION	dim.	COMPATIBILITY
CCXM001	9°sect - Series 03 -13,00m	65cm	9933 - 9033 - 8033 - 7733
CCXM002	7° & 6°sect - Series 03 -13,00m	70cm	9933 - 9033 - 8033 - 7733
CCXM003	9°sect - Series 02 - 13,00m	65cm	DAITAN 9000 - DAITAN 7000 - 8022 - 6922 - 5922 - 7022 - 6622 - 7322 - 7522
CCXM004	7° & 6°sect - Series 02 - 13,00m	70cm	DAITAN 9000 - DAITAN 7000 - 8022 - 6922 - 5922 - 7022 - 6622 - 7322 - 7522
CCXM005	8°sect - Series 01 -13,00m	90cm	EVO FIGHT - QUASAR - 7401 - 6401 - ROXY4000 - CARP RIDER THOR NX900 - 9401 X3 - 7401 X3
CCXM006	7° & 6°sect - Series 01 - 13,00m	110cm	EVO FIGHT - QUASAR - 7401 - 6401 - ROXY4000 - CARP RIDER THOR NX900 - 9401 X3 - 7401 X3
CCXM007	8°Match or 7°Carpa Series 01 -11,50m	90cm	EVO FIGHT - QUASAR - 7401 - 6401 - ROXY4000 - CARP RIDER THOR NX900 - 9401 X3 - 7401 X3
CCXM008	7° & 6°Match or 6° & 5°Carpa Series 01 -11,50m	110cm	EVO FIGHT - QUASAR - 7401 - 6401 - ROXY4000 - CARP RIDER THOR NX900 - 9401 X3 - 7401 X3
CCXM009	5° & 4°Match or 4° & 3°Carpa Series 01 - 02 - 03	70cm	For RBS Serie 01- 02 - 03
CCXM010	8°sect - Series A02 -13,00m	80cm	AIRON F66 - AIRON F55 - AIRON F44 - AIRONF33 PLANET CARPA - CARPA 2.0
CCXM011	6° & 5°sect - Series A02 -13,00m	115cm	AIRON F66 - AIRON F55 - AIRON F44 - AIRONF33 PLANET CARPA - CARPA 2.0
CCXM012	4° & 3°sect - Series A02 -13,00m	70cm	AIRON F66 - AIRON F55 - AIRON F44 - AIRONF33 PLANET CARPA - CARPA 2.0
CCXM013	7°sect - Series A02 -11,50m	80cm	AIRON F66 - AIRON F55 - AIRON F44 - AIRONF33 PLANET CARPA - CARPA 2.0
CCXM014	5° & 4°sect - Series A02 -11,50m	70cm	AIRON F66 - AIRON F55 - AIRON F44 - AIRONF33 PLANET CARPA - CARPA 2.0
CCXM015	9°sect - Series 112 -13,00m		SUPERIOR - 11022
CCXM016	7° & 6°sect - Series 112 - 13,00m		SUPERIOR - 11022
CCXM017	4° & 3°sect - Series 112 - 13,00m		SUPERIOR - 11022



HIGH QUALITY TOP KIT

QUALITY

COMPATIBILITY

- SUPERIOR
- 99-Z3 / DAITAN SERIES
- 6501
- 9501-X5 / FIRECARP
- EXPIRIA / SUPERBA
- GRINT CARP / ST 300
- MIT CARP / C 010 CLASSIC POWER

TECHNICAL SPECIFICATIONS

TOP KIT "EM" (SST - Anti Sliding)			meters	Top Id	R.Area	Ceramic	SUPERIOR	99-Z3 / DAITAN SERIES	6501	9501-X5 / FIRECARP	EXPIRIA / SUPERBA	GRINT CARP / ST 300	MIT CARP / C 010 CLASSIC POWER
◆◆◆◆◆	CCX1310A	TOP KIT 5 sect. "EM-150/00"	MATCH	6,00m	2,50mm	X	X						
◆◆◆◆◆	CCX1310B	TOP KIT 5 sect. "EM-150"	MATCH	6,00m	2,50mm	X		X		X			
◆◆◆◆◆	CCX1312A	TOP KIT 5 sect. "EM-100"	MATCH	6,00m	2,50mm	X		X		X			
◆◆◆◆	CCX1312A2	TOP KIT 5 sect. "EM-90"	MATCH	6,00m	2,50mm	X		X		X			
◆◆◆◆◆	CCX1310C	TOP KIT 4 Sect. "EM-150"	MATCH	4,50m	2,50mm	X	X	X	X	X			
◆◆◆◆◆	CCX1312A1	TOP KIT 4 Sect. "EM-100"	MATCH	4,50m	2,50mm	X	X	X	X	X			
◆◆◆◆	CCX1312A3	TOP KIT 4 Sect. "EM-90"	MATCH	4,50m	2,50mm	X	X	X	X	X			
TOP KIT "EC" (SST - Anti Sliding)													
◆◆◆◆◆	CCX1312D10A	TOP KIT 4 sect. "EC-200S"	CARPA	5,90m	3,65mm	X		X		X			
◆◆◆◆◆	CCX1312D11	TOP KIT 4 sect. "EC-150/00"	CARPA	5,90m	3,50mm	X	X						
◆◆◆◆◆	CCX1312D2	TOP KIT 4 sect. "EC-150"	CARPA	5,90m	3,50mm	X		X		X			
◆◆◆◆◆	CCX1312D5	TOP KIT 4 sect. "EC-100S"	CARPA	5,90m	3,65mm	X		X		X			
◆◆◆◆◆	CCX1312F01	TOP KIT 4 sect. "EC-95S" (3° sect. 1,50m)	CARPA	5,80m	3,65mm	X		X		X			
◆◆◆	CCX1312G1	TOP KIT 4 sect. "EC-60"	CARPA	5,70m	3,65mm	X		X		X			
◆◆◆◆◆	CCX1312D10C	TOP KIT 3 sect. "EC-200S"	CARPA	4,40m	3,65mm	X	X	X	X	X			
◆◆◆◆◆	CCX1312D3	TOP KIT 3 sect. "EC-150"	CARPA	4,40m	3,50mm	X	X	X	X	X			
◆◆◆◆◆	CCX1312D5	TOP KIT 3 sect. "EC-100S" (3° sect. 1,50m)	CARPA	4,40m	3,65mm	X	X	X	X	X			
◆◆◆◆◆	CCX1312F03	TOP KIT 3 sect. "EC-95S" (3° sect. 1,40m)	CARPA	4,30m	3,65mm	X	X	X	X	X			
◆◆◆	CCX1312G2	TOP KIT 3 sect. "EC-60"	CARPA	4,30m	3,65mm	X	X	X	X	X			
TOP KIT "PM" (SST - Anti Sliding)													
◆◆◆◆◆	CCX1313A	TOP KIT 5 sect. PM-95	MATCH	6,10m	2,50mm	X			X				
◆◆◆◆	CCX1313B	TOP KIT 5 sect. PM-80	MATCH	6,10m	2,50mm	X			X				
TOP KITS AIRON F66													
◆◆◆◆◆	CCX1312D10B	TOP KIT 4 sect. "EC-200S" Airon	CARPA	5,90m	3,65mm	X							
◆◆◆◆◆	CCX1312D4	TOP KIT 4 sect. "EC-100S" Airon	CARPA	5,90m	3,65mm	X							
◆◆◆◆◆	CCX1312F02	TOP KIT 4 sect. "EC-95S" Airon	CARPA	5,80m	3,65mm	X							
POWER KITS & OVERSIZES "M"													
◆◆◆◆◆◆	CC8799C9F	POWER KIT: OVERSIZE EC-300S POWER (no hole)	CARP	2,95m	3,65mm	X	X	X	X				X
◆◆◆◆◆◆	CC8799C9F1	POWER KIT: OVERSIZE EC-200S POWER	CARPA	2,95m	3,65mm	X	X	X	X				X
◆◆◆◆◆	CC8799C51	SUPER POWER KIT: HM55-ST (w/hole)	CARPA	2,95m	3,50mm	X	X	X	X				X
◆◆◆◆◆	CC8799C52	SUPER POWER KIT: HM55-ST (no hole)	CARPA	2,95m	3,50mm	X	X	X	X				X
◆◆◆◆	CC8799C6	POWER KIT: HM40-ST (no hole)	CARPA	2,95m	3,50mm	X	X	X	X				X
◆◆◆◆	CC8799C53	POWER KIT: HM40-ST (w/hole)	CARPA	2,95m	3,50mm	X	X	X	X				X
◆◆◆◆	CC8799C9D	POWER KIT: OVERSIZE M (no hole)	CARPA	2,95m	3,50mm	X	X	X	X				X
◆◆◆◆	CC8799C9D1	POWER KIT: OVERSIZE M (no hole)	CARPA	2,95m	3,50mm	X	X	X	X				X
◆◆◆◆	CC8799C9E	POWER KIT: OVERSIZE M SHORT (no hole)	CARPA	2,80m	3,50mm	X	X	X	X				X
◆◆◆◆	CC8799C9E1	POWER KIT: OVERSIZE M SHORT (w/hole)	CARPA	2,80m	3,50mm	X	X	X	X				X
◆◆◆	CC8799C93A	POWER KIT: OVERSIZE EC-200S HYPER 30 (no hole)	CARPA	2,90m	3,65mm	X	X	X	X				X
◆◆◆	CC8799C93B	POWER KIT: OVERSIZE EC-200S HYPER 30	CARPA	2,90m	3,65mm	X	X	X	X				X
◆◆◆	CC8799C8	POWER KIT: HYPER-30 (w/hole)	CARPA	2,95m		X	X	X	X				X
◆◆◆	CC8799C9	POWER KIT: HYPER-30 (no hole)	CARPA	2,95m		X	X	X	X				X
◆◆◆◆◆	CC8799C6B	3° sect. "FORCE-6"	CARPA	1,50m		X	X	X	X				
◆◆◆◆◆	CC8799C6C	4° sect. "FORCE-6"	CARPA	1,50m			X		X				

TOP KIT TECHNOLOGY



Si trova su tutte le seconde sezioni che supportano i filler tip e su tutte le 3° sezioni match. L'area rinforzata serve per creare un foro, senza danneggiare la sezione, dove si può applicare lo stripper.

You find the reinforced area in all the 2th sections supporting Filler tip and in all the 3th match sections. The function of the reinforced area is to avoid damaging the section in rilling the whole where to put the stripper.



TOP KIT



COMPATIBILITY

SUPERIOR	99-Z3 / DAITAN SERIES	6501	9501-X5 / FIRECARP	EXPIRIA / SUPERBA	GRINT CARP / ST 300	MIT CARP / C 010 CLASSIC POWER
----------	-----------------------	------	--------------------	-------------------	---------------------	--------------------------------

QUALITY

TECHNICAL SPECIFICATIONS

			meters	Top Id	R.Area	Ceramic	SUPERIOR	99-Z3 / DAITAN SERIES	6501	9501-X5 / FIRECARP	EXPIRIA / SUPERBA	GRINT CARP / ST 300	MIT CARP / C 010 CLASSIC POWER
◆◆◆◆◆	CC8799C9C	SUPER POWER KIT: OVERSIZE K HM55 (no hole)	CARPA	2,95m	3,50mm	X				X			
◆◆◆◆◆	CC8799C9C1	SUPER POWER KIT: OVERSIZE K HM55 (w/hole)	CARPA	2,95m	3,50mm	X				X			
◆◆◆◆◆	CC8799C9A2	POWER KIT: K-40 (no hole)	CARPA	2,90m	3,50mm	X				X			
◆◆◆◆◆	CC8799C9A3	POWER KIT: K-40 (w/hole)	CARPA	2,90m	3,50mm	X				X			
◆◆◆◆◆	CC8799C9A6	POWER KIT OVERSIZE EC-200S "K" HYPER 30 (no hole)	CARPA	2,90m	3,50mm	X				X			
◆◆◆◆◆	CC8799C9A7	POWER KIT: OVERSIZE EC-200S "K" HYPER 30	CARPA	2,90m	3,50mm	X	X			X			
◆◆◆◆◆	CC8799C9A4	POWER KIT: K-HYPER 30 (no hole)	CARPA	2,90m	3,50mm	X				X			
◆◆◆◆◆	CC8799C9A5	POWER KIT: K-HYPER 30 (w/hole)	CARPA	2,90m	3,50mm	X				X			
◆◆◆◆◆	CC9306	POWER KIT: Serie PC (no hole)	CARPA	3,10m	3,50mm	X				X			
◆◆◆◆◆	CC9306A	POWER KIT: Serie PC (w/hole)	CARPA	3,10m	3,50mm	X				X			
◆◆◆◆◆	CC8799C9A	POWER KIT: OVERSIZE K (no hole)	CARPA	2,95m	3,50mm	X				X			
◆◆◆◆◆	CC8799C9A1	POWER KIT: OVERSIZE K (w/hole)	CARPA	2,95m	3,50mm	X				X			
◆◆◆◆◆	CCX1314A	TOP KIT 3 sect. K-100	CARPA	4,40m	3,50mm	X				X			
◆◆◆◆◆	CC9305A	TOP KIT 3 sect. - PC36	MATCH	3,40m	3,50mm	X				X			
◆◆◆◆◆	CC8799C7A	3" sect. "FORCE-4 (K)"	CARPA	1,45m		X				X			
SLIM SERIES													
◆◆◆◆	CCX14XC2	POWER KIT 2 sect. SLIM Series	CARPA	3,10m	3,60mm	X					X		
◆◆◆◆	CCX14XC1	TOP KIT 4 sect. SLIM Series	MATCH	3,70m	2,20mm	X					X		
CUPPING KITS													
◆◆◆◆◆	CC8799C2A	SUPER CUPPING KIT HM-60	CARPA	2,85m	4,50mm		X	X	X				
◆◆◆◆	CC8799C2B	SUPER CUPPING KIT HM-40	CARPA	2,85m	4,50mm		X	X	X				
POWER KITS & TOP KITS													
◆◆◆	CC9606A	POWER KIT : CJO30 (no ring)	CARPA	2,65m	3,50mm	X							X
◆◆◆	CC9606B	POWER KIT : CJO30 (w/ring)	CARPA	2,65m	3,50mm	X	X						X
◆◆◆	CC9603A	TOP KIT 4 sect. (C-09/BATCARP) (no ring)	CARPA	4,10m	2,50mm	X							X
◆◆◆	CC9603B	TOP KIT 4 sect. (C-09/BATCARP) (w/ring)	CARPA	4,10m	2,50mm	X	X						X
◆◆◆	CC9604A	TOP KIT 3 sect. (C-09/BATCARP) (no ring)	CARPA	2,70m	2,50mm	X							X
◆◆◆	CC9604B	TOP KIT 3 sect. (C-09/BATCARP) (w/ring)	CARPA	2,70m	2,50mm	X	X						X
FILLER TIPS													
◆◆◆◆◆	CC8900C7	FILLER TIP MATCH SUPER LIGHT	MATCH	1,60m	2,70mm		X	X	X				X
◆◆◆◆◆	CC9307	FILLER TIP: Serie PC	CARPA	1,70m									
◆◆◆◆◆	CC8900C5	FILLER TIP "LC"	CARPA	1,50m	3,40mm		X	X	X				X
◆◆◆◆◆	CC8900C6	FILLER TIP "OVERSIZE"	CARPA	1,50m	3,20mm					X			
SINGLE SECTIONS													
◆◆◆◆◆	CC8799D1	1" sect. MATCH 350mm	MATCH	0,35m	2,50mm		X	X	X				
◆◆◆◆◆	CC8799D	1" sect. MATCH 500mm	MATCH	0,50m	2,50mm		X	X	X				
◆◆◆◆◆	CC8799D2	1" sect. MATCH 700mm	MATCH	0,70m	2,20mm		X	X	X				
◆◆◆◆◆	CC8799E	2" sect. MATCH - 1300mm	MATCH	1,30m			X	X	X				
◆◆◆◆◆	CC8799F1	3" sect. MATCH-1.400mm W/ REINF. AREA	MATCH	1,40m			X	X	X				
◆◆◆◆◆	CC8799F2	4" sect. MATCH-1.500mm (Serie EM)	MATCH	1,50m			X	X	X				
◆◆◆◆◆	CC8799F3	5" sect. MATCH-1.500mm (Serie EM)	MATCH	1,50m				X					

2018

NEW



51

RBS

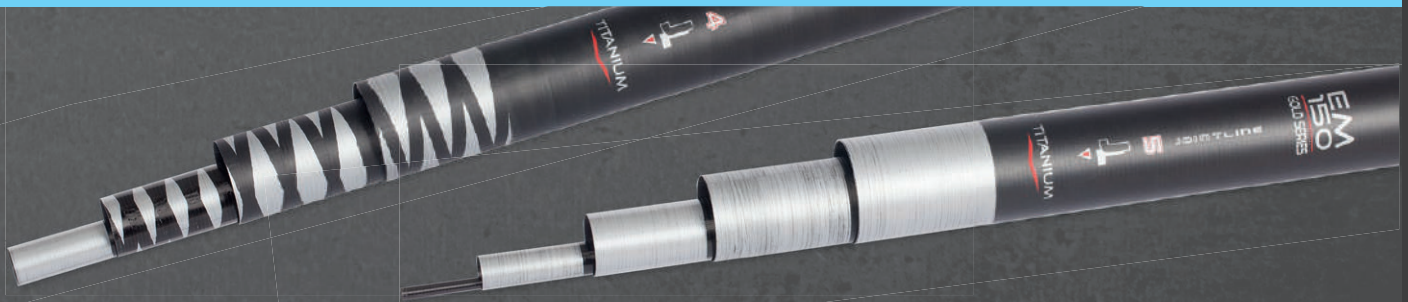

www.colmic.it

MATCH CARPA ULTRA LIGHT

SUPERIOR



MATCH - CARPA ULTRA LIGHT

Canna roubaisienne a due basi parallele. Top di gamma nella categoria light match. Rigida, super leggera e molto affidabile, la Superior è studiata appositamente per l'agonista che desidera il massimo sotto ogni punto di vista.

The Superior rod is an ultralight pole with two butt sections; it is located at the top of the light math category. The Superior rod is suitable for the most demanding agonist who desired the maximum from every point of view

PACK - RBS SUPERIOR 13m

PCS	DESCRIPTION
1	RBS SUPERIOR (13m) (9sect. - Ø 42,00 mm)
1	Mini Butt 9" (60cm) - Put-In Multi Butt (13&11,5m)
1	Mini Butt 7"6" (60cm) - Reverse (9,60m & 8,00m)
1	Mini Butt 5"4" (60cm) - Reverse (6,50m & 5,00m)
4	Top Kit 5 sect. EM-150/00 (6,05m)
1	3" section "FORCE-6" (1,50m)
1	SUPER CUPPING KIT HM-60
8	PVC Tubes
1	DURO ROD HOLDER: RBS XXL (2,00m)

code: CCX100P01



ADDITIONAL MINI EXTENSION

NOT INCLUDED - 85cm - 9"sect. (11,50m) - code:CCX80PM



3KR
JOINT PART REINFORCE



DURO ROD HOLDER RBS XXL



MATCH CARPA

99-Z3

MATCH - CARPA

Top di gamma a 3 basi parallele nella categoria Match-Carpa si presenta rigidissima, potente e affidabile, con un peso molto contenuto. Una canna indistruttibile per gli agonisti più esigenti.

Top of the range with 3 parallel butt sections in the Match-Carp range, it is very rigid, powerful and reliable, with a very contained weight. An indestructible rod for the most demanding competitor.



PACK - RBS 99-Z3 13m

PCS	DESCRIPTION
1	RBS 99-Z3 (13m) (9sect. - Ø 42,30 mm)
1	Mini Butt 9" (60cm) - Put-In Multi Butt (13&11,5m)
1	Mini Butt 7"/6" (60cm) - Reverse (9,60m & 8,00m)
1	Mini Butt 5"/4" (60cm) - Reverse (6,50m & 5,00m)
4	Top Kit 5 sect. EM-150 (6,05m)
1	3" section "FORCE-6" (1,50m)
1	SUPER CUPPING KIT HM-60
9	PVC Tubes
1	DURO ROD HOLDER: RBS XXL (2,00m)

code: CCX101P01



ADDITIONAL MINI EXTENSION

NOT INCLUDED - 85cm - 9"sect. (11,50m) - code:CCX81PM



DURO ROD HOLDER RBS XXL



2018

NEW

COLMIC

RBS 7

www.colmic.it

MATCH CARPA

DAITAN 9300

XXI
MATCH - CARPA

Top di gamma nella categoria Match-Carpa con 2 basi parallele, leggera, rigidissima ed altrettanto robusta. Ha un diametro sottile, un peso ridotto e una reattività senza pari.

Two base sections pole. The rod is the top of the Match-Carpa category, light and stiff at the same time. It has a thin diameter with a reduced weight and an incomparable reactivity.

RBS DAITAN 9300 13m

PCS	DESCRIPTION
1	RBS DAITAN 9300 (13m) (9sect. - Ø 44,70 mm) + 2 PVC tubes
1	Mini Butt 9" (65cm) - Put-In Multi Butt (13&11,5m)
1	Mini Butt 7"/6" (60cm) - Reverse (9,60m & 8,00m)

code: CCX102A
PACK - RBS DAITAN 9300 13m

PCS	DESCRIPTION
1	RBS DAITAN 9300 (13m) (9sect. - Ø 44,70 mm)
1	Mini Butt 9" (65cm) - Put-In Multi Butt (13&11,5m)
1	Mini Butt 7"/6" (60cm) - Reverse (9,60m & 8,00m)
3	TOP KIT 5 sect. "EM-100" (6,00m)
1	SUPER CUPPING KIT HM40
1	3' Sezione Force-4 (1,50m)
7	PVC Tubes
1	ROD HOLDER: RBS XXL (2,00m)

code: CCX102AP

ADDITIONAL MINI EXTENSION

NOT INCLUDED - 85cm - 9"sect. (11,50m) - code:CCX83PM



ROD HOLDER RBS XXL



MATCH CARPA

DAITAN 8000



MATCH - CARPA

Top di gamma nella categoria Match-Carpa con 2 basi parallele, un gradino inferiore rispetto alla sorella, della quale però conserva tutte le caratteristiche di leggerezza, rigidità e robustezza.

2 base sections pole. The rod is the top of the category Match-Carpa, one step below her sister from which it maintains all the characteristics of light weight, stiffness and strength.

RBS DAITAN 8000 13m

PCS	DESCRIPTION
1	RBS DAITAN 8000 (13m) (9sect. - Ø 44,70 mm) + 2 PVC tubes
1	Mini Butt 9° (65cm) - Put-In Multi Butt (13&11,5m)
1	Mini Butt 7°/6° (60cm) - Reverse (9,60m & 8,00m)

code: CCX103A

PACK - RBS DAITAN 8000 13m

PCS	DESCRIPTION
1	RBS DAITAN 8000 (13m) (9sect. - Ø 44,70 mm)
1	Mini Butt 9° (65cm) - Put-In Multi Butt (13&11,5m)
1	Mini Butt 7°/6° (60cm) - Reverse (9,60m & 8,00m)
3	TOP KIT 5 sect. "EM-100" (6,00mt)
1	SUPER CUPPING KIT HM40
1	3° Sezione Force-4 (1,50mt)
7	PVC Tubes
1	ROD HOLDER: RBS XL (2,00m)

code: CCX103AP



ADDITIONAL MINI EXTENSION

NOT INCLUDED - 85cm - 9°sect. (11,50m) - code:CCX83PM

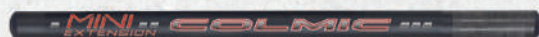

3KR
JOINT PART REINFORCE



ROD HOLDER RBS XL



2018

NEW



RBS

www.colmic.it

SUPER SPECIMEN



FIRE CARP

SPECIMEN

XXXT

Top di gamma per la pesca SPECI MEN in due basi parallele, rigidissima, potente e affidabile, con un peso contenuto.

Top of the range for SPECIMEN fishing in two parallel butt sections, very rigid, powerful and reliable, with a contained weight.

PACK - RBS FIRECARP 13-11,5m

PCS	DESCRIPTION
1	RBS FIRECARP (13-11,5m) (8sect. - Ø 46,60 mm)
1	Mini Butt 8" (85cm) - Put-In Multi Butt (13&11,5m)
1	Mini Butt 6"/5" (60cm) - Reverse (9,50m & 7,80m)
4	POWER KIT: OVERSIZE K-40 (wo/hole)
1	3" Sezione Force-4 (1,50mt)
7	PVC Tubes
1	DURO ROD HOLDER: RBS XXL (2.00m)

code: CCX89A

3KR
JOINT PART REINFORCE

DURO ROD HOLDER RBS XXL

MULTI BUTT SYSTEM

CARPA SPECIMEN

9501 X5

CARPA - SPECIMEN

XXTi

Top della linea da carpa della casa Colmic, queste canne si distingueranno per la loro leggerezza abbinata ad una grande rigidità e ad una potenza assoluta. Canna perfetta per il pescatore più esigente che è interessato ad un attrezzo che esprime il massimo delle prestazioni e i benefici dei migliori materiali utilizzati per le canne più prestigiose della linea match.

This rod is at the top of the carp pole series. This rods is featured by lightness combined with a great stiffness and a great power. They are destined to the most demanding angler interested in buying a top tackle able to express the maximum performances, thanks to the most evolutionary technologies and to the best materials used for the match's rod line.

PACK - RBS 9501 X5 13m

PCS	DESCRIPTION
1	RBS 9501 X5 (13m) (8sect. - Ø 46,60 mm)
1	Mini Butt 8" (65cm) - Put-In Multi Butt (13&11,5m)
1	Mini Butt 7"/6" (65cm) - Reverse (11,50m & 9,80m)
4	POWER KIT: OVERSIZE K-40 (wo/hole)
1	3" Sezione Force-4K (1,50mt)
6	PVC Tubes
1	DURO ROD HOLDER: RBS XL (2.00m)

code: CCX88A

PACK - RBS 9501 X5 11,50m

PCS	DESCRIPTION
1	RBS 9501 X5 (11,50m) (7sect. - Ø 45,00 mm)
1	Mini Butt 7" (65cm) - Put-In Multi Butt (13&11,5m)
1	Mini Butt 6"/5" (105cm) - Reverse (11,50m & 9,80m)
4	POWER KIT: OVERSIZE K-40 (wo/hole)
1	3" Sezione Force-4K (1,50m)
6	PVC Tubes
1	DURO ROD HOLDER: RBS XL (2.00m)

code: CCX88B



DURO ROD HOLDER RBS XL



2018

NEW

COLMIC

RBS

www.colmic.it

HIGH POWER ULTRA SLIM

SUPERBA

XT

SPECIAL CARP - ULTRA SLIM

La Superba è più sottile di tutta la gamma. Studiata appositamente per sopportare le sollecitazioni più gravose, è in grado di sostenere ogni genere di prova. L'impiego di materiali di alta qualità e la calciatura ultra slim le conferiscono una leggerezza ed una maneggevolezza davvero eccellenti, rendendola quindi adatta anche all'utilizzo in canale con assetti più light.

The Superba pole is the slimmest of the whole assortment. Expressly developed for heavy duty fishing, the Superba can handle any heavy duty fishing situation. The use of high quality materials and the slim profile make this pole exceptionally light and maneuverable, will perfectly perform also in canal fishing on lighter rigs.

SUPERBA 10m	
PCS	DESCRIPTION
1	RBS SUPERBA (10m) (8sect. - Ø 34,90 mm)
1	Mini Butt 8° (100cm)
1	Velvet Cloth Bag

code: CCX1410XA

EXPIRIA

XT

SPECIAL CARP- ULTRA SLIM

Roubaisienne da carpa con un diametro molto sottile, prodotta in carbonio alto modulo U.L.A.F. CARBON "PRO FORCE", è talmente robusta da poter essere utilizzato senza alcun limite ed assolutamente leggero e maneggevole.

Carp-pole with a slim diameter base. It's made in high module U.L.A.F CARBON PRO FORCE, with very strong material that, while being light and handy, it can certainly be used in any situation.

EXPIRIA 10m	
PCS	DESCRIPTION
1	RBS EXPIRIA (10m) (8sect. - Ø 34,90 mm)
1	Mini Butt 8° (100cm)
1	Velvet Cloth Bag

code: CCX15XA



SPECIAL CARP

GRINT CARP

SPECIAL CARP

Roubaisienne potente e affidabile, è adatta a gli specimen più esigenti. Canna Davvero indistruttibile.

Powerful and reliable Roubaisienne, adapted to all the most exacting specimens. A really indestructible rod.

GRINT CARP

code	DESCRIPTION
CCXX43A	GRINT CARP (9m) + (Mini Ext.Rev. 100cm 6' (9m) - 5' (7,50m))
CCXX43B	GRINT CARP(10m) + (Mini Ext.90cm (10m))

CLASSIC POWER

SPECIAL CARP

Canna studiata per la pesca di grosse carpe sotto sponda. Caratteristiche principali, sono l'estrema potenza ed affidabilità anche pescando con elastici e nylon sostenuti. Praticamente indistruttibile!!

Roubaisienne poles developed for the bank fishing of big carp. Their most striking features are extreme power and reliability, even when fishing with large-size elastics and nylons. It is, in effect, practically indestructible!!

CLASSIC POWER

code	DESCRIPTION
CC9702A	CLASSIC P. (9m) + (Mini Ext.Rev. 80cm 7' (9m) - 6' (7,80m))
CC9702B	CLASSIC P. (8m) + (Mini Ext.Rev. 80cm 6' (8m) - 5' (6,20m))
CC9702C	CLASSIC P. (6,5m) + (Mini Ext.Rev. 80cm 5' (6,50m) - 4' (4,80m))



SPECIAL CARP

MITCARP

SPECIAL FORCE

RBS corta, studiata appositamente per la pesca delle grosse carpe sotto sponda. Una estrema potenza, associata ad una affidabilità oltre la norma, anche nel caso in cui si utilizzino elastici e nylon di dimensioni eccezionali. Indistruttibile!

RBS rod, expressly developed for big carp fishing on the hedge. This pole are strongness matched to a great reliability, even using very large diameters nylons and big elastics. An indestructible pole. Equipped by reversible mini butts, usable on the different sections.

MITCARP	
code	DESCRIPTION
CC9701A	MITCARP (9,2m) + (Mini Ext.Rev. 80cm 6"(9,20m) - 5"(7,80m))
CC9701B	MITCARP (7,8m) + (Mini Ext.Rev. 80cm 5"(7,80m) - 4"(6,40m))
CC9701C	MITCARP (6,4m) + (Mini Ext.Rev. 80cm 4"(6,40m) - 3"(5,00m))



STS-300

SPECIAL CARP

Potente, affidabile e indistruttibile, questa rbs nasce per le pesche più gravose nei carpodromi.

Powerful reliable and indestructible, these Roubaisienne pole have been conceived to address the most hefty fish in the carp fisheries.

STS - 300	
code	DESCRIPTION
CCXX44A	STS 300 (9m) + (Mini Ext.Rev. 100cm 6"(9m) - 5"(7,50m))
CCXX44B	STS 300(10m) + (Mini Ext.Rev. 100cm 7"(10m) - 6"(8,60m))



C-010

SPECIAL CARP

Canna studiata per la pesca di grosse carpe sotto sponda. Caratteristiche principali, sono l'estrema potenza ed affidabilità anche pescando con elastici e nylon sostenuti. Praticamente indistruttibile!!

Roubaisienne poles developed for the bank fishing of big carp. Their most striking features are extreme power and reliability, even when fishing with large-size elastics and nylons. It is, in effect, practically indestructible!!

C-010	
code	DESCRIPTION
CC9703A	C-010 (9m) + (Mini Ext.Rev. 80cm 7"(9m) - 6"(7,80m))
CC9703B	C-010 (8m) + (Mini Ext.Rev. 80cm 6"(8m) - 5"(6,20m))
CC9703C	C-010 (6,5m) + (Mini Ext.Rev. 80cm 5"(6,50m) - 4"(4,80m))



COLMIC

9,20m

3000

MITC CARP

SPECIAL FORCE

RBS

10m

CARPA STS - 3000

RBS HIGH POWER HIGH PERFORMANCE

COLMIC

900m

CARP EXPERIENCE

C-010

SPECIAL FORCE

RBS HIGH POWER HIGH PERFORMANCE

COLMIC

SPECIAL CARP

MARGIN POLE

SPONDA PLUS

XT

NO LIMIT

Mini roubaisienne studiata appositamente per il sotto sponda e dotata di tutte le caratteristiche necessarie a questo tipo di pesca. La canna base, in due sezioni, è lunga 3.00m ed ha in dotazione 2 prolunghe che la portano rispettivamente a 3.70 e 4.80m.

Mini roubaisienne specially designe for bank fishing and has duly equipped it with all the features necessary for this type of fishing. The basic rod, in two sections, is 3 metres long, and comes complete with two extensions that allow lengths of, respectively, 3.70 and 4.80 m

CODE	Length (m)	Casting W. (g)	cl.Length (cm)	Weight (g)	Diameter (mm)	Sect
CASP80A	3/3,70/4,80	NO LIMIT	156	403	18,70	4



EXTENSION 75cm

COLMIC

3.70-4.80m

NO LIMITS

SPONDA Plus

COLMIC

4.10-4.80m

NO LIMITS

SPONDA Plus

COLMIC

EXTENSION 120cm

SPONDA Plus

NO LIMITS

2018

NEW

COLMIC

5

RBS

www.colmic.it



BOLO HIGH QUALITY

2018

NEW

COLMIC

16

CANNE \ RODS

www.colmic.it



FIUME 160



MEDIUM - ACTION 2

Leggera e bilanciata è ideale per la pesca in passata e in mare con terminali medio sottili.

Light and balanced, the rod is perfect for river or saltwater fishing, with light hook lengths.

CODE	Length (m)	Casting W. (g)	cl.Length (cm)	Weight (g)	Diameter R/S (mm)	Sect
CAFI90A	5,00	16	141	150	18,70	5
CAFI90B	6,00	16	144	225	21,00	6
CAFI90C	7,00	16	145	310	23,50	7
CAFI90D	8,00	16	147	435	26,00	8



FIUME 180



MEDIUM - ACTION 2

Leggera e bilanciata è ideale per la pesca in passata e in mare, con terminali medio sottili.

Light and balanced, the rod is perfect for river or saltwater fishing, with light hook lengths.

CODE	Length (m)	Casting W. (g)	cl.Length (cm)	Weight (g)	Diameter R/S (mm)	Sect
CAFI82B	6,00	18	142	220	21,60	6
CAFI82C	7,00	18	146	295	23,50	7
CAFI82D	8,00	18	148	375	25,80	8



HIGH QUALITY COMPONENTS



SERIES: YD1
ULTRA LIGHT GUIDE
 LEG: MEDIUM
 STONE: STAINLESS STEEL
 FRAME COLOR: FROSTED GUN SMOKE



SERIES: YD1
ULTRA LIGHT GUIDE
 LEG: MEDIUM
 STONE: STAINLESS STEEL
 FRAME COLOR: BLACK



HIGH PERFORMANCE



BOLO HIGH POWER

MAX FIGHT NX



SUPER STRONG - ACTION 1

Canna con un casting da 100g che permette lanci a lunga distanza e un riserva di potenza in fase di combattimento con pesci di grossa taglia.

Rods with a 100g casting weight that allows even long-distance casts and a power reserve for the battle phase even with big fish.

CODE	Length (m)	Casting W. (g)	cl.Length (cm)	Weight (g)	Diameter R/S (mm)	Sect
CAMA97A	5,00	100	135	310	21,00	5
CAMA97B	6,00	100	138	420	24,00	6
CAMA97C	7,00	100	140	585	28,00	7



DARK POWER



SUPER STRONG - ACTION 0

Canna dotata di potenza ed affidabilità straordinarie. Ideale per combattimenti con prede di grossa taglia.

Rod given to extraordinary power and reliability Ideal for fighters against large prey.

CODE	Length (m)	Casting W. (g)	cl.Length (cm)	Weight (g)	Diameter R/S (mm)	Sect
CADAR01A	5,00	100	140	350	24,50	5
CADAR01B	6,00	100	140	470	27,60	6
CADAR01C	7,00	100	142	630	31,20	7



KOMBAT ROCK



SUPER STRONG - ACTION 0

Canna dotata di potenza ed affidabilità straordinarie. Ideale per combattimenti con prede di grossa taglia.

Rod given to extraordinary power and reliability Ideal for fighters against large prey.

CODE	Length (m)	Casting W. (g)	cl.Length (cm)	Weight (g)	Diameter R/S (mm)	Sect
CAK01A	5,20	100	137	360	24,50	5
CAK01B	6,20	100	137	480	27,60	6
CAK01C	7,20	100	138	640	31,20	7



LIFT-UP 9KG

LIFT-UP 9KG

LIFT-UP 9KG

HIGH POWER

HIGH QUALITY COMPONENTS

SERIES: OS
LEG: SHORT
STONE: SIMIL SIC
FRAME COLOR: BLACK



SEA-GUIDE
SERIES: XY
LEG: SHORT
STONE: SIC
FRAME COLOR: FROSTED GUN SMOKE



SEA-GUIDE
SERIES: XDM
LEG: MICRO GUIDES
STONE: SIC
FRAME COLOR: GUN SMOKE



2018

NEW

COLMIC

CANNE \ RODS 17

BOLO HIGH QUALITY

SEVEN KEY

XT
MEDIUM - ACTION 2

Canna bolognese bilanciata, leggera e sottile, è ideale per la pesca in passata o dalla scogliera.

Balanced, light and thin bolognese rod, it is ideal for fishing in the fast water or from the rocks.

CODE	Length (m)	Casting W. (g)	cl.Length (cm)	Weight (g)	Diameter R/S (mm)	Sect
CASE50A	5,00	20	136	225	20,50	5
CASE50B	6,00	20	137	299	23,30	6
CASE50C	7,00	20	139	408	26,20	7
CASE50D	8,00	20	140	506	29,10	8



CONCORD

XS
MEDIUM STRONG - ACTION 2

Canna bolognese bilanciata, leggera e reattiva, ideale per la pesca a distanza e capacità di gestire terminali di diametro anche sostenuto.

It is a balanced, thin, light and reactive Bolognese rod for distance fishing and in all the circumstances where it takes a certain robustness and a certain skills to handle the diameter tips sometimes heavy.

CODE	Length (m)	Casting W. (g)	cl.Length (cm)	Weight (g)	Diameter R/S (mm)	Sect
CACO70A	5,00	20	136	218	20,50	5
CACO70B	6,00	20	136	302	22,80	6
CACO70C	7,00	20	138	395	25,20	7



HIGH QUALITY COMPONENTS



SERIES: YGS
LEG: MEDIUM
STONE: SIMIL SIC
FRAME COLOR: BLACK

COLMIC REEL SEAT

SERIES: YD1
ULTRA LIGHT GUIDE
LEG: MEDIUM
STONE: STAINLESS STEEL (WHITE)
FRAME COLOR: BLACK

COLMIC REEL SEAT

TELESCOPIC POLE

SPENK

XT

SUPER STRONG - ACTION 1

Canna bilanciata e maneggevole, è ideale per la pesca alle grosse prede con elastici anche di grosse dimensioni.

Balanced and handle-able rod, ideal for fishing large prey even with large dimension elastics.

CODE	Length (m)	cl.Length (cm)	Weight (g)	Diameter (mm)	Sect
CASP10A	4,00	100	129	19,70	5
CASP10B	5,00	100	182	20,50	6
CASP10C	6,00	105	245	25,70	7
CASP10D	7,00	110	330	28,60	8



ZOMIT

XT

MEDIUM STRONG - ACTION 2

Affidabile e allo stesso tempo leggera e maneggevole, trova il suo impiego ottimale pescando anche con i terminali più sottili.

Reliable, light and easily maneuverable is perfect for thin hook length and delicate fishing.

CODE	Length (m)	cl.Length (cm)	Weight (g)	Diameter (mm)	Sect
CAZO01A	5,00	130	175	20,40	5
CAZO01B	6,00	130	230	22,80	6
CAZO01C	7,00	130	310	25,20	7
CAZO01D	8,00	130	410	27,70	8
CAZO01E	9,00	130	530	30,40	9



SUPER STRONG
6 m

7,00 m

2018

NEW

COLMIC

19

CANNE \ RODS

www.colmic.it



2018

NEW

COLMIC

20

CANNE \ RODS

www.colmic.it

LIMITED EDITION

XXT

MATCH RODS

SUPERIOR CLASS

Grazie ad uno studio sempre più accurato e l'impiego di materiali di nuova generazione, siamo riusciti ad ottenere una serie di canne altamente performanti, bilanciatissime ed estremamente leggere. Un'evoluzione della serie Real di casa Colmic, che ne eredita e ne esalta tutte le caratteristiche: impugnatura anatomica in sughero, placca porta mulinello con chiusura a scomparsa ed anelli Sea Guide, uniti ad accurate finiture estetiche e funzionali che rendono questi attrezzi un vero gioiello.

Thanks to a more and more careful study and to the use of new generation materials, we have succeeded in obtaining a series of highly performing, extremely balanced and light rods. An evolution of the Real series by Colmic, which inherits and enhances all its features: anatomic cork handle, reel seat with concealed fastening and Sea Guide rings, combined with accurate aesthetic and functional finishes that make these tools a real jewel.



HIGH QUALITY COMPONENTS



SERIES: HL
LEG: LONG
STONE: SIC
FRAME COLOR:
FROSTED GUN SMOKE



SERIES: MHL
LEG: LONG
STONE: SIC
FRAME COLOR:
FROSTED GUN SMOKE



SEA GUIDE DPS REEL SEAT

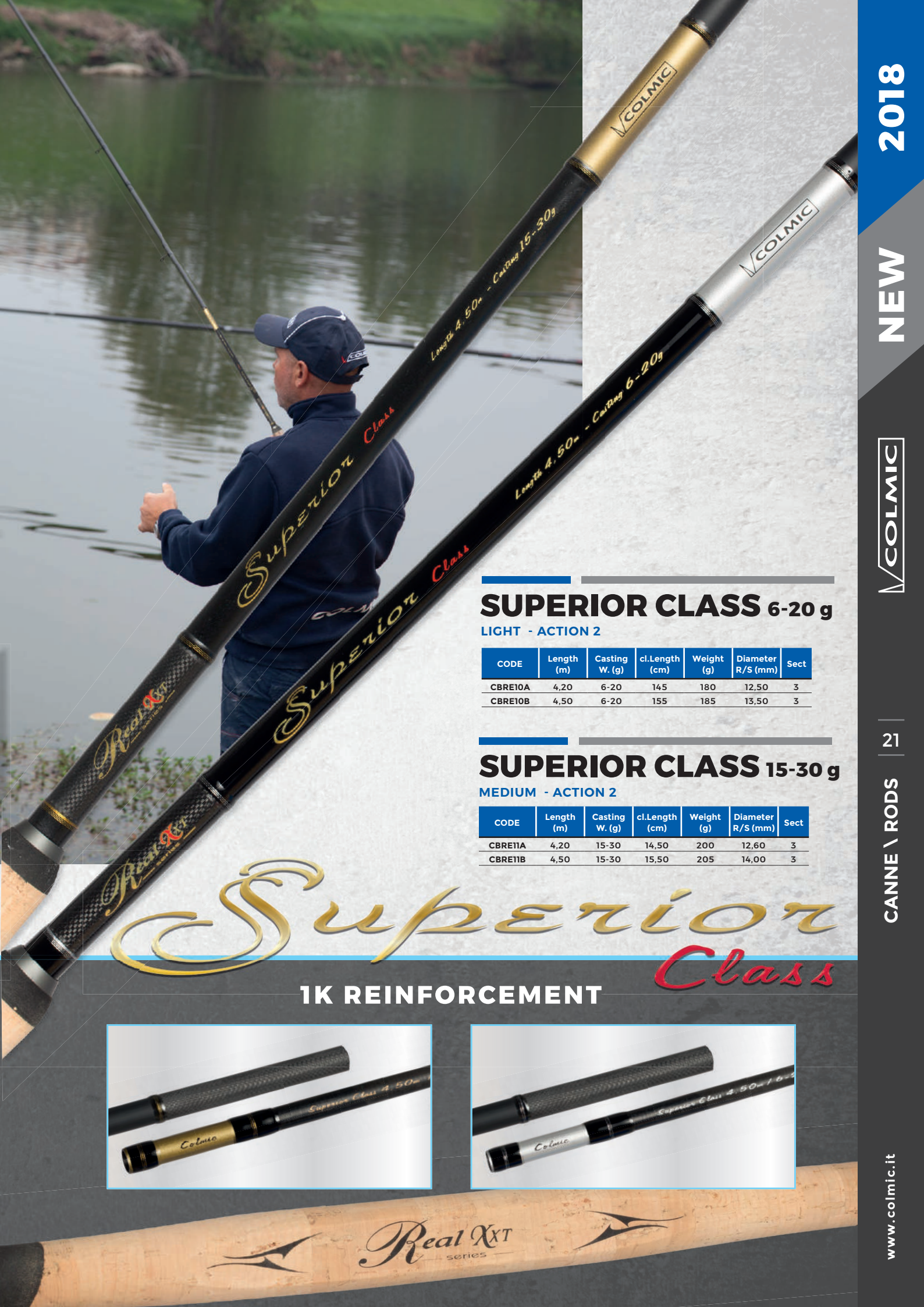

SUPERIOR CLASS 6-20 g
LIGHT - ACTION 2

CODE	Length (m)	Casting W. (g)	cl.Length (cm)	Weight (g)	Diameter R/S (mm)	Sect
CBRE10A	4,20	6-20	145	180	12,50	3
CBRE10B	4,50	6-20	155	185	13,50	3

SUPERIOR CLASS 15-30 g
MEDIUM - ACTION 2

CODE	Length (m)	Casting W. (g)	cl.Length (cm)	Weight (g)	Diameter R/S (mm)	Sect
CBRE11A	4,20	15-30	14,50	200	12,60	3
CBRE11B	4,50	15-30	15,50	205	14,00	3

Superior
Class

1K REINFORCEMENT



MATCH RODS



EXTIMA 6-18 g



LIGHT - ACTION 3

Leggera e maneggevole è ideale per la competizione ad alto livello, per pesche con terminali medio sottili.

Light and maneuverable it's perfect for competition fishing using light to medium hook lengths.

CODE	Length (m)	Casting W. (g)	cl.Length (cm)	Weight (g)	Diameter R/S (mm)	Sect
CBEX01A	4,20	6-18	146	192	12,20	3
CBEX01B	4,50	6-18	156	205	13,30	3



HIGH QUALITY COMPONENTS



SERIES: HL
LEG: LONG
STONE: SIC
FRAME COLOR:
FROSTED GUN SMOKE



SERIES: MHL
LEG: LONG
STONE: SIC
FRAME COLOR:
FROSTED GUN SMOKE



SEA GUIDE DPS REEL SEAT

MATCH RODS

EXTIMA

TOP Level

EXTIMA 10-25 g

XT

MEDIUM - ACTION 2

Leggera e maneggevole è ideale per la competizione, per pesche a medio-lunga distanza con galleggianti fino a 25gr.

Light and maneuverable competition rod, suited for medium to long range fishing with floats up to 25gr.

CODE	Length (m)	Casting W. (g)	cl.Length (cm)	Weight (g)	Diameter R/S (mm)	Sect
CBEX02A	4,20	10-25	146	210	14,00	3
CBEX02B	4,50	10-25	156	215	14,10	3



2018

NEW

COLMIC

23

CANNE \ RODS

www.colmic.it

MATCH RODS

FANNY MATCH XS

MEDIUM - ACTION 2

Canna robusta ed affidabile è particolarmente indicata per la pesca medio pesante.

Strong and reliable particularly indicated for medium heavy fishing.

CODE	Length (m)	Casting W. (g)	cl.Length (cm)	Weight (g)	Diameter R/S (mm)	Sect
CBFA50A	3,90	5-20	137	250	15,80	3
CBFA50B	4,20	5-20	145	310	16,90	3



HIGH QUALITY COMPONENTS



SERIES: MHL
LEG: LONG
STONE: SIMIL SIC
FRAME COLOR: BLACK



SERIES: HL
LEG: LONG
STONE: SIMIL SIC
FRAME COLOR: BLACK



COLMIC DPS REEL SEAT



SILURO - STORIONE

DAGOS

XT

SUPER STRONG - ACTION 1

All-Round per la pesca dei grandi predatori, maneggevole ed equilibrata, ha una potenza di lancio sbalorditiva.

All-Round rod for big predators fishing, very handily and balanced, it has a great power launching.

CODE	Length (m)	Casting W. (g)	cl.Length (cm)	Weight (g)	Diameter R/S (mm)	Sect
CADA10A	4,10	400	166	610	27,10	4



STOR

XT

SUPER STRONG - ACTION 1

Telescopica "a tutto tondo" per la pesca dei grandi predatori, con una potenza di lancio sbalorditiva che, nonostante la sua forza, risulterà molto maneggevole ed equilibrata.

All-Round telescopic rod for big predators fishing with a surprising power launching too, despite of its strength, it will result very handily and balanced.

CODE	Length (m)	Casting W. (g)	cl.Length (cm)	Weight (g)	Diameter R/S (mm)	Sect
CAST70A	4,20	300	157	540	23,90	4



HIGH QUALITY COMPONENTS



SERIES: MN
STONE: SIMIL SIC
FRAME COLOR: BLACK



COLMIC DPS REEL SEAT



SERIES: MN
STONE: SIMIL SIC
FRAME COLOR: BLACK



COLMIC NPS REEL SEAT

400g

300g

BIG FISH



2018

NEW

COLMIC

25

CANNE \ RODS

www.colmic.it

TELE MATCH

TANGO PRO

XXI
SUPER STRONG - ACTION 3

Canna all-round estremamente maneggevole ideale per prede anche di gossa taglia.

All-round rod, strong and maneuverable, suited for heavy duty fishing.

CODE	Length (m)	Casting W. (g)	cl.Length (cm)	Weight (g)	Diameter R/S (mm)	Sect
CATA80A	4,00	30-120	124	320	17,80	4
CATA80B	4,20	30-120	127	330	18,10	4
CATA80C	4,50	30-120	134	364	18,50	4

X-CARBON

REVENGE

XT
STRONG - ACTION 2

Canna dinamica, potente, affidabile e leggera è ideale per la pesca sia in mare che in acqua dolce.

Dynamic rod, powerful, lightweight and reliable, ideal for fishing in the sea and freshwater.

CODE	Length (m)	Casting W. (g)	cl.Length (cm)	Weight (g)	Diameter R/S (mm)	Sect
CARE51A	4,00	10-80	124	249	17,60	4
CARE51B	4,20	10-80	131	265	17,90	4
CARE51C	4,50	10-80	134	283	19,20	5



HIGH QUALITY COMPONENTS



SERIES: YGS
LEG: MEDIUM
STONE: SIMIL SIC
FRAME COLOR: BLACK



COLMIC DPS REEL SEAT



SERIES: OS
LEG: SHORT
STONE: SIMIL SIC
FRAME COLOR: BLACK

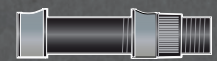

COLMIC DPS REEL SEAT

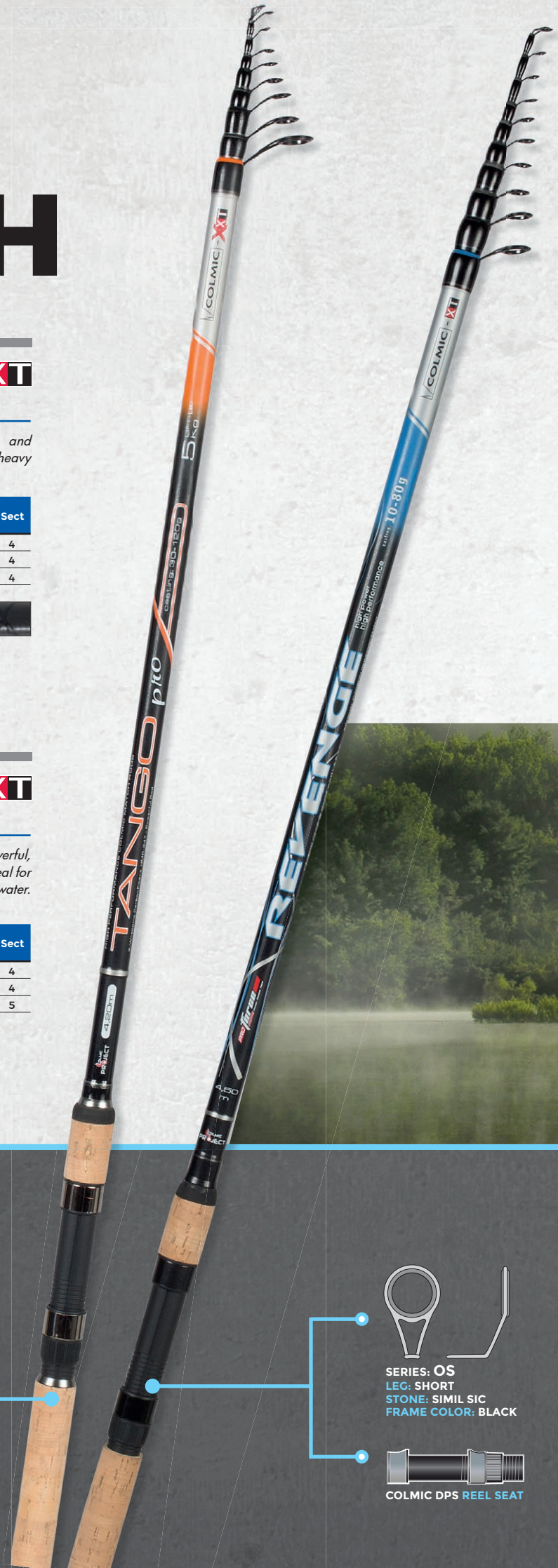

TAIRON

XTI

STRONG - ACTION 2

La versatilità e la solidità della Tairon la rendono indicata per pesche pesanti in mare ed in acqua dolce.

The versatility and stiffness of the Tairon make it suitable for heavy fishing in the sea and in freshwater.

CODE	Length (m)	Casting W. (g)	cl.Length (cm)	Weight (g)	Diameter R/S (mm)	Sect
CATA81A	4,30	10-80	131	228	17,80	4
CATA81B	4,60	10-80	132	245	19,40	5



SALEX

XS

STRONG - ACTION 3

Canna all-round indicata per la pesca in mare e in torrente.

All-round rod, perfect for river or sea fishing.

CODE	Length (m)	Casting W. (g)	cl.Length (cm)	Weight (g)	Diameter R/S (mm)	Sect
CASA81A	4,00	80	132	285	21,60	5
CASA81B	4,20	80	134	353	25,60	3



TELE-MATCH

2018

NEW

COLMIC

27

CANNE \ RODS

www.colmic.it

HIGH QUALITY COMPONENTS



SERIES: OS
LEG: SHORT
STONE: SIMIL SIC
FRAME COLOR: BLACK



COLMIC REEL SEAT



SERIES: OS
LEG: SHORT
STONE: SIMIL SIC
FRAME COLOR: BLACK



COLMIC DPS REEL SEAT

COLMIC SURF CASTING TECHNOLOGY

NEW

COLMIC SURF 3 SECTIONS

1 VETTA SENSITIVE + 1 VETTA TUBOLARE

1 SENSITIVE TIP + 1 TUBULAR TIP

Alcune canne della collezione Surf 2018 sono dotate oltre della normale vetta sensitive, di una vetta interamente tubolare, leggermente più corta, per adeguare la canna ad una pesca in condizioni più gravose. Utilizzando la vetta tubolare la nostra canna risulterà più rigida, così da sfruttare al massimo la sua potenza di lancio specialmente con l'uso di trecciato.

Some Surf 2018 rods collection have more than the normal sensitive tip a tubular one, slightly shorter, to adapt the rod to a more difficult fishing situation. Using the tubular tip our rod will be more rigid to maximize its launch power, especially with the use of braid.

SENSITIVE TIP

TUBULAR TIP

SENSITIVE TIP

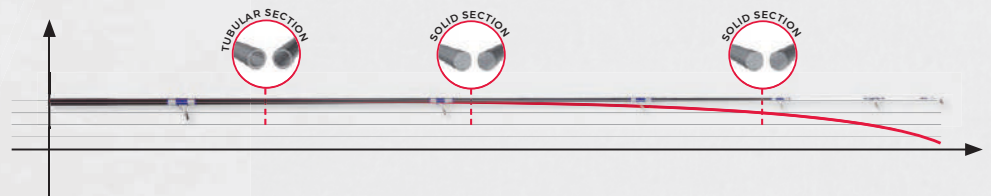

TUBULAR TIP

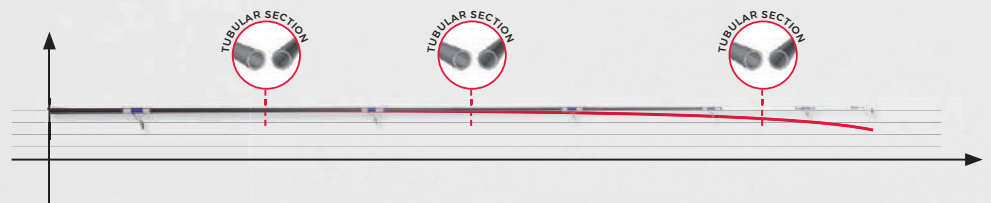

COLMIC HIGH QUALITY COMPONENTS

2018

NEW

COLMIC

29

CANNE \ RODS

www.colmic.it

GUIDES K&NT SERIES

Anelli di ultima generazione studiati appositamente per l'utilizzo di lenze sottili evitando le rotture sugli anelli. La loro forma così aerodinamica ed accattivante, è stata pensata per limitare al massimo i grovigli che il Nylon o il braided sono soggetti a creare durante la loro fuoriuscita ad altissima velocità. In questo modo sarà possibile utilizzare lenze sempre più sottili aumentando la gittata dei lanci.

Guides its a new generation guide expressly developed for thin diameter lines avoiding guides breakage. Its aerodynamic and good looking shape has been to avoid line and braid tangling produced by high line speed. Thanks to this it will be possible to use thinner and thinner lines and performing longer casts.

K
SERIES



NT
SERIES

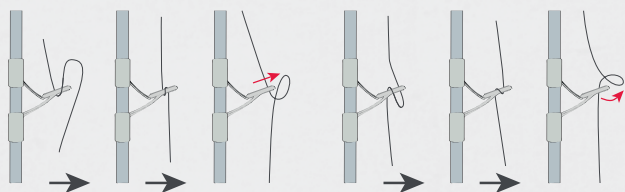

GUIDES LR&MN SERIES

LR
SERIES

MN
SERIES



LUMINOUS PAINT

Speciale vernice fluorescente, che crea dei punti luminosi sulla canna durante la pesca notturna.

Special fluorescent paint, which creates bright spots on the rod during night fishing.



LONG CAST

L'impugnatura è stata disegnata appositamente per una presa ancora più rapida, intuitiva ed ergonomica. Altro elemento importante di questa innovazione, è il perfetto collegamento tra parte verniciata e parte in neoprene senza nessuna variazione di diametro, caratteristica che rende ancor più ottimale la presa in generale.

The grip has been specifically designed for a secure, intuitive and ergonomic handhold. Another important element of this innovation is the perfect link between the painted parts and the neoprene parts without any change to the diameter. This characteristic offers an even more optimal grip in general.



SURF CASTING 3 SECTIONS

ZERO SEVEN SUPERIOR

XXT



Materiali sempre più performanti e tecnologie all'avanguardia fanno di questa canna un "diamante" nel suo genere. Grazie ad un minuziosa progettazione siamo riusciti ad ottenere una canna leggera e potente con una reattività in fase di lancio di circa 25% superiore delle sue competitor. Ideale sia per il ground che per il pendolare, La ZeroSeven Superior è la canna di ogni professionista.

Advanced materials and up-to-date technologies make this rod a "diamond" of its category. Thanks to a detailed project we managed to get a light and powerful rod with a 25% higher reactivity during the launch phase. Ideal for both ground and commuter, ZeroSeven Superior is the perfect rod for any professional angler.



ZERO 07 S

HIGH QUALITY COMPONENTS

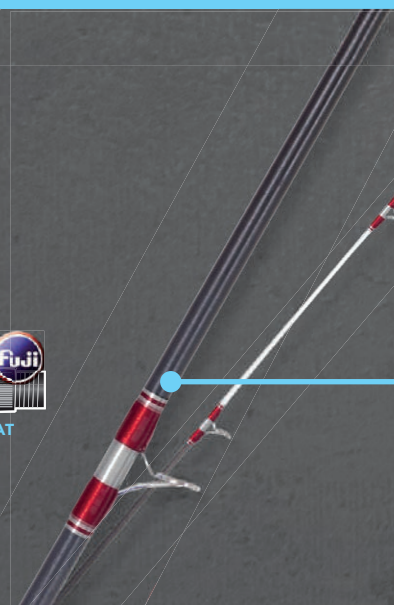
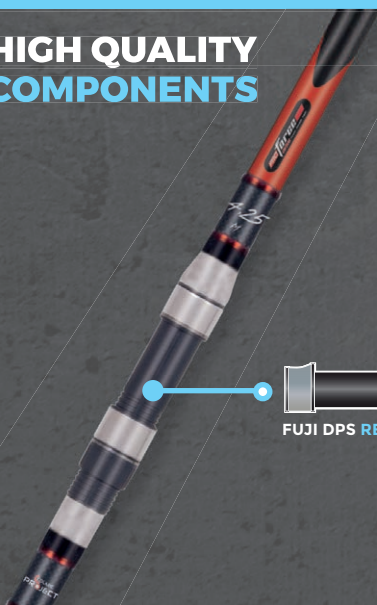

SERIES: KW
LEG: TANGOL FREE
STONE: ALCONITE
FRAME COLOR: FROSTED WHITE

SURF CASTING 3 SECTIONS



NO TUBULAR TIP

07-SUPERIOR 80-200 g

MEDIUM STRONG - ACTION 1

CODE	TIP	Length (m)	Casting W. (g)	Optimum Performance	Lift-Up (Kg)	cl.Length (cm)	Weight (g)	Diameter R/S (mm)
CAZE46C	Sensitive	4,25	80-200	150g	4,5	153	390	19,90
CAZE46D	Sensitive	4,50	80-200	150g	3,5	160	415	20,10

TUBULAR TIP INCLUDED

07-SUPERIOR 100-250 g

STRONG - ACTION 1

CODE	TIP	Length (m)	Casting W. (g)	Optimum Performance	Lift-Up (Kg)	cl.Length (cm)	Weight (g)	Diameter R/S (mm)
CAZE46A	Sensitive	4,30	100-250	180g	3,5	153	405	20,90
	Tubular	4,05		250g				
CAZE46B	Sensitive	4,60	100-250	180g	3,5	163	505	21,70
	Tubular	4,30		250g				

SEVEN SUPERIOR

HIGH QUALITY

2018

NEW

COLMIC

31

CANNE \ RODS

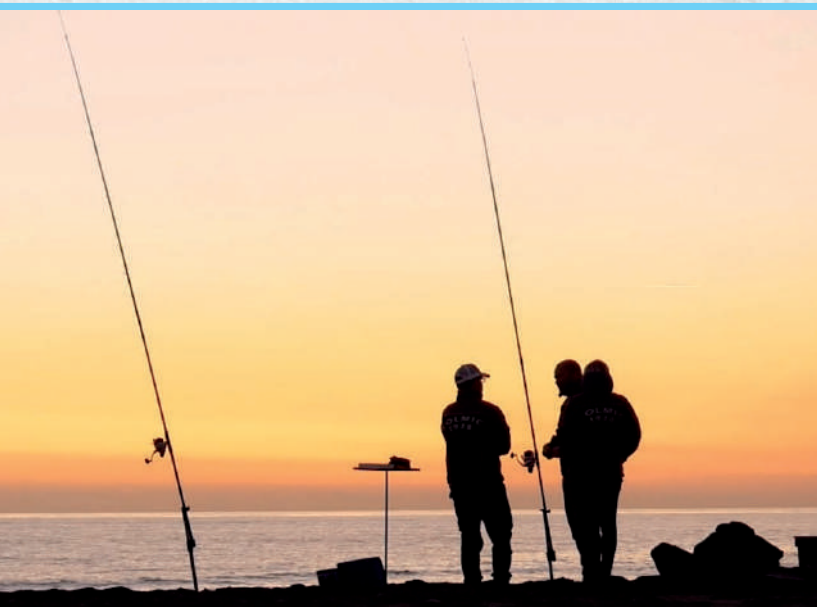

EXTRA TIPS ZERO SEVEN FI

4,30m 100/250g - Code: CAZE43A2

4,60m 100/250g - Code: CAZE43B2

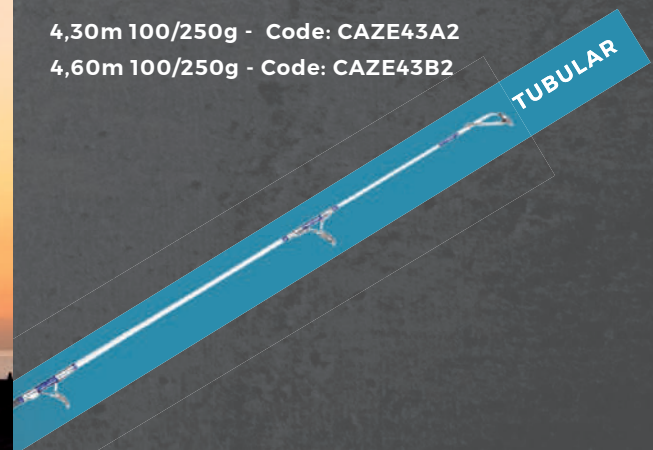

SURF CASTING 3 SECTIONS

SUPERBA NX

MEDIUM STRONG - ACTION 2



Canna realmente semplice da gestire, ma con tutte le caratteristiche di un prodotto di fascia più elevata. Progettata su diametri ridotti i, è leggera, bilanciatissima, sensibile in pesca e si carica benissimo anche con un side cast normalmente eseguito.

The rod is really simple to manage, bearing all the features expected from a higher end product. Rod designed on really small base diameters. It is light, extremely balanced, sensible during fishing and loads very well even with a normal side cast.

CODE	TIP	Length (m)	Casting W. (g)	Optimum Performance	Lift-Up (Kg)	cl.Length (cm)	Weight (g)	Diameter R/S (mm)
CASU90A	Sensitive	4,20	100-250	170g	4	156	425	19,50
	Tubular	4,05		200g				
CASU90B	Sensitive	4,50	100-250	150g	4	166	440	21,15
	Tubular	4,30		180g				



HIGH QUALITY COMPONENTS



SERIES: KW
LEG: TANGOL FREE
STONE: ALCONITE
FRAME COLOR: WHITE CROME



FUJI DPS REEL SEAT



SURF CASTING 3 SECTIONS



IMPERIAL PRO

MEDIUM STRONG - ACTION 2



L'Imperial Pro progettata su diametri sottili risulta essere leggera, bilanciata e con un'ottima sensibilità in pesca. Ideale per un side cast normalmente eseguito è un ottimo compromesso tra prestazioni e semplicità.

The Imperial Pro designed on small diameters, is light, balanced and with an excellent sensitivity while fishing. Ideal for normally executed side casting, it is an excellent compromise between performance and simplicity.

CODE	TIP	Length (m)	Casting W. (g)	Optimum Performance	Lift-Up (Kg)	cl.Length (cm)	Weight (g)	Diameter R/S (mm)
CAIM100A	Sensitive	4,20	100-250	170g	4	156	425	19,50
	Tubular	4,05		200g				
CAIM100B	Sensitive	4,50	100-250	150g	4	166	440	21,15
	Tubular	4,30		180g				



HIGH QUALITY COMPONENTS



SERIES: BDG-1
ULTRA LIGHT GUIDE
 STONE: STAINLESS STEEL
 FRAME COLOR: BLACK



COLMIC DPS REEL SEAT



2018

NEW



33

CANNE \ RODS

www.colmic.it

SURF CASTING 3 SECTIONS



GARDIAN

XT
(80-200g): MEDIUM STRONG - ACTION 2
(100-250g): STRONG - ACTION 2

Canna leggera, affidabile, bilanciata è progettata per i professionisti, ma grazie alla sua maneggevolezza è ideale anche per il semplice pescatore, che vuole una canna ad alte prestazioni, facile da utilizzare in fase di lancio.

Light rod, reliable, balanced and designed for professionals, but thanks to its handling, it is also ideal for the ordinary fisherman who wants a high-performance rod which is easy to use in the casting phase.

CODE	TIP	Length (m)	Casting W. (g)	Optimum Performance	Lift-Up (Kg)	cl.Length (cm)	Weight (g)	Diameter R/S (mm)
CAGA102A	Sensitive	4,20	80-200	150g	3,5	143	410	20,90
	Tubular	4,00		200g				
CAGA102B	Sensitive	4,20	100-250	170g	3,5	145	440	21,40
	Tubular	4,00		225g				

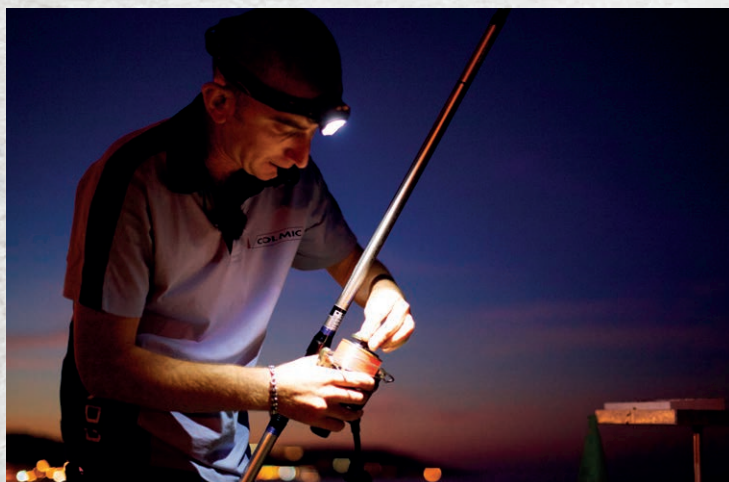

HIGH QUALITY COMPONENTS



SERIES: XQ
LEG: MEDIUM
STONE: SIC
FRAME COLOR: WHITE CROME



COLMIC DPS REEL SEAT

SURF CASTING 3 SECTIONS

2018

NEW

COLMIC

35

CANNE \ RODS

www.colmic.it

ETAN X3

(80-200g): MEDIUM STRONG - ACTION 2
(100-250g): STRONG - ACTION 2



XT

Alte prestazioni e facilità di utilizzo sono le caratteristiche che contraddistinguono questa canna. Leggera, bilanciata e affidabile è stata studiata per tutti i pescatori, dall'esperto al meno esperto.

High performance and easy to use, are the characteristics which distinguish this rod. Light, balanced and reliable, it has been designed for fishermen, from the expert to the aspiring expert.

CODE	TIP	Length (m)	Casting W. (g)	Optimum Performance	Lift-Up (Kg)	cl.Length (cm)	Weight (g)	Diameter R/S (mm)
CAET30A	Sensitive	4,20	80-200	150g	3,5	3,5	143	410
	Tubular	4,00		200g				
CAET30B	Sensitive	4,20	100-250	170g	3,5	3,5	145	440
	Tubular	4,00		225g				



MAJEST

(80-200g): MEDIUM STRONG - ACTION 2
(100-250g): STRONG - ACTION 2



XT

Leggera, affidabile, bilanciata è stata realizzata per tutti i pescatori, dall'esperto al meno esperto. Un ottimo compromesso tra prestazioni e semplicità di utilizzo, in tutte le fasi di pesca.

Leggera, affidabile, bilanciata è stata realizzata per tutti i pescatori, dall'esperto al meno esperto. Un ottimo compromesso tra prestazioni e semplicità di utilizzo, in tutte le fasi di pesca.

CODE	Length (m)	Casting W. (g)	Optimum Performance	Lift-Up (Kg)	cl.Length (cm)	Weight (g)	Diameter R/S (mm)
CAMA95A	4,20	80-200	150g	3,5	143	410	20,90
CAMA95B	4,20	100-250	160g	3,5	145	440	21,40



HIGH QUALITY COMPONENTS



SERIES: CR
STONE: SIMIL SIC
FRAME COLOR: BLACK



SURF CASTING

3 SECTIONS

FENOX SURF

STRONG - ACTION 2

La Fenox leggera e facile da utilizzare riesce a far collimare perfettamente doti di potenza con quelle di estrema maneggevolezza.

The light and easy-to-use Fenox perfectly combines power with extreme handling capabilities.

CODE	Length (m)	Casting W. (g)	Optimum Performance	Lift-Up (Kg)	cl.Length (cm)	Weight (g)	Diameter R/S (mm)
CAFE01A	4,20	100-250	160g	5	149	490	23,10
CAFE01B	4,50	100-250	160g	5	159	570	23,20



LAIRA SURF

STRONG - ACTION 2

Potente e molto versatile, può essere utilizzata nei più svariati frangenti di pesca, dalla spiaggia o dalla roccia. Sensibile in pesca e potente nel lancio, questa canna saprà regalarvi momenti di puro divertimento. Adatta anche alla pesca con il vivo e per la cosiddetta tecnica a "teleferica".

The rod is very powerful and versatile rod, can be used in multiple fishing situations, from the beach or from the rocks, sensible during the fishing action and powerful during the casting. Suitable for live bait fishing in the "cableway" technique.

CODE	Length (m)	Casting W. (g)	Optimum Performance	Lift-Up (Kg)	cl.Length (cm)	Weight (g)	Diameter R/S (mm)
CALA02A	4,20	100-200	150g	5	149	5,30	23,10
CALA02B	4,50	100-200	150g	5	159	560	23,20



HIGH QUALITY COMPONENTS



SERIES: K
LEG: NO TANGLE
STONE: SIMIL SIC
FRAME COLOR: BLACK



SERIES: LR
STONE: SIMIL SIC
FRAME COLOR: BLACK



COLMIC DPS REEL SEAT



COLMIC DPS REEL SEAT



SURF CASTING 2 SECTIONS



DUKESSA

XT

SUPER STRONG - ACTION 1

Canna in 2 pezzi per la pesca surf casting. Sottile, affidabile e molto potente è perfetta per le competizioni di lancio tecnico.

Rod in two pieces for surf casting. Thin, reliable and very powerful, it is perfect for technical casting.

CODE	Length (m)	Casting W. (g)	cl.Length (cm)	Weight (g)	Diameter R/S (mm)	Sect
CADU20A	4,15	100-300	210	635	21,6	2



AMTEA SURF

XT

SUPER STRONG - ACTION 1

Canna in 2 pezzi per la pesca surf casting. Affidabile, reattiva e molto potente è perfetta per lanci potenti come ground e pendolare e per le competizioni di lancio tecnico.

Rod in two pieces for surf casting. Reliable, reactive and very powerful, perfect for powerful casting such as ground and pendulum casting and for technical casting competitions.

CODE	Length (m)	Casting W. (g)	cl.Length (cm)	Weight (g)	Diameter R/S (mm)	Sect
CAAM70A	4,10	100-300	210	690	25,50	2



HIGH QUALITY COMPONENTS

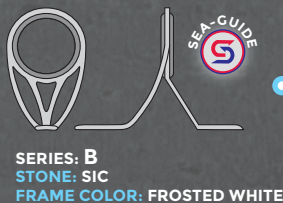

2018

NEW

COLMIC

37

CANNE \ RODS

www.colmic.it

TELESURF

LITUAR

XT

ACTION 2

Canne dotate di cimino in carbonio pieno, affidabili, leggere e performanti, si adattano perfettamente al lancio in over head e side casting, permettendo anche al pescatore meno esperto di raggiungere distanze di tutto rispetto.

Rod series featuring a solid full carbon tip. The rods are reliable, light and performing. They are really simple to manage and perfectly suitable for both overhead and side casting. They allow even the less experienced anglers to reach long distances.

CODE	Length (m)	Casting W. (g)	cl.Length (cm)	Weight (g)	Diameter R/S (mm)	Sect
CAL150A	4,20	60-120	155	370	20	6
CAL150B	4,20	80-160	155	390	20	6



SCOGLIERA

bombarda
XT

ACTION 2

Canna telescopica nata per la pesca a recupero con le bombarde dalla spiaggia. Leggera, bilanciata e molto maneggevole è perfetta anche per la pesca a surf-casting leggero.

Telescopic rod born for recovery fishing with sinkers, from the beach. Light, balanced and very manoeuvrable, it is also perfect for light surf casting.

CODE	Length (m)	Casting W. (g)	cl.Length (cm)	Weight (g)	Diameter R/S (mm)	Sect
CASC02A	3,90	20-100	125	420	22,80	5



HIGH QUALITY COMPONENTS



SERIES: BDG-1
ULTRA LIGHT GUIDE
 STONE: SIC
 FRAME COLOR: BLACK



COLMIC NPS REEL SEAT



SERIES: MN
 STONE: SIMIL SIC
 FRAME COLOR: BLACK



COLMIC DPS REEL SEAT



HELAND

XS

ACTION 2

Affidabili, leggere e performanti. Molto semplici da gestire, si adattano perfettamente al lancio in over head e side casting, permettendo anche al pescatore meno esperto di raggiungere distanze di tutto rispetto.

The rods are reliable, light and performing. They are really simple to manage and perfectly suitable for both overhead and side casting. They allow even the less experienced anglers to reach long distances.

CODE	Length (m)	Casting W. (g)	cl.Length (cm)	Weight (g)	Diameter R/S (mm)	Sect
CAHES0A	4,20	120	150	400	22,00	6
CAHES0B	4,20	150	150	403	22,00	6
CAHES0C	4,20	180	150	426	22,10	6
CAHES0D	4,50	150	150	470	22,80	6
CAHES0E	4,50	180	150	488	23,54	6



SHAPT

XS

ACTION 1

Telescopica per la pesca a surf casting. E' molto potente, affidabile ed ha un rapporto qualità prezzo molto vantaggioso.

A telescopic rod for surf casting. The unit offers excellent power and reliability, as well as an extremely advantageous quality-price ratio.

CODE	Length (m)	Casting W. (g)	cl.Length (cm)	Weight (g)	Diameter R/S (mm)	Sect
CASH01C	3,90	250	122	400	22,30	4
CASH01D	4,20	250	152	490	22,50	4



HIGH QUALITY COMPONENTS



WEBO GUIDES

SERIES: MN
STONE: SIMIL SIC
FRAME COLOR: BLACK



COLMIC DPS REEL SEAT



SERIES: MN
STONE: SIMIL SIC
FRAME COLOR: BLACK



COLMIC NPS REEL SEAT

2018

NEW

COLMIC

39

CANNE \ RODS

www.colmic.it

TELESURF GLUE GUIDE

FABULA

XT

ACTION 1

Telescopica da surf casting pratica, affidabile, bilanciata e semplicissima da utilizzare; viene proposta 2 misure con 200g di potenza. Ottimo rapporto qualità prezzo.

A telescopic rod practical, reliable, well balanced and easy to use rod; it comes in two sizes with power 200g. Outstanding quality price ratio.

CODE	Length (m)	Casting W. (g)	cl.Length (cm)	Weight (g)	Diameter R/S (mm)	Sect
CAFA50A	4,20	200	128	425	23,50	4
CAFA50B	4,50	200	128	439	23,50	4



ELLIS

XS

ACTION 1

Canna tele-surf, strutturata in maniera tale da garantire affidabilità ed ottime performance. Valida per qualunque tipo di pesca dalla spiaggia e per il rock fishing light.

Surf casting rod, especially developed to guarantee reliability and great performances. Also suitable for any kind of beach fishing as well as for rock fishing.

CODE	Length (m)	Casting W. (g)	cl.Length (cm)	Weight (g)	Diameter R/S (mm)	Sect
CAEL20A	4,20	100-300	135	570	24,90	4



SCAD

XS

ACTION 1

Telescopica per la pesca a surf casting. E' molto potente, affidabile ed ha un rapporto qualità prezzo molto vantaggioso.

A telescopic rod for surf casting. The unit offers excellent power and reliability, as well as an extremely advantageous quality-price ratio.

CODE	Length (m)	Casting W. (g)	cl.Length (cm)	Weight (g)	Diameter R/S (mm)	Sect
CASCO1A	4,20	200	125	605	27,30	4



HIGH QUALITY COMPONENTS

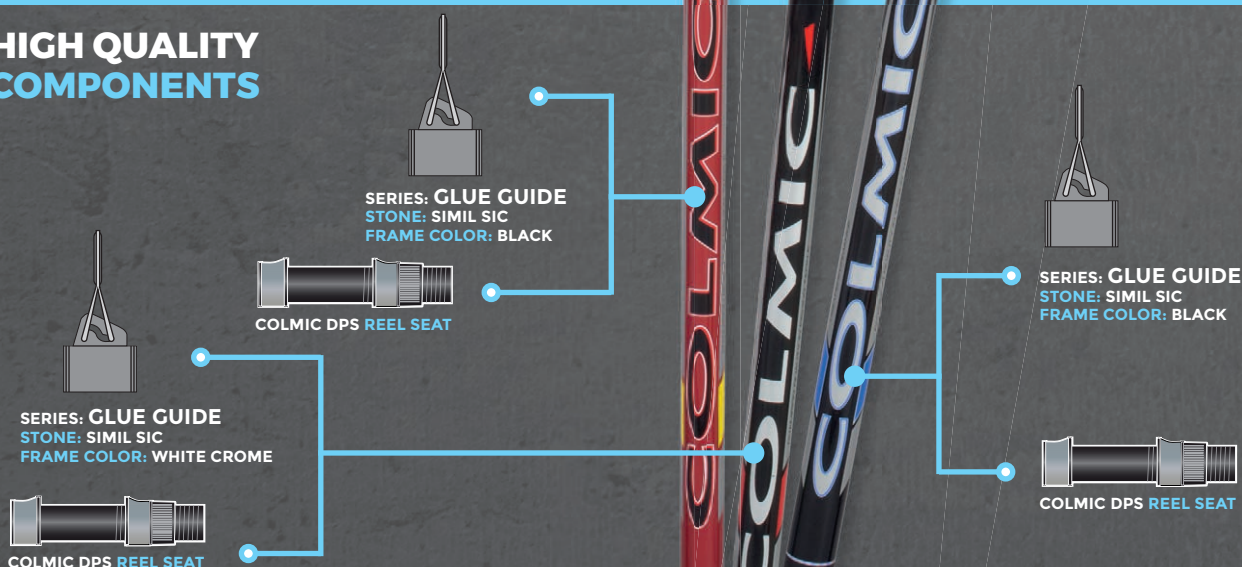

TELE BEACH

HIGH COMPETITION

VIRGON



LIGHT - ACTION 3

Telescopica da Beatc Ledgering pratica, affidabile, bilanciata e semplicissima da utilizzare; Ottimo rapporto qualità prezzo.

A telescopic rod practical, reliable, well balanced and easy to use rod. Outstanding quality price ratio.

CODE	Length (m)	Casting W. (g)	cl.Length (cm)	Weight (g)	Diameter R/S (mm)	Sect
CAVI52A	5,00	30-100	144	327	22,10	6+tips



SUPER SENSITIVE TIPS

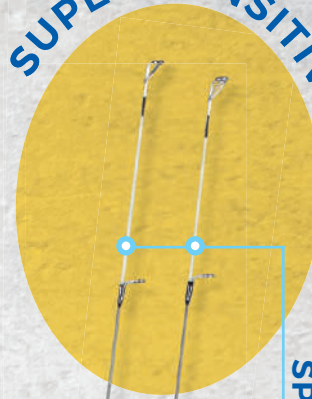

SPECIAL FLUORESCENT TIPS

CARBON TIP 40-100g

CARBON TIP 30-50g

HIGH QUALITY COMPONENTS



SERIES: T
LEG: MEDIUM
STONE: SIC
FRAME COLOR: FROSTED WHITE



FUJI REEL SEAT



SERIES: OS
LEG: SHORT
STONE: SIC
FRAME COLOR: FROSTE WHITE

2018

NEW



47

CANNE \ RODS

www.colmic.it

TELE BEACH

ZENCA

XT

ACTION 2

Telescopica prodotta in carbonio alta resistenza progettata per la pesca a beach-ledgering. Ha un fusto rigido ed una vetta molto sensibile prodotta in carbonio pieno.

A telescopic rod made from high-strength carbon, designed for beach ledgering. The unit has a rigid shaft and an extremely sensitive full-carbon tip.

CODE	Length (m)	Casting W. (g)	cl.Length (cm)	Weight (g)	5Diameter R/S (mm)	Sect
CAZE50B	4,20	30-100	148	310	18,80	5



KXR

XS

ACTION 3

Questa telescopica da beach a pezzatura corta, è costruita con ottimi materiali e risulta quindi molto pronta e reattiva. Una canna divertente, leggera e maneggevole. Ottimo rapporto qualità prezzo.

This new telescopic beach ledgering rods have been built using great materials, resulting very reactive. A very handy, light and enjoyable object. Not to forget also its remarkable quality price ratio.

CODE	Length (m)	Casting W. (g)	cl.Length (cm)	Weight (g)	Diameter R/S (mm)	Sect
CAKXR01A	4,10	30-100	125	348	19,30	5
CAKXR01B	4,10	50-120	125	362	19,70	5



HIGH QUALITY COMPONENTS

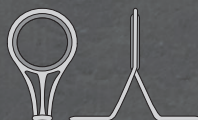

SERIES: T
LEG: MEDIUM
STONE: SIMIL SIC
FRAME COLOR: BLACK



SERIES: OS
LEG: SHORT
STONE: SIMIL SIC
FRAME COLOR: BLACK



SERIES: T
LEG: MEDIUM
STONE: SIMIL SIC
FRAME COLOR: BLACK



SERIES: OS
LEG: SHORT
STONE: SIMIL SIC
FRAME COLOR: BLACK



COLMIC NPS REEL SEAT



COLMIC NPS REEL SEAT



SPECIAL BOAT

VENOS

XXT

STRONG - ACTION 2

Canna da bolentino in 3 sezioni più mini prolunga, potente, robusta e affidabile. Grazie alla particolare struttura in carbonio e alle tre vette intercambiabili è adatta sia alla pesca con grammature leggere che con zavorre più pesanti.

Ground angling rod in 3 sections plus mini extension, powerful, robust and reliable. Thanks to the particular structure in carbon and to the three interchangeable tips, it is adapted to fishing with both lighter weights, and with heavier sinkers.

CODE	Length (m)	Casting W. (g)	cl.Length (cm)	Weight (g)	Diameter R/S (mm)	Sect
CAVE35A	3,30-3,80	30-200	110	300	14,90	4+3TIP



CARBON TIP HH - 550mm

CARBON TIP MH - 600mm

CARBON TIP LH - 650mm



HIGH QUALITY COMPONENTS



SERIES: XM
LEG: MICRO GUIDES
STONE: SIC
FRAME COLOR: FROSTED WHITE



SERIES: XB
STONE: SIC
FRAME COLOR: FROSTED WHITE



DPS REEL SEAT



MINI EXTENSION

2018

NEW

COLMIC

43

CANNE \ RODS

www.colmic.it

BOAT 2 SECTIONS

SPECIAL
SQUID

KITA KAREI *Dasku* **XXT**

MEDIUM - ACTION 3

Canna ideata per la pesca dalla barca con Misaki, Sabiki e Inchiku, sensibile con una grande riserva di potenza è adatta alla pesca di sgombri, sugarelli, con i Sabiki e calamari con i Misaki.

Rod designed for fishing from boat with Misaki, Sabiki and Inchiku has been designed to be more reliable. Sensitive and powerful rod suitable for fishing of mackerel, jack mackerel with Sabiki and squid with Misaki.

CODE	Length (ft)	Casting W. (g)	cl.Length (cm)	Weight (g)	Diameter R/S (mm)	Sect
CAK180A	7'2"	160	110	120	10,40	2
CAK180B	8'2"	160	125	130	11,00	2
CAK180C	9'2"	160	143	165	11,90	2



PVC GIMBAL



KUNA SPECIAL BOLENTINO **XT**

MEDIUM STRONG - ACTION 3

Canna da boletino medio leggero, prodotta in carbonio HMC40 T, viene corredata di vetta con azione sensibile e colorata con vernice fluorescente.

Rod for medium-light boat fishing from boat. Made from HMC40 T carbon, it is equipped with sensitive action tip coated with fluorescent paint.

CODE	Length (m)	Casting W. (g)	cl.Length (cm)	Weight (g)	Diameter R/S (mm)	Sect
CAKU01A	1,80	20-150	94	110	8,60	2
CAKU01B	2,10	20-150	112	125	10,10	2
CAKU01C	2,40	20-150	126	160	11,10	2
CAKU01D	2,70	20-150	141	180	11,60	2



HIGH QUALITY COMPONENTS



SERIES: MK
LEG: MICRO GUIDES
STONE: SIMIL SIC
FRAME COLOR: BLACK



SERIES: MK
LEG: MICRO GUIDES
STONE: SIMIL SIC
FRAME COLOR: BLACK



SERIES: OS
LEG: SHORT
STONE: SIMIL SIC
FRAME COLOR: BLACK



SERIES: XB
STONE: SIMIL SIC
FRAME COLOR: BLACK



BOAT 2 SECTIONS

MARLET

XT

STRONG - ACTION 2

Canna ideale per ogni tipo di pesca dalla barca. Leggera, bilanciata e potentissima, sviluppa un'azione rigida ed una buona sensibilità alla vetta.

Rod ideal for every type of boat fishing; light and balanced, it develops a stiff action with good sensitivity at the tip.

CODE	Length (m)	Casting W. (g)	cl.Length (cm)	Weight (g)	Diameter R/S (mm)	Sect
CAMA96A	2,10	70-300	109	250	12,90	2
CAMA96B	2,40	70-300	125	273	14,30	2
CAMA96C	2,70	70-300	140	292	15,80	2
CAMA96D	3,00	70-300	156	315	16,50	2

PVC GIMBAL

ULTRA LIGHT BLENDS PRICE FIBER

STERN PRO

XS

STRONG - ACTION 2

Canna da bolentino medio pesante. Il suo rapporto qualità prezzo è ottimo e le finiture altrettanto.

Rod for medium-heavy boat fishing from boat. The price-quality ratio is excellent, as are the finishes.

CODE	Length (m)	Casting W. (g)	cl.Length (cm)	Weight (g)	Diameter R/S (mm)	Sect
CAST80A	2,10	200	110	219	18,00	2
CAST80B	2,40	200	124	278	19,30	2
CAST80C	2,70	200	138	323	19,60	2

HIGH QUALITY COMPONENTS



SERIES: XB
STONE: SIMIL SIC
FRAME COLOR: BLACK



COLMIC DPS REEL SEAT

SERIES: XM
LEG: MICRO GUIDES
STONE: SIMIL SIC
FRAME COLOR: BLACK



SERIES: MN-OB
STONE: SIMIL SIC
FRAME COLOR: BLACK



COLMIC DPS REEL SEAT

2018

NEW

COLMIC

45

CANNE \ RODS

www.colmic.it

TELE ADJUSTABLES



XXT

SEA LION SUPERIOR

(40-200g) MEDIUM STRONG - ACTION 2

(70-300g) STRONG - ACTION 2

Canna da bolettino, leggera e bilanciata ideale per profondità medie con grammature pesanti.

Rod for boat fishing, light and balanced, ideal for medium deep and heavy weight.

CODE	Length (m)	Casting W. (g)	cl.Length (cm)	Weight (g)	Diameter R/S (mm)	Sect
CASEA20A	3,20-4,00	40-200	141	220	18,80	4+3tips
CASEA20B	3,20-4,00	70-300	141	210	18,80	4+3tips



CARBON TIP - ACTION H

CARBON TIP - ACTION M

CARBON TIP - ACTION L

HIGH QUALITY COMPONENTS



SERIES: L
LEG: MICRO GUIDES
STONE: ALCONITE
FRAME COLOR: SILVER WHITE



SERIES: MN
STONE: ALCONITE
FRAME COLOR: SILVER WHITE

TELE ADJUSTABLES

2018

NEW

COLMIC

47

CANNE \ RODS

www.colmic.it

KAM ORATA



MEDIUM - ACTION 3

Canna da bolentino teleregolabile, leggera e affidabile ha un ingombro contenuto e un'azione sensibile per la pesca dei pesci "difficili", come orate e fragolino.

Tele-adjustable ground angling rod, light and reliable, it has a contained bulk and a sensitive action for fishing "difficult" fish, such as sea or red bream.

CODE	Length (m)	Casting W. (g)	cl.Length (cm)	Weight (g)	Diameter R/S (mm)	Sect
CAKA61A	3,30-3,80	30-200	95	210	18,60	7



TOP LIVE



MH - ACTION 2 / HH ACTION 3

Telescopiaca a pezzatura corta, affidabile e versatile è ideale sia per la pesca a bolentino medio-pesante, che per la pesca dalla barca con Misaki, Sabiki e Inchiku.

Short, reliable and versatile telescopic rod ideal for medium to heavy trolling, as well as for boat fishing with Misaki, Sabiki and Inchiku.

CODE	Length (m)	ACTION	cl.Length (cm)	Weight (g)	Diameter R/S (mm)	Sect
CATO10A	2,50-2,90	MH	90	200	16,50	6
CATO10B	2,70-3,20	ML	90	190	16,50	6

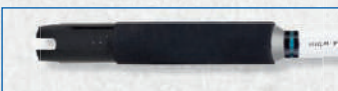

HIGH QUALITY COMPONENTS



SERIES: XM
LEG: MICRO GUIDES
STONE: SIC
FRAME COLOR: FROSTED WHITE



SERIES: XY
LEG: SHORT
STONE: SIC
FRAME COLOR: FROSTED WHITE



FUJI REEL SEAT



SERIES: XT
LEG: MEDIUM
STONE: SIMIL SIC
FRAME COLOR: BLACK



SERIES: OS
LEG: SHORT
STONE: SIMIL SIC
FRAME COLOR: BLACK



COLMIC NPS REEL SEAT

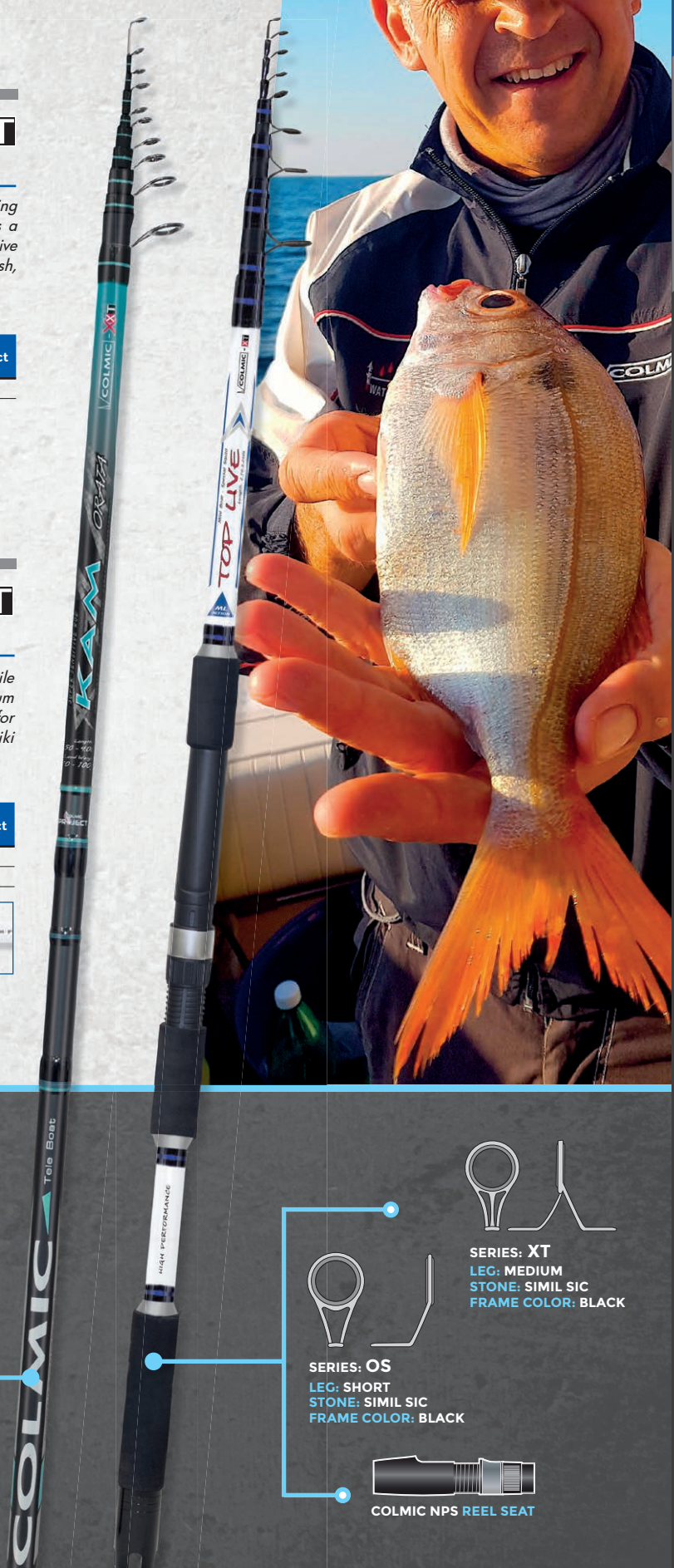

TELE - BOAT SPECIAL SQUID



KORAL SQUID XT

MEDIUM - ACTION 3

Canna da barca telescopica, leggera e affidabile ha una straordinaria sensibilità di vetta per la pesca ai calamari e ai totani.

Telescopic boat rod, light and reliable, it has extraordinary sensitivity of the tip for fishing squid and cuttlefish.

CODE	Length (m)	Casting W. (g)	cl.Length (cm)	Weight (g)	Diameter R/S (mm)	Sect
CAK010A	3,00	100	104	105	17	4



SQUIDAR XT

MEDIUM - ACTION 2

Canna da barca telescopica, leggera e dall'ingombro contenuto è ideale per la pesca a SQUID.

Telescopic boat rod, light with contained bulk, it is ideal for fishing for SQUID.

CODE	Length (m)	Casting W. (g)	cl.Length (cm)	Weight (g)	Diameter R/S (mm)	Sect
CASQ01A	2,50	30-120	104	190	14,9	4



HIGH QUALITY COMPONENTS

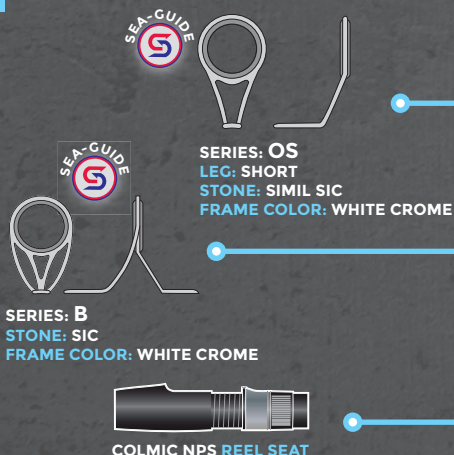

TELE - BOAT SPECIAL ORATA

PAMIR BOAT

XTI

STRONG - ACTION 2

Canna telescopica in carbonio, sottile, potente e dall'ingombro ridotto ha un'azione particolarmente sensibile in vetta.

Telescopic rod in carbon, thin, potent and with reduced bulk, it has a particularly sensitive action at the tip.

CODE	Length (m)	Casting W. (g)	cl.Length (cm)	Weight (g)	Diameter R/S (mm)	Sect
CAPA81A	2,10	50-200	100	145	13,10	3
CAPA81B	2,50	50-200	104	200	16,40	4
CAPA81C	3,00	50-200	110	270	19,60	5



MULTI COLOUR TIPS

MAKAR SPECIAL ORATA

XTI

MEDIUM - ACTION 3

Canna da bolentino teleregolabile, leggera, robusta e affidabile ha un ingombro contenuto e un'azione sensibile.

Tele-adjustable ground angling rod, light, robust and reliable, it has a contained bulk and a sensitive action.

CODE	Length (m)	Casting W. (g)	cl.Length (cm)	Weight (g)	Diameter R/S (mm)	Sect
CAMA01A	3,80	20-80	63	170	18,10	8



MULTI COLOUR TIPS



HIGH QUALITY COMPONENTS



SERIES: T
LEG: MEDIUM
STONE: SIMIL SIC
FRAME COLOR: BLACK



SERIES: OS
LEG: SHORT
STONE: SIMIL SIC
FRAME COLOR: BLACK



COLMIC REEL SEAT



COLMIC DPS REEL SEAT



SERIES: OS
LEG: SHORT
STONE: SIMIL SIC
FRAME COLOR: BLACK

SERIES: MK
LEG: MICRO GUIDES
STONE: SIMIL SIC
FRAME COLOR: BLACK



2018

NEW

COLMIC

49

CANNE \ RODS

www.colmic.it

ARGENTIA

XXT

ACTION 4

Canna indicata per il Big Game fishing. Non solo pesca in drifting al tonno ma anche traina d'altura. Gli anelli roller Stuart permettono di utilizzare monofilo di qualsiasi diametro.

Rod dedicated to the "Big Game" fishing. It not only fishes Tuna in drifting, but also during throws in deep waters. The Roller Stuart guides permit to use any diameter monofilament.

CODE	Length (m)	Casting W. (lb)	cl.Length (cm)	Weight (g)	Diameter R/S (mm)	Sect
CDAR01	5'6"	50-80	127	785	13,20	1+U.B.
CDAR02	5'6"	80-120	127	1000	15,70	1+U.B.
CDAR03	6'	30-50	138	820	14,80	1+U.B.
CDAR04	6"	50-80	138	930	16,90	1+U.B.



ONEWAY

XXT

ACTION 3

Il futuro è utilizzare il "Braided Line" in bobina. Ecco perché Colmic ha progettato una canna potente con anelli Fuji SIN-II. Oneway sarà sicuramente uno "status symbol" del Angler moderno.

The future in fishing is to use the spooled "Braided Line". This is the reason why Colmic has designed a powerful rod with Fuji SIN-II guides. "Oneway" will certainly become a "status symbol" for the modern Angler.

CODE	Length (m)	Casting W. (lb)	cl.Length (cm)	Weight (g)	Diameter R/S (mm)	Sect
CDONE02	6'	50-80	138	680	14,60	1+U.B.
CDONE03	6'6"	30-50	158	690	14,40	1+U.B.



TWIST

XXT

ACTION 3

Già da anni Colmic esegue test su canne con anelli a spirale tipo "Acid Rod". Fino a poco tempo fa non era soddisfatta di entrare sul mercato con qualcosa di usual.

For years Colmic has performed tests on rods wearing "Acid Rod" spiral guides. Until recently she was not satisfied to enter the market with something usual.

CODE	Length (m)	Casting W. (lb)	cl.Length (cm)	Weight (g)	Diameter R/S (mm)	Sect
CDTW00	6'	20-30	138	630	12,80	1+U.B.
CDTW01	6'	30-50	138	645	13,20	1+U.B.
CDTW02	6'	50-80	138	680	14,60	1+U.B.
CDTW03	6'6"	30-50	158	690	14,40	1+U.B.



HIGH QUALITY COMPONENTS

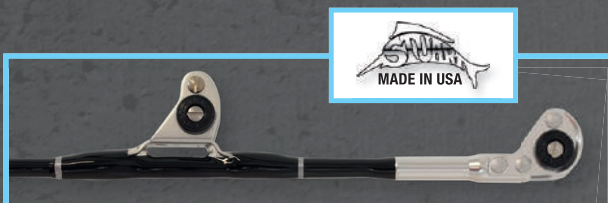

BIG GAME



TROLLING ACID SYSTEM

2018

NEW

COLMIC

51

CANNE \ RODS

www.colmic.it

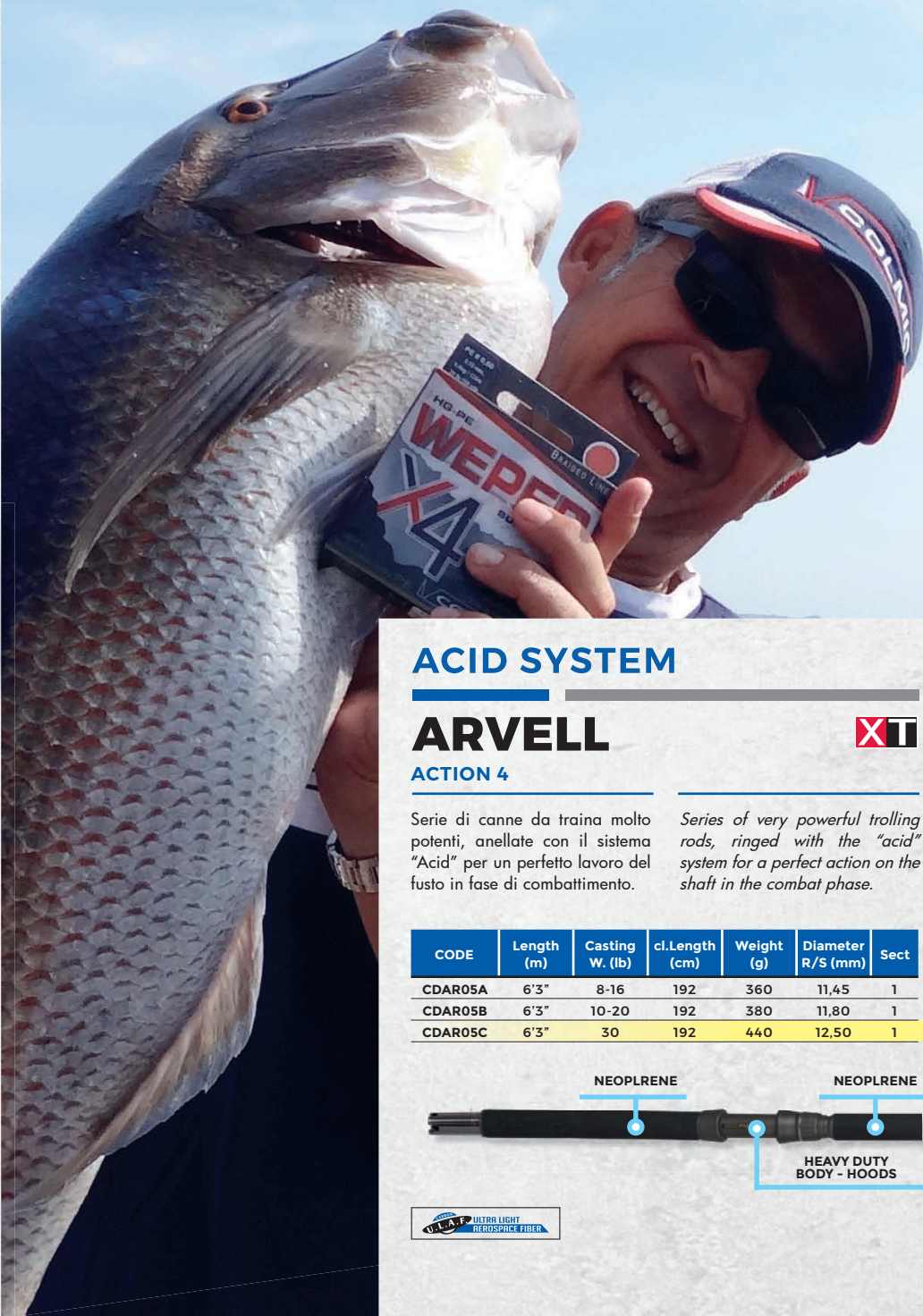

ACID SYSTEM

ARVELL



ACTION 4

Serie di canne da traina molto potenti, anellate con il sistema "Acid" per un perfetto lavoro del fusto in fase di combattimento.

Series of very powerful trolling rods, ringed with the "acid" system for a perfect action on the shaft in the combat phase.

CODE	Length (m)	Casting W. (lb)	cl.Length (cm)	Weight (g)	Diameter R/S (mm)	Sect
CDAR05A	6'3"	8-16	192	360	11,45	1
CDAR05B	6'3"	10-20	192	380	11,80	1
CDAR05C	6'3"	30	192	440	12,50	1

SPECIALE TUNA



HIGH QUALITY COMPONENTS



SERIES: XB
STONE: SIC
FRAME COLOR:
FROSTED GUN SMOKE

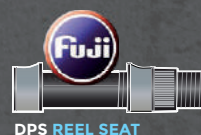

TROLLING

XT

PRO LIGHT WHITE SERIES

ACTION 4

Ideale sia per la traina costiera con esca viva sia con artificiale. Potenza e leggerezza dei materiali sono le caratteristiche vincenti.

Its ideal use is for the trolling either as live baits as artificial. The winning material's features are power and lightness.

CODE	Length (m)	Casting W. (lb)	cl.Length (cm)	Weight (g)	Diameter R/S (mm)	Sect
CDPRW01A	7'	4-8	214	365	25	1
CDPRW01B	7'	6-12	214	390	25	1
CDPRW01C	7'	12-20	214	390	25	1
CDPRW01D	7'	20-30	214	395	25	1



ACID SYSTEM

ACID SYSTEM

XT

PRO LIGHT ACID TROLL

ACTION 4

Canne da traina in carbonio alto modulo, potenti e leggere. L'annellatura montata con il sistema "Acid", garantisce un perfetto lavoro del fusto durante i combattimenti.

High module trolling rod in carbon, powerful and light. The rings mounted with the "Acid" system guarantees perfect shaft actions during combats.

CODE	Length (m)	Casting W. (lb)	cl.Length (cm)	Weight (g)	Diameter R/S (mm)	Sect
CDPRA01A	6'6"	4-8	203	340	10,10	1
CDPRA01B	6'6"	6-12	203	350	10,40	1
CDPRA01C	6'6"	12-20	203	363	11,40	1
CDPRA01D	6'6"	20-30	203	370	11,80	1
CDPRAC01A	7'	4-8	212	362	10,40	1
CDPRAC01B	7'	6-12	212	369	10,80	1
CDPRAC01C	7'	12-20	212	383	11,80	1
CDPRAC01D	7'	20-30	212	389	12,20	1

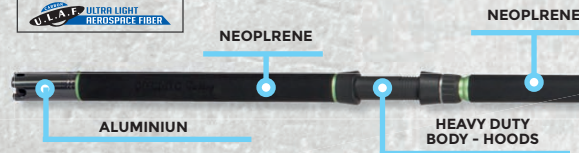

HIGH QUALITY COMPONENTS



SERIES: XB
STONE: SIC
FRAME COLOR:
FROSTED GUN SMOKE

SERIES: CR
STONE: SIC
FRAME COLOR: BLACK

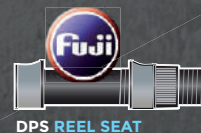
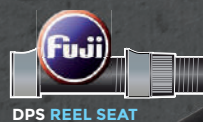

LANDING NET HANDLES

2018

NEW

COLMIC

53

MANICI DI GUADINO
LANDING NET HANDLES

www.colmic.it

PREMIUM - NX **XXT**

PUT-OVER

Questo gioiello di casa Colmic, si distingue per un bilanciamento ed una leggerezza senza pari. Il particolare diametro dei pezzi base, è compatibile inoltre con i kit carpa in quattro sezioni, consentendo quindi il loro uso come prolunghe per i kit. Si potrà ottenere così una robustissima e pratica mini roubaisienne.

This latest gem from Colmic is distinguished by a peerless balance and lightness. The specific diameter of the base sections also mean that it is compatible with the 4-section carp kits, so that they can also be used as extensions for the kits. In practice, this means that you can also have a very strong and practical mini Roubaisienne.

CODE	Length (m)	cl.Length (cm)	Weight (g)	Diameter (mm)	Sect
GXPR50A	4,30	160	320		3
GXPR50B	5,70	160	460	37,50	4



1° SECTION



BRASS SCREW

1° & 2° SECTIONS



TITANIUM REINFORCE

SPECI - PLUS **XT**

PUT-OVER

Guadino studiato e creato per i big da carpodromo e per tutte le situazioni di pesca dove abbiamo a che fare con pesci di grandissima taglia.

This landing net pole has been expressly developed for carpodrome fishing and for all the big specimens fishing in general.

CODE	Length (m)	cl.Length (cm)	Weight (g)	Diameter (mm)	Sect
GXSP31A	3,60	155	425	29,8	3

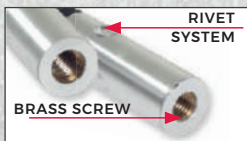

RIVET SYSTEM

BRASS SCREW



LANDING NET HANDLES

DAKA FORCE

XT

PUT-OVER

Guadino da competizione ad innesti. Il Daka Force è un binomio di leggerezza e maneggevolezza abbinata ad una affidabilità unica.

This is a competition put over landing net pole, the Daka Force features an incredible lightness and manageability and is totally reliable.

CODE	Length (m)	cl.Length (cm)	Weight (g)	Diameter (mm)	Sect
GXDA01A	4,20	130	370	28,90	4
GXDA01B	5,20	130	490	30,10	5



1°SECTION



BRASS SCREW

BAMBOO

XT

TELESCOPIC + 1°SEC. TAKE-APART

Questo manico per guadino è stato appositamente studiato per affrontare le situazioni di pesca più estreme.

This landing net handle has been specifically designed to meet the most extreme fishing situations.

CODE	Length (m)	cl.Length (cm)	Weight (g)	Diameter (mm)	Sect
GXBA01A	3,00	135	225	27,40	3



1°SECTION



BRASS SCREW



LANDING NET HANDLES

2018

NEW

COLMIC

55

MANICI DI GUADINO
LANDING NET HANDLES

www.colmic.it

BOSTON

XT

TELESCOPIC

Manico veramente robusto, con una down-force notevole; questo lo rende senz'altro adatto alla competizione, ma anche alla pesca per diletto.

Very strong landing net pole, the great down force make it suitable for both competition and leisure fishing.

CODE	Length (m)	cl.Length (cm)	Weight (g)	Diameter (mm)	Sect
GXBO01A	4,00	112	280	26,50	4
GXBO01B	5,00	112	390	20,20	5



ERNEST

XS

TELESCOPIC

Guadino in Mix - Carbon, affidabile, robusto viene usato, sia dagli agonisti, che da chi pesca per diletto, in quanto risulta maneggevole e leggero.

Very strong telescopic landing net in Carbon-Mix. It is suitable both as a reserve net for competition anglers and for anyone looking for a good, light and manageable landing net.

CODE	Length (m)	cl.Length (cm)	Weight (g)	Diameter (mm)	Sect
GXER60A	3,00	112	245	24,90	3
GXER60B	4,00	112	368	28,70	4
GXER60C	5,00	112	485	31,90	5



MIX CARBON

LEGON

XS

TELESCOPIC - MINI LANDING NET HANDLE

Maneggevole, rigido e molto robusto, ideale per le più svariate tecniche di pesca. Semplicissimo da essere trasportato grazie al suo ingombro contenuto.

It is handy and stiff, the LEGON is suitable for all fishing techniques. Very simple to carry thanks to its small encumbrance.

CODE	Length (m)	cl.Length (cm)	Weight (g)	Diameter (mm)	Sect
GXLE10A	2,00	45	230	25,18	6
GXLE10B	2,50	45	280	28,00	7
GXLE10C	3,00	54	330	30,50	8

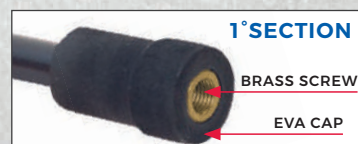

MIX CARBON



MINI LANDING NET HANDLE

45cm (2m - 2.5m) - 54cm (3m)

REELS TECHNOLOGY

2018

NEW

COLMIC

NEW COLLECTION



BRASS PINION GEAR

Il pignone, insieme all'alberino centrale, è il cuore di un buon mulinello. E' su questo pezzo che tutti gli sforzi vengono scaricati ed è questo pezzo che dà la fluidità e la morbidezza del recupero. Quindi per una parte così importante su tutti i nostri migliori modelli sono stati montati pignoni in bronzo, inattaccabile dalla ruggine e con una grande capacità di resistenza.

The pinion, together the main assy, is the heart of a good quality reel. Is on this particular gear that all the stress and strains are supported and it is this gear that also gives the smoothness of the retrieve. For such an important part we could not avoid to use, for our top of the range models, bronze pinions, untouchable by the rust and with a great resistance to the wear.



WSM WORM SHAFT MECHANISM

Il saliscendi della bobina è comandato da un pignone con disegno a coclea (Spiraliforme), in modo da ridurre al minimo gli attriti e da rendere tutto il meccanismo il più solidale possibile. Grazie al Worm Shaft la sequenza di avvolgimento avviene in maniera fluida e rende più agevole sia il recupero che l'azione della frizione. Con questo sistema, le oscillazioni della bobina sono pressoché nulle e il nylon viene avvolto sulla bobina con una sequenza a spire parallele, con la giusta tensione e senza particolari torsioni.

The in and out movement of the reel is governed by a pinion with a Spiral design in order to reduce the friction to the minimum and to make the mechanism as integral as possible. Thanks to the Worm Shaft, the winding sequence happens in a fluid manner and makes the recovery as well as the brake action less demanding. With this system, the oscillations of the reel are more or less nil and the nylon is wound onto the reel with a sequence of parallel spirals, with the correct tension and without particular torsion.



PARALLEL WINDING SYSTEM

Il mulinello è fornito di un sistema di oscillazione della bobina che permette di avvolgere il filo sulla bobina in modo parallelo e non incrociando o sovrapponendo le spire. Questa soluzione tecnica ha una funzione molto importante per vari motivi pratici: permette di preservare il filo che quindi ha una durata più lunga e mantiene uno standard di performance per un periodo maggiore. Permette di fare lanci molto più lunghi, in quanto il filo non è impedito nella fuoriuscita da spire che si sovrappongono e frenano le une con le altre. Mantiene i moderni fili con assenza di memoria nella stessa qualità con cui sono imbobinati in origine, quindi ne permette la migliore prestazione sia in fase di lancio che durante il combattimento.

The reel is provided of a special oscillation system of the spool, it allows to wind the line on the spool in a parallel way and not by the usual crosswinding or over-under spirals. This technical solution has a very important function for many practical reasons: allows to preserve the line that so has a longer lasting and keep its performance standards for a longer time. Allows to make longer casts, because the line has no hindrances during the flow by unliked over-under spirals that obstruct one to each other. Keep the modern lines with no memory at the same quality as when they have been spooled originally, and so allows the best performance for both casting and fighting situations.

5 | 6

MULINELLI \ REELS

www.colmic.it



DRAG CARBON WASHER

L'efficacia di una buona frizione del mulinello è determinata non solo dal numero dei dischi interni che la compongono (organi frizionanti), ma anche dal materiale con cui questi sono costruiti. Nei mulinelli di fascia medio bassa (oggetti per i quali non è necessario utilizzare grosse forze) si usano solitamente dischi in alluminio, mentre per quelli di fascia alta vengono preferiti dischi in carbonio, i quali determinano minori attriti, maggiore leggerezza ed una durata sicuramente superiore. I dischi frizione in carbonio, favoriscono inoltre una regolazione molto più precisa della frizione (cosiddetta "micrometrica"), dove appunto già con un semplice "clic" in positivo o in negativo, si riesce a determinare una maggior frenata o un maggior scorrimento della bobina, cosa che non avviene con dischi di materiale più scadente. Il logo DRAG CARBON WASHER, contraddistingue quindi dei mulinelli di alta gamma.

The effectiveness of good friction on the fishing reel is determined not only by the number of internal discs which make it up (braking unit), but also by the materials from which these are made. In medium to low band reels (for which it is not necessary to use great force), discs of aluminium are normally used, while for those in the higher bands, carbon discs are preferred as they show less wear, are much lighter and have a decidedly longer life. The carbon braking discs allow for a much more precise adjustment to the braking (so called "micrometric"), where indeed, with just a simple positive or negative "click", Greater braking or free running of the reel is obtained, a result not obtained from lower quality materials. The logo DRAG CARBON WASHER therefore distinguishes the high level fishing reels.



SALT WATER PROTECTION

Tutti i mulinelli Colmic caratterizzati da questa sigla, sono stati sottoposti ad un particolare trattamento anti corrosione, il quale oltre che ha prevenire l'ossido, rende praticamente inattaccabili dalla salsedine i meccanismi interni del mulinello. Ogni singola componente degli ingranaggi, subisce una speciale finitura ed il corpo viene isolato completamente, tramite un sistema molto simile al sotto vuoto. Questa sigla, è sinonimo di ulteriore qualità e contraddistingue molti dei nostri prodotti destinati alle acque salse.

All the Colmic reels featuring these initials have been subjected to a special rustproofing treatment which, as well as preventing oxidation also keeps the internal mechanisms of the reel practically intact from corrosion deriving from the action of salt water. Every single component of the drag gears undergoes a special finish and the body is completely isolated, exploiting a system very similar to that of vacuum packing. These initials are synonymous with superior quality, and are the hallmark of a wide range of the products destined to sea water.



POWER LINE ROLLER ANTI TWIST

Il rullino scorrifile è uno dei punti più critici in un mulinello ed è quasi sempre poco considerato. Un rullino scorrifile ben costruito sia nel materiale che nel profilo, permette di preservare il monofilo per lungo tempo e evita possibili parrucche in fase di recupero.

The line roller is one of the most critical points of a reel, and it is quite always under-estimated. A well made line roller, in terms of material and shape, allows to keep the line qualities performing for a longer time and avoid any eventual line tangles during the retrieve.



COMPUTER BALANCED ROTOR

Il bilanciamento della bobina è fondamentale per evitare vibrazioni nel recupero. La rotazione generata durante la fase di recupero, specialmente se ad alta velocità, viene esaminata da un sistema computerizzato che provvede ad indicare in quale punto del rotore bisogna intervenire per bilanciare ed equilibrare, proprio come si fa nelle ruote di un'automobile.

The rotor and spool balancing is highly important in order to avoid vibrations during the retrieve. The rotation generated during the retrieve, especially if it is a high speed ratio, is monitored by a computer system that gives the indication where is the precise point in which must be added a weight to balance and make equilibrate the spool, in principals the same operations used for the setting of a car tyres.



ONE WAY ANTI REVERSE

Il One Way System è un sistema di antiritorno infinito, dove lo sbloccaggio è determinato dal disinserimento di un cuscinetto a rulli unidirezionale che appunto sblocca il rotore. Tale procedura avviene tramite una levetta posta generalmente sopra o sotto il corpo mulinello. Quando il meccanismo è inserito il cuscinetto è sempre in presa diretta sulla meccanica e quindi sulla manovella.

The One Way System is an infinite backstop system, where blocking is determined by the disconnection of a uni-directional roller bearing which unblocks the rotor. This procedure is actioned by a small lever normally positioned above or below the body of the reel. When the mechanism is inserted, the bearing is always directly engaged on the mechanism and, therefore, on the crank.



CNC HANDLE

Il procedimento CNC è fornito da un tornio con controllo numerico del taglio, quindi estremamente preciso. Queste manovelle sono create dal pieno con queste macchine in alluminio, che garantisce una durata infinita, una grande robustezza ma con un peso molto ridotto. Usate normalmente su mulinelli di grande potenza e destinati ad un uso con prede impegnative.

The CNC process is performed by a numeric controlled cutting lathe, so extremely precise and accurate. These handles have been developed and tooled by a solid piece of aluminium, that ensures an everlasting life, a great strength but with a very light weight. Are normally used on big power reels aimed for the use with important preys.



NAIL BAIL HOLDER

Rullino guidafilo disegnato per aiutare e guidare al massimo il filo nella fase di recupero. La forma ad unghia permette al filo di scivolare molto più velocemente e senza pericolose torsioni all'interno del guidafilo, normalmente dotato di cuscinetto a sfera.

New concept line roller, designed to help and lead the line during the retrieve. The special nail shape allows the line to slide much faster and without dangerous torsions inside the line roller, normally provided of a ball bearing.

PROFESSIONAL REELS

SPECIAL MATCH & FEEDER

COMPACT BODY COMBINED WITH BIG ROTOR & BIG SPOOL



SUPER STRONG GRAPHITE BODY & ROTOR

ULTRA LIGHT ALUMINUM SPOOL

WATERPROOF BODY & ROTOR

WATERPROOF DRAG SYSTEM

GRAPHITE REEL

AMUNK

Questa serie di mulinelli è stata studiata e realizzata curando ogni dettaglio sia meccanico che estetico. Proposti in 4 versioni gli Amunk, coprono le diverse necessità che le varie tecniche di pesca richiedono, differenziandosi nel rapporto di recupero e materiale di costruzione. Tutta la serie è dotata di frizione multidisco a regolazione micrometrica e di ben 10 cuscinetti a sfera stainless steel, molti dei quali completamente stagni. I corpi ed i rotori sono stati realizzati in waterproof system, rendendoli impermeabili ad infiltrazioni di acqua ed umidità salvaguardando i meccanismi interni. Tutte le bobine sono match (a bassa capacità) e sono state realizzate in alluminio da un unico blocco forgiato a freddo e doppia clip ferma filo con ammortizzatore. Una caratteristica importante è che nelle misure 4500, sono state messe bobine a bassa capacità con diametri più grandi rispetto ad altri mulinelli della stessa categoria abbinati a corpi davvero compatti e leggeri.

This series of reels has been designed and created with care for every detail, be that mechanical or aesthetic. Offered in 4 versions, they cover the many needs which the various fishing techniques require, differing with regard to recovery and construction materials. The whole series is equipped with a multi-disc clutch with micrometer adjustment, and with no less than 10 stainless steel ball bearings, many of which are completely sealed. The bodies and spools are made as a waterproof system, making them impermeable to infiltrations of water and humidity, safeguarding the internal mechanisms. All the reels are match grade (low capacity) and have been made out of aluminium from a single cold-forged block, with double clip line blocker and shock absorber. An important characteristic is that in the 4500 sizes, low capacity reels have been included with larger diameters compared with other reels of the same category, coupled with bodies which are really compact and light.



Item	CODE		Line Capacity (mm/m) Aluminum Spool		
AMUNK 3500	MULAMU35	5.1:1	0,185/200 - 23/150	80cm	270
AMUNK 3500S	MULAMU35S	6.1:1	0,185/200 - 23/150	90cm	270
AMUNK 4500	MULAMU45	5.1:1	0,20/200 - 25/150	90cm	285
AMUNK 4500S	MULAMU45S	6.1:1	0,20/200 - 25/150	100cm	285

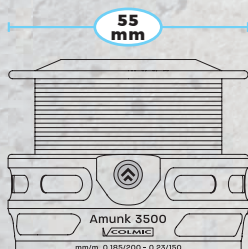

3500/3500S

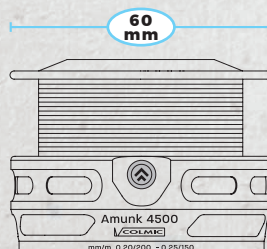

4500/4500S

2018

NEW

COLMIC

58

MULINELLI \ REELS

www.colmic.it

PROFESSIONAL REELS

2018

NEW

COLMIC

59

MULINELLI \ REELS

www.colmic.it

ULTRA COMPACT BODY COMBINED WITH BIG ROTOR & BIG SPOOL

SPECIAL MATCH & FEEDER

SUPER STRONG CARBON BODY & ROTOR

ULTRA LIGHT ALUMINUM SPOOL

CARBON REEL



- X2 SOFT DAMPING LINE CLIP
- BRASS PINION GEAR
- COMPUTER BALANCED ROTOR
- POWER LINE ROLLER ANTI-TWIST
- ONE WAY ANTI REVERSE
- PARALLEL WINDING SYSTEM
- NAIL BALL HOLDER
- CNC HANDLE



KIGER CARBON

Il mulinello KIGER è stato studiato e realizzato nella cura di ogni dettaglio sia meccanico sia estetico. Questo mulinello viene proposto in due misure 4000 e 5000 entrambi con un rapporto di recupero di 5.0:1. I mulinelli KIGER hanno un corpo compatto e sono dotati di bobine a bassa capacità con diametri più larghi rispetto alla sua categoria. La loro frizione micrometrica e i 10+1BB stainless steel, rendono il mulinello KIGER ideale sia per l'agonismo sia per tutti i pescatori che prediligono qualità ed affidabilità.

The KIGER reel has been studied and realized in the care of every mechanical and aesthetic detail. This reel is proposed in two sizes 4000 and 5000 both with a recovery report of 5.0:1. The Kiger reels have a compact body equipped with low capacity reel with diameters wider than its category. Their micrometric clutch and the 10+1BB stainless steel, make the reel KINGER suitable both for the agonist and for all the fishermen who prefer quality and reliability.



Item	CODE	5.0:1	Line Capacity (mm/m) Aluminum Spool		g
KIGER 4000	MULKIG40	5.0:1	0,185/220 - 0,22/170	85cm	260
KIGER 5000	MULKIG50	5.0:1	0,205/230 - 0,26/170	95cm	266

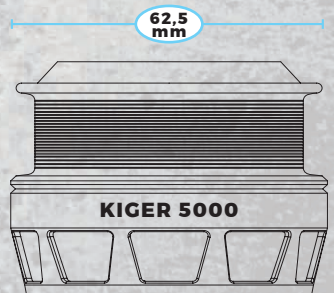
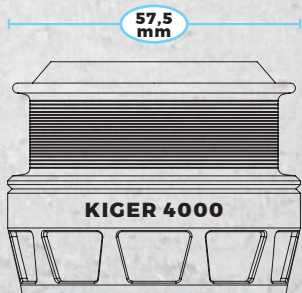

PROFESSIONAL REELS

GRAPHITE
BODY & ROTOR



**BOLO
MATCH
SPINNING**

VRZ

Il VRZ è un mulinello accattivante dal corpo compatto e le sue bobine ultramatch (di dimensioni più grandi delle classiche bobine), lo rendono efficiente sia per la pesca con l'inglese sia per la pesca a bolognese e feeder. La sua frizione micrometrica e i 10 cuscinetti a sfera stainless steel di cui è dotato, rendono il VRZ un mulinello versatile ed efficiente in qualsiasi situazione di pesca.

The VRZ is an attractive reel with a compact body and its ultramatch coils (bigger than the classic reels), make it efficient both for English fishing and for Bolognese and feeder fishing. Its micrometric drag reel and the 10 stainless steel ball bearings with which it is equipped make the VRZ a versatile and efficient reel in any fishing situation.

EVA KNOB

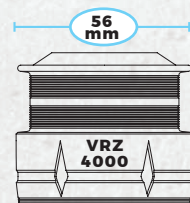
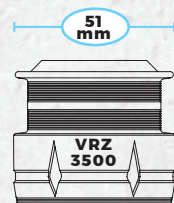
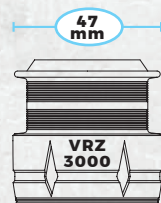
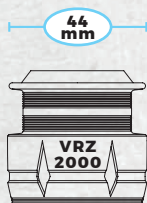

Item	CODE	Gear Ratio	Line Capacity (mm/m) Aluminum Spool	Length
VRZ 2000	MULVRZ20	5.4:1	0,165/180 - 0,185/150 - 0,20/120	65cm
VRZ 3000	MULVRZ30	5.2:1	0,20/200 - 0,22/160 - 0,235/130	70cm
VRZ 3500	MULVRZ35	5.2:1	0,22/200 - 0,235/170 - 0,25/140	75cm
VRZ 4000	MULVRZ40	4.9:1	0,185/180 - 0,205/150 - 0,22/120	80cm



PROFESSIONAL REELS

2018

NEW

COLMIC

6

MULINELLI \ REELS

www.colmic.it



BOLO MATCH SPINNING

ROG

Solido, fluido ed ottimo per essere impiegato quando l'affidabilità è una necessità imprescindibile. Corpo robusto, ingranaggi resistenti e frizione facilmente regolabile sono solo alcune delle caratteristiche del Rog. Le due misure disponibili sono adatte per essere usate per le pesca in mare ed in acqua dolce.

Solid, fluid and excellent to be used when reliability is essential. Sturdy body, resistant gears and easily adjustable drag reel are just a few of the characteristics of the Rog. The two available sizes are suitable to be used for fishing at sea and in fresh water.

Item	CODE		Line Capacity (mm/m) Aluminum Spool	
ROG 2500	MULROG25	5.1:1	0,16/200 - 0,20/150	65cm
ROG 3500	MULROG35	5.1:1	0,18/200 - 0,23/150	75cm

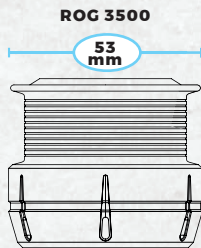
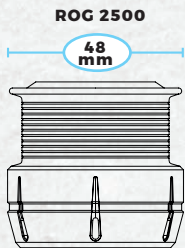

GRAPHITE BODY & ROTOR



SPECIAL LIGHT SPINNING TROUT AREA

EVER 1000

L'EVER 1000 è un mulinello con frizione anteriore a regolazione micrometrica proposto in unica misura "1000" ideale per il trout area e tutte le discipline light spinning. Ideale inoltre per essere abbinato a canne "barbarine" per la pesca in passata in fiume.

The EVER 1000 is a reel with front drag reel with micrometric adjustment offered in a single "1000" size, ideal for the trout area and all light spinning disciplines. It is also ideal to combine with "barbarine" rods for river fishing.

Item	CODE		Line Capacity (mm/m) Aluminum Spool	
EVER 1000	MULEVE10	5.1:1	0,14/150 - 0,16/100	60cm



GRAPHITE BODY & ROTOR

PROFESSIONAL REELS



GRAPHITE
BODY & ROTOR





**BOLO
MATCH
SPINNING**

ETAN

Mulinello dotato di frizione anteriore con regolazione micrometrica. Questo mulinello viene proposto in tre differenti misure ideali a coprire tutte le tecniche di pesca sia in acqua dolce che in mare.

Reel equipped with front drag reel with a micrometric adjustment. This reel is offered in three different sizes, ideal to cover all fishing techniques, whether in freshwater or in the sea.

Item	CODE		Line Capacity (mm/m) Aluminum Spool	
ETAN 2500	MULETA25	5.1:1	0,16/300 - 0,18/200	60
ETAN 3500	MULETA35	5.1:1	0,18/350 - 0,20/250	65
ETAN 5000	MULETA50	5.1:1	0,25/330 - 0,30/220	80

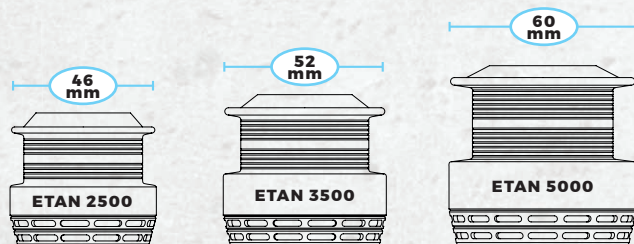

GRAPHITE
BODY & ROTOR





**BOLO
MATCH**

TIFF

Fluidità e versatilità sono i cavalli di battaglia del TIFF. Si tratta di un mulinello a frizione anteriore adatto per tutti i tipi di pesca in cui l'affidabilità sia il requisito fondamentale. Le due misure disponibili permettono di rispondere alle esigenze di spinning, feeder, bolognese, ledgering e molte altre tecniche sia in acqua dolce che salata.

Fluidity and versatility are the driving forces of the TIFF. This is a front friction reel suitable for all types of fishing where reliability is the fundamental requirement. The two available sizes make it possible to meet your needs for spinning, feeder, bolognese, ledgering technique, and many other techniques in both freshwater and salt water.

Item	CODE		Line Capacity (mm/m) Aluminum Spool	
TIFF 3000	MULTIF30	5.2:1	0,18/200 - 0,20/150	70cm
TIFF 3500	MULTIF35	5.2:1	0,20/200 - 0,22/150	80cm

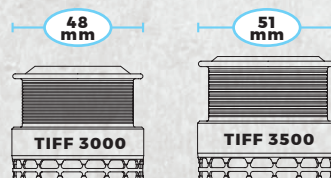

PROFESSIONAL REELS

2018

NEW

COLMIC

63

MULINELLI \ REELS

www.colmic.it

GRAPHITE
BODY & ROTOR



BOLO
SPINNING

BASKER

Il Basker è un mulinello dal corpo compatto con frizione anteriore e regolazione micrometrica. L'ampia scelta tra le versioni disponibili, consente di trovare l'oggetto adatto a qualsiasi situazione di pesca light e medium-light.

The Basker is a reel with a compact body with a micrometrically adjustable front drag reel. The wide range of available versions allows you to find the object suitable for any light and medium-light fishing situation.

Item	CODE	5.0:1	Line Capacity (mm/m) Aluminum Spool	
BASKER 2500	MULBAS25	5.0:1	0,16/230 - 0,18/180	60cm
BASKER 3500	MULBAS35	5.0:1	0,18/230 - 0,20/180	65cm
BASKER 4500	MULBAS45	5.0:1	0,25/250 - 0,23/180	75cm
BASKER 5500	MULBAS55	5.5:1	0,30/180 - 0,35/120	85cm

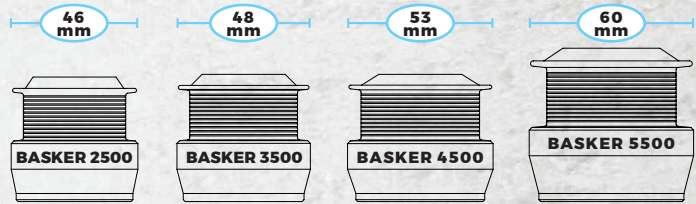

PROFESSIONAL REELS

GRAPHITE
BODY & ROTOR

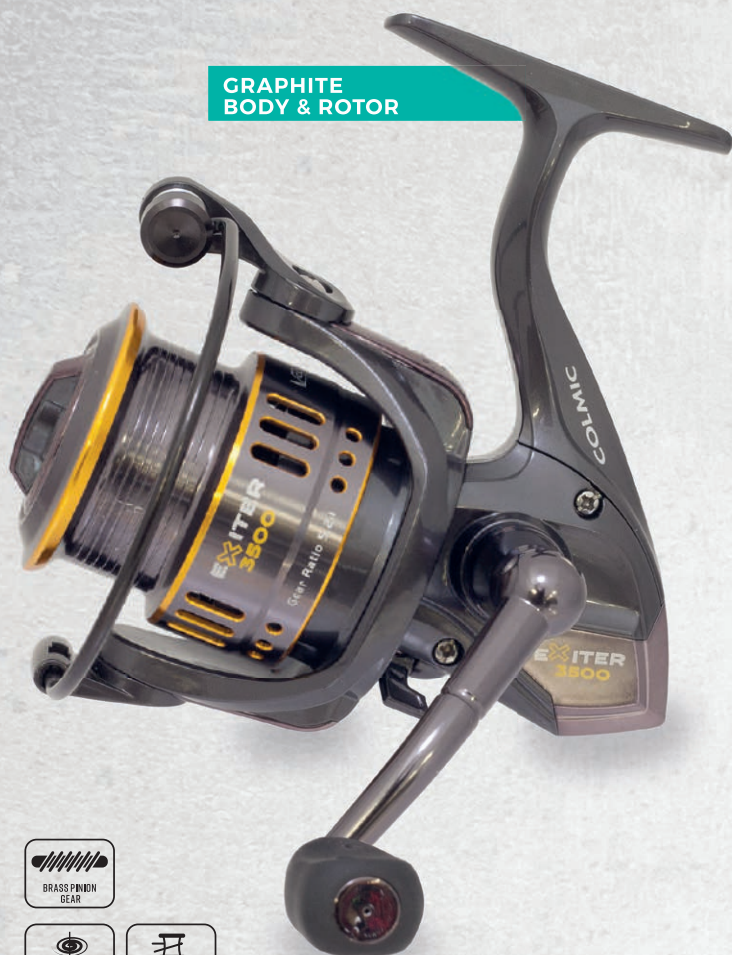

**LIGHT SPINNING
SPINNING
BOLO - BOLENTINO**

EXITER

L'Exiter è un mulinello dal corpo compatto con frizione anteriore a regolazione micrometrica. La sua vasta scelta nelle dimensioni che vanno dalla misura 500 ottima per il Trout Area fino ad un 6000 ottimo per il bolentino e tutte le tecniche di pesca a fondo.

The Exiter is a reel with a compact body with a micrometrically adjustable front drag reel. Its wide choice in sizes ranging from 500, great for the Trout Area up to 6000, great for trolling rod fishing and all deep-sea fishing techniques.

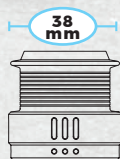

EXITER 500

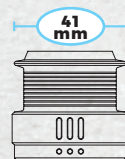

EXITER 1000

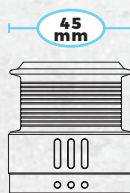

EXITER 2500

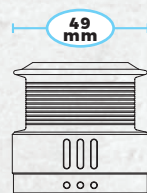

EXITER 3500

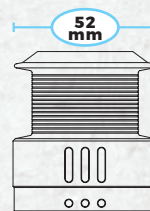

EXITER 4500

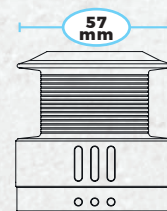

EXITER 6000

Item	CODE	5.2:1	Line Capacity (mm/m) Aluminum Spool	
EXITER 500	MULEX105	5.2:1	0,125/250 - 0,145/200	55
EXITER 1000	MULEX110	5.2:1	0,145/250 - 0,16/200	60
EXITER 2500	MULEX125	5.2:1	0,16/250 - 0,20/180	65
EXITER 3500	MULEX135	5.2:1	0,18/250 - 0,22/170	75
EXITER 4500	MULEX145	5.2:1	0,25/230 - 0,30/170	75
EXITER 6000	MULEX160	5.2:1	0,30/250 - 0,35/170	80



ALL ROUND

MORK

Mulinello all round a frizione anteriore destinato a chi vuole un oggetto semplice da usare per divertirsi all'aria aperta e godersi la gioia della pesca.

Mork is an all round front drag reel, especially conceived for the anglers requiring a simple and yet functional product to fully enjoy the leisure of fishing.

Item	CODE	5.2:1	Line Capacity (mm/m) Graphite Spool	
MORK 20	MULMOR20	5.2:1	0,18/350 - 0,20/270	60
MORK 40	MULMOR40	5.2:1	0,22/380 - 0,25/300	70
MORK 60	MULMOR60	5.2:1	0,30/320 - 0,35/250	75

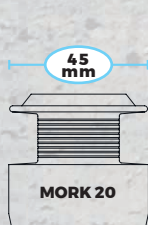

MORK 20

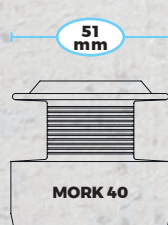

MORK 40

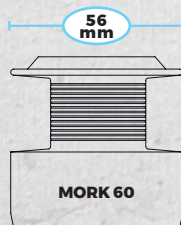

MORK 60

GRAPHITE
BODY & ROTOR



PROFESSIONAL REELS

2018

NEW

COLMIC

51

MULINELLI \ REELS

www.colmic.it

SPECIAL TROLLING



WTR

Il corpo costruito in ABS/Graphite e la componentistica interna realizzata con la massima precisione negli assemblaggi, rendono il WTR un mulinello rotante affidabile e duraturo nel tempo. I vantaggi nella scelta di questi mulinelli non sono soltanto riferiti alla qualità ma anche nell'aspetto economico.

The body built in ABS/Graphite and the internal components made with the utmost precision in the assembly, make the WTR a spinning reel that is reliable and long-lasting. The advantages in choosing these reels not only relate to quality, but also include an economic saving.

SIZE	CODE		Line Capacity
WTR 20	MULWTR20	3.2:1	0,20lb/350m
WTR 25	MULWTR225	3.2:1	0,30lb/350m

SURF & BEACH

2018

NEW

COLMIC

6

MULINELLI \ REELS

www.colmic.it



GRAPHITE BODY & ROTOR

ULTRA LIGHT SPOOL



DRAG CARBON WASHER

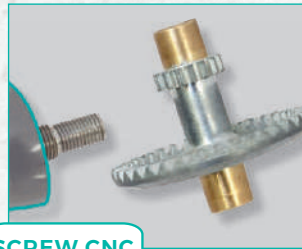

SCREW CNC HANDLE

ULTRA LIGHT SURF CASTING REEL

EVA KNOB



EXTRA ALUMINUM SPOOL



KROMER 8000

Mulinello a bobina fissa e frizione anteriore studiato per il surf casting. Dotato di bobina match ultra-light a bassa capacità, frizione con dischi in carbonio e pomello in Eva, questo mulinello è destinato agli agonisti e a tutti gli amanti del Surf Casting che pretendono sempre il meglio sul mercato.

Fixed reel and front drag reel designed for surfcasting. Equipped with a low capacity ultra-light match coil, drag reel with carbon discs and EVA knob, this reel is intended for athletes and all Surf Casting lovers who always demand the best on the market.



BRASS PINION GEAR

WSM WORM SHAFT MECHANISM

Item	CODE	Line Capacity (mm/m) Aluminum Spool	Length	Weight
KROMER 8000	MULKRO80A	4.6:1 0,18/300 - 0,20/250	105cm	520

Item	Line Capacity (mm/m) Aluminum Spool	Length
EXTRA SPOOL	0,35/380 - 0,45/280	105cm

SURF & BEACH

2018

NEW

COLMIC

67

MULINELLI \ REELS

www.colmic.it



AULUS 5500

L'AULUS nasce con dieci cuscinetti a sfera sigillati ed inossidabili, per prevenire totalmente la corrosione derivante dall'azione della salsedine. L'ampiezza della bobina lo rende ideale per tutte le tecniche di pesca a fondo, sia in mare che in acque interne, ed anche per molte delle tecniche praticabili da natante.

The AULUS born with ten sealed and stainless ball bearings to completely prevent corrosion due to the action of the salt. The amplitude of the coil makes it ideal for all deep sea fishing techniques, both at sea and in inland waters, and also for many of the techniques practised by boat.



GRAPHITE BODY & ROTOR

Item	CODE		Line Capacity (mm/m) Aluminum Spool		
AULUS 5500	MULAU01A	5.0:1	0,20/370 - 0,25/300	90cm	510

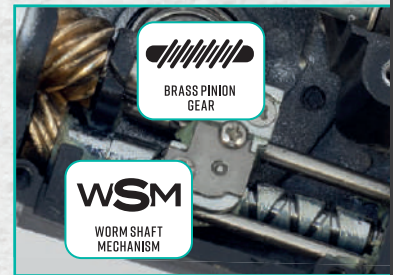

GRAPHITE BODY & ROTOR



KHETAMON 8000

Questo mulinello per il surf casting e per la pesca a fondo in acqua dolce, è caratterizzato da un eccellente rapporto qualità/prezzo. Il Khetamon 8000 ha una bobina match in alluminio a bassa capienza e viene corredato di una seconda extra bobina in graphite più capiente.

This reel for surfcasting and for deep-sea fishing in fresh water, is characterized by an excellent quality/price ratio. The Khetamon 8000 has a low capacity aluminium match coil and comes with a second extra graphite coil with larger capacity.

Item	CODE		Line Capacity (mm/m) Aluminum Spool		
KHETAMON 8000	MULKH80A	4.1:1	0,18/350 - 0,22/250	90cm	620

EXTRA GRAPHITE SPOOL

Item	Line Capacity (mm/m) Graphite Spool	
EXTRA SPOOL	0,30/450 - 0,40/300	90cm

2018

NEW

COLMIC

68

MULINELLI \ REELS

www.colmic.it

PROFESSIONAL REELS

SPECIAL TUNA

ALUMINUM SPOOL

ALUMINUM BODY & ROTOR



HIGH POWER

POWER DRAG 40lb



APODIS 6000

Il mulinello APODIS è ideale per tutte le pesche in cui la potenza e l'affidabilità sono requisiti imprescindibili.

Questi mulinelli sono dotati di albero e ingranaggi in acciaio sovradimensionati e cuscinetti stagni, che rendono il tutto l'ideale per provare l'emozione della pesca da natante a tutti i grandi pelagici. Potenza e resistenza del mulinello APODIS 6000 sono i requisiti necessari per non scendere a compromessi.

The APODIS reel is ideal for all types of fishing where power and reliability are essential. These reels are equipped with shaft and oversized steel gears, watertight bearings, which make them ideal for experiencing the thrill of boat-fishing to all large pelagics. Power and resistance of the APODIS 6000 reel are the necessary requirements for not compromising.



DRAG CARBON WASHER

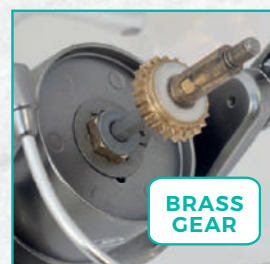

BRASS GEAR

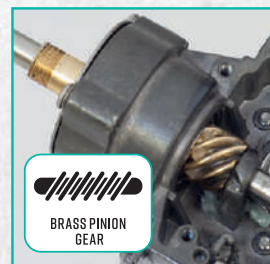

BRASS PINION GEAR



ANTI SALT WATER SEALED DRAG SYSTEM



ONE WAY ANTI REVERSE



BRASS PINION GEAR



DRAG CARBON WASHER



COMPUTER BALANCED ROTOR



POWER LINE ROLLER ANTI TWIST



SALT WATER PROTECTION



PARALLEL WINDING SYSTEM



NAIL BAIL HOLDER



CNC HANDLE

SIZE	CODE	Line Capacity Aluminum Spool	70	638
APODIS6000	MULAPO10	4.7:1 (Nylon) 0.35/420 - 0.45/250 (Braided) 60lb/440yd 80lb/295yd		

PROFESSIONAL REELS

2018

NEW

COLMIC

69

MULINELLI \ REELS

www.colmic.it



ALUMINUM SPOOL

GRAPHITE BODY & ROTOR



ERMES 7000

L'Erme 7000 è un mulinello dalla potenza straordinaria, studiato e concepito per essere utilizzato nelle più svariate discipline, dal mare alle acque interne. Indicato per tutte le tecniche di pesca ed in particolare per il Jigging.

The Erme 7000 is definitely a very fine reel, conceived and designed to be used in various disciplines from sea to inland waters.

Item	CODE	4.1:1	Line Capacity (mm/m) Aluminum Spool		9
ERMES 7000	MULERM70	4.1:1	0,25/300 - 30/250	75	590

FLOATS
TECHNICAL DESCRIPTION

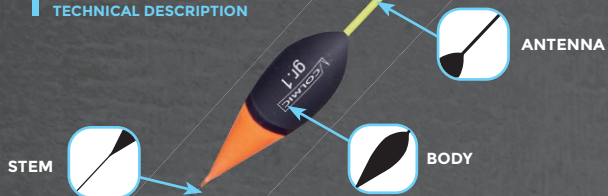

Styl	g.
4x8	0,06
4x10	0,12
4x12	0,212
4x14	0,328
4x16	0,512
4x18	0,704
4x20	1,00
5x20	1,25
6x20	1,50

FLOAT
HIGH
PERFORMANCE

REALIZZATO IN COLLABORAZIONE
CON IL TEAM **VALDERA COLMIC**

VALDERA



CODE: GAVAL01

Size (g)	Ant.φ	Stem.φ	Size (g)	Ant.φ	Stem.φ	Size (g)	Ant.φ	Stem.φ
3,00	1,00	0,70	8,00	1,20	0,80	20,00	1,50	1,00
4,00	1,00	0,70	10,00	1,50	0,80	25,00	1,80	1,00
5,00	1,20	0,80	12,00	1,50	0,80	30,00	1,80	1,00
6,00	1,20	0,80	15,00	1,50	1,00	40,00	1,80	1,00

VALDERA

KEEL



KEEL



CODE: GAKEE01

Size (g)	Ant.φ	Stem.φ	Size (g)	Ant.φ	Stem.φ	Size (g)	Ant.φ	Stem.φ
1,00	1,00	0,60	5,00	1,20	0,80	15,00	1,50	1,00
1,50	1,00	0,70	6,00	1,30	0,80	20,00	1,50	1,00
2,00	1,20	0,70	8,00	1,30	0,90	25,00	1,50	1,00
3,00	1,20	0,70	10,00	1,50	0,90	30,00	1,50	1,00
4,00	1,20	0,80	12,00	1,50	1,00			

RONCO



PLASTIC



BALSA



CARBON

CODE: GARON01

Size (g)	Ant.φ	Stem.φ	Size (g)	Ant.φ	Stem.φ
0,10	0,80	0,60	0,50	1,00	0,60
0,20	0,80	0,60	0,75	1,00	0,60
0,30	1,00	0,60	1,00	1,00	0,60
0,40	1,00	0,60			

CARZA PASSANTE



PLASTIC



BALSA



CARBON

CODE: GACAP01

Size (g)	Ant.φ	Stem.φ	Size (g)	Ant.φ	Stem.φ
0,20	1,20	0,60	3,00	1,50	0,80
0,30	1,20	0,60	4,00	1,50	0,90
0,50	1,20	0,60	5,00	1,80	0,90
0,75	1,20	0,70	6,00	1,80	1,00
1,00	1,20	0,70	8,00	2,00	1,00
1,50	1,50	0,70	10,00	2,00	1,00
2,00	1,50	0,80			

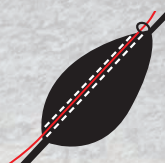

TECHNICAL DESCRIPTION

FILO PASSANTE LATERALE SIDE PASSING LINE

Quando si sposta il galleggiante, il nylon non segna la parete.
When you move the float, the nylon does not mark the wall.



BIDENTE PASSANTE



PLASTIC



BALSA



CARBON

CODE: GABID01

Size (g)	Ant.φ	Stem.φ	Size (g)	Ant.φ	Stem.φ
0,20	1,00	0,60	0,75	1,20	0,70
0,30	1,00	0,60	1,00	1,20	0,70
0,40	1,20	0,70			
0,50	1,20	0,70			



RENO PASSANTE



PLASTIC



BALSA



CARBON

CODE: GAREN01

Size (g)	Ant.φ	Stem.φ	Size (g)	Ant.φ	Stem.φ
0,20	1,20	0,60	1,50	1,50	0,70
0,30	1,20	0,60	2,00	1,50	0,80
0,50	1,20	0,60	3,00	1,50	0,80
0,75	1,20	0,70			
1,00	1,20	0,70			



CARPA NX SERIES

TECHNICAL DESCRIPTION

FILO PASSANTE INTERNO INSIDE PASSING LINE

Filo passante interno con supporto in guaina.

Internal line loop with protective sheath support.

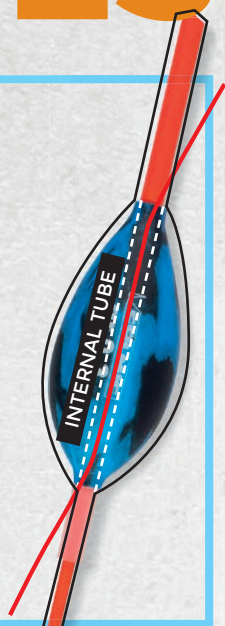

CARPA NX1



CODE: GACANX01

Size (g)	Ant.φ	Stem.φ	Size (g)	Ant.φ	Stem.φ
0,10	1,80	1,00	0,50	1,80	1,00
0,20	1,80	1,00	0,75	1,80	1,00
0,30	1,80	1,00	1,00	1,80	1,00



CARPA NX2



CODE: GACANX02

Size (g)	Ant.φ	Stem.φ	Size (g)	Ant.φ	Stem.φ
0,20	1,50	0,80	0,75	1,50	0,80
0,30	1,50	0,80	1,00	1,50	0,80
0,50	1,50	0,80			



CARPA NX3



CODE: GACANX03

Size (g)	Ant.φ	Stem.φ	Size (g)	Ant.φ	Stem.φ
0,20	1,50	1,00	1,00	1,80	1,00
0,30	1,50	1,00	1,50	1,80	1,00
0,50	1,50	1,00	2,00	1,80	1,00
0,75	1,80	1,00			



CARPA NX SERIES

CARPA NX4



HOLLOW PLASTIC



BALSA



FIBERGLASS

CODE: GACANX04

Size (g)	Ant. Ø	Stem. Ø	Size (g)	Ant. Ø	Stem. Ø
0,20	1,80	1,00	0,75	1,80	1,00
0,30	1,80	1,00	1,00	1,80	1,00
0,50	1,80	1,00	1,50	1,80	1,00



CARPA NXST



HOLLOW PLASTIC



BALSA



FIBERGLASS

CODE: GACANXST

Size (g)	Ant. Ø	Stem. Ø	Size (g)	Ant. Ø	Stem. Ø
0,20	2,20	1,00	0,75	2,20	1,00
0,30	2,20	1,00	1,00	2,20	1,00
0,50	2,20	1,80			

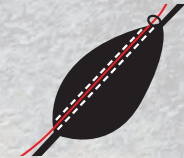

CARPA NX5



HOLLOW PLASTIC



BALSA



FIBERGLASS

CODE: GACANX05

Size (g)	Ant. Ø	Stem. Ø	Size (g)	Ant. Ø	Stem. Ø
0,20	2,00	1,00	0,75	2,00	1,00
0,30	2,00	1,00	1,00	2,00	1,00
0,50	2,00	1,00			



CARPA NX6



HOLLOW PLASTIC



BALSA



FIBERGLASS

CODE: GACANX06

Size (g)	Ant. Ø	Stem. Ø	Size (g)	Ant. Ø	Stem. Ø
0,10	2,00	1,00	0,50	2,00	1,00
0,20	2,00	1,00	0,75	2,00	1,00
0,30	2,00	1,00	1,00	2,00	1,00



EVA SERIES

EXTRA STRONG

EVACARP 1



EVACARP 2



EVATOP



EVANIGHT



TECHNICAL DESCRIPTION

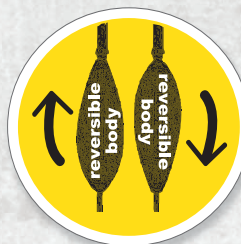

REVERSIBLE BODY

EVACARP 1



CODE: GAEVCA101

Size (g)	Ant.φ	Stem.φ	Size (g)	Ant.φ	Stem.φ
0,10	2,30	0,90	0,50	2,30	0,90
0,20	2,30	0,90	0,75	2,30	0,90
0,30	2,30	0,90	1,00	2,30	0,90



EVACARP 2



CODE: GAEVCA201

Size (g)	Ant.φ	Stem.φ	Size (g)	Ant.φ	Stem.φ
0,10	2,00	0,90	0,50	2,00	0,90
0,20	2,00	0,90	0,75	2,00	0,90
0,30	2,00	0,90	1,00	2,00	0,90



EVATOP



CODE: GAEVTO01

Size (g)	Ant.φ	Stem.φ	Size (g)	Ant.φ	Stem.φ
0,10	3,20	0,60	0,30	3,50	0,70
0,20	3,30	0,60	0,50	3,80	0,70



EVANIGHT



CODE: GAEVN01

Size (g)	Ant.φ	Stem.φ	Size (g)	Ant.φ	Stem.φ
0,10	3,00	1,00	0,50	3,00	1,00
0,20	3,00	1,00	0,75	3,00	1,00
0,30	3,00	1,00	1,00	3,00	1,00

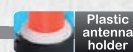

VIAREGGIO PIOMBATO

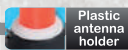

Plastic antenna holder

- PLASTIC
- POLIURETANO
- FIBERGLASS

CODE: GAVIA01

Size (g)	Ant. Ø	Stem. Ø	Size (g)	Ant. Ø	Stem. Ø
0,50+0,50	3,00	1,20	2,25+0,75	3,00	1,20
0,75+0,75	3,00	1,20	3,25+0,75	3,00	1,20
1,25+0,75	3,00	1,20	4,25+0,75	3,00	1,20



NIZZA PIOMBATO

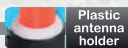

Plastic antenna holder

- PLASTIC
- POLIURETANO
- FIBERGLASS

CODE: GANIZ01

Size (g)	Ant. Ø	Stem. Ø	Size (g)	Ant. Ø	Stem. Ø
0,50+0,50	3,00	1,20	2,25+0,75	3,00	1,20
0,75+0,75	3,00	1,20	3,25+0,75	3,00	1,50
1,25+0,75	3,00	1,20	4,25+0,75	3,00	1,50

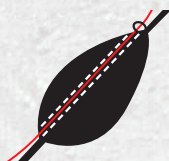

LERICI PIOMBATO

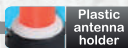

Plastic antenna holder

- PLASTIC
- POLIURETANO
- FIBERGLASS

CODE: GALER01

Size (g)	Ant. Ø	Stem. Ø	Size (g)	Ant. Ø	Stem. Ø
1,25+0,75	4,50	1,20	4,25+0,75	4,50	1,20
2,25+0,75	4,50	1,20	5,25+0,75	4,50	1,20
3,25+0,75	4,50	1,20			



TORRE PASSANTE

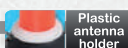

Plastic antenna holder

- PLASTIC
- POLIURETANO
- STEEL

CODE: GATOR0

Size (g)	Ant. Ø	Stem. Ø	Size (g)	Ant. Ø	Stem. Ø
1,00	4,50	0,80	4,00	4,50	1,00
1,50	4,50	0,80	5,00	4,50	1,00
2,00	4,50	0,90	6,00	4,50	1,20
3,00	4,50	0,90			



VIAREGGIO PIOMBATO

NIZZA PIOMBATO

LERICI PIOMBATO

TORRE PASSANTE



GROSSETO



PALINURO



RIMINI

NEXT
STARLITE

GROSSETO

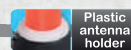
Plastic
antenna
holder

PLASTIC



POLIURETANO



FIBERGLASS

CODE: GAGRO01

Size (g)	Ant.Ø	Stem.Ø	Size (g)	Ant.Ø	Stem.Ø
0,50	3,00	1,00	1,50	3,00	1,20
0,75	3,00	1,00	2,00	3,00	1,20
1,00	3,00	1,20	3,00	3,00	1,20

PALINURO

Plastic
antenna
holder

PLASTIC



POLIURETANO



FIBERGLASS

CODE: GAPALI01

Size (g)	Ant.Ø	Stem.Ø	Size (g)	Ant.Ø	Stem.Ø	Size (g)	Ant.Ø	Stem.Ø
1,00	4,50	1,20	3,00	4,50	1,50	6,00	4,50	1,50
1,50	4,50	1,20	4,00	4,50	1,50	8,00	4,50	1,50
2,00	4,50	1,20	5,00	4,50	1,50			

RIMINI

Plastic
antenna
holder

PLASTIC



POLIURETANO



FIBERGLASS

CODE: GARIMI01

Size (g)	Ant.Ø	Stem.Ø	Size (g)	Ant.Ø	Stem.Ø	Size (g)	Ant.Ø	Stem.Ø
0,30	3,00	1,00	1,00	3,00	1,20	3,00	3,00	1,20
0,50	3,00	1,00	1,50	3,00	1,20			
0,75	3,00	1,00	2,00	3,00	1,20			

NEXT STARLITE

Plastic
antenna
holder

PLASTIC



POLIURETANO



FIBERGLASS

CODE: GANEXT01

Size (g)	Ant.Ø	Stem.Ø	Size (g)	Ant.Ø	Stem.Ø
0,20	3,00	0,80	0,75	3,00	1,00
0,30	3,00	0,80	1,00	3,00	1,00
0,50	3,00	1,00	1,50	3,00	1,00



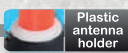

ZESTER STARLITE

- PLASTIC
- POLIURETANO
- FIBERGLASS

CODE: GAZES01

Size (g)	Ant. Ø	Stem. Ø	Size (g)	Ant. Ø	Stem. Ø	Size (g)	Ant. Ø	Stem. Ø
0,20	3,00	0,80	0,75	3,00	1,00	2,00	3,00	1,20
0,30	3,00	0,80	1,00	3,00	1,00			
0,50	3,00	1,00	1,50	3,00	1,00			

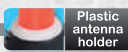

MENTA SC. STARLITE

- PLASTIC
- BALSA
- FIBERGLASS

CODE: GBMESDA

Size (g)	Ant. Ø	Stem. Ø	Size (g)	Ant. Ø	Stem. Ø
4,00	4,50	1,50	12,00	4,50	1,80
6,00	4,50	1,50	15,00	4,50	1,80
8,00	4,50	1,80	20,00	4,50	1,80
10,00	4,50	1,80	25,00	4,50	1,80
			30,00	4,50	1,80
			40,00	4,50	1,80
			50,00	4,50	1,80

NEW SIZES

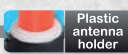

SINFLEX ANTIMURALE

- PLASTIC
- EVA

CODE: GCSINAN01

Size (g)	Ant. Ø	Stem. Ø	Size (g)	Ant. Ø	Stem. Ø	Size (g)	Ant. Ø	Stem. Ø
10,00	4,50	5,50	25,00	4,50	5,50	50,00	4,50	10,50
15,00	4,50	5,50	30,00	4,50	8,50	60,00	4,50	10,50
20,00	4,50	5,50	40,00	4,50	8,50			

ZESTER

MENTA SCORREVOLE STARLITE

SINFLEX ANTIMURALE





BALSA

SINFLEX CORBARA



SINFLEX

HOLLOW PLASTIC

FIBERGLASS

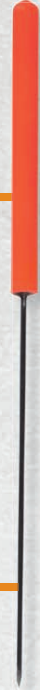

ANTENNA 1

HOLLOW PLASTIC



ANTENNA 2

BALSA



LIGHT SINFLEX + ROHACELL51

AERO RIVER

SINFLEX CORBARA

CODE: GCCOR01

Size (g)	Ant.1 ∅	Ant.2 ∅	Size (g)	Ant.1 ∅	Ant.2 ∅	Size (g)	Ant.1 ∅	Ant.2 ∅
10,00	45,00	35,00	16,00	45,00	35,00	22,00	45,00	35,00
12,00	45,00	35,00	18,00	45,00	35,00	25,00	45,00	35,00
14,00	45,00	35,00	20,00	45,00	35,00			

AERO RIVER

CODE: GCAERIVO

Size (g)	Ant.∅	Fisch.∅	Size (g)	Ant.∅	Fisch.∅
12,00	3,00	4,00	18,00	3,50	5,00
14,00	3,00	4,00	20,00	3,50	5,00
16,00	3,50	5,00	25,00	5,00	5,00
			30,00	5,00	5,00

NEW
SIZES

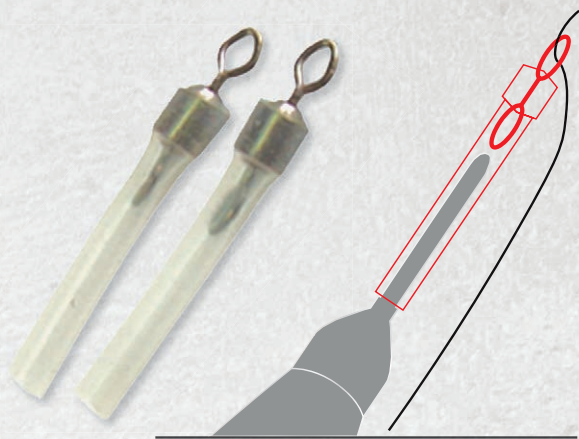

FERMA GALLEGGIANTE CON GIRELLA

FLOAT STOPPER WITH SWIVEL

Questo dispositivo consente di trasformare un galleggiante di struttura classica in un galleggiante di tipo inglese. Inserendo all'interno del tubetto in silicone la deriva di un qualunque galleggiante potremo avvalerci della tecnica english style.

This accessory allows you to transform a classically shaped float into a waggler-type float. By inserting the stem of any float into the silicone tube you can transform it to English style every time you need to. Very useful in both freshwater and sea angling.

CODE	PCS
FECO03	5



ANTENNE VUOTE

HOLLOW ANTENNAS

Antenne vuote ad alta visibilità, molto leggere e robuste. Colori giallo ed arancio fluorescente.

High visibility hollow tips, very light and strong. Fluorescent red and yellow.

CODE	diam. Ø	length	pcs	CODE	diam. Ø	length	pcs
ANT1247	Ø 1,20	47	5	ANT3565	Ø 3,50	65	5
ANT1555	Ø 1,50	55	5	ANT3580	Ø 3,50	80	5
ANT1855	Ø 1,80	55	5	ANT4065	Ø 4,00	65	5
ANT2055	Ø 2,00	55	5	ANT4080	Ø 4,00	80	5
ANT2560	Ø 2,50	60	5	ANT4590	Ø 4,50	90	5
ANT3065	Ø 3,00	65	5				
ANT3070	Ø 3,00	70	5				

FISCHIONE

FISCHIONE

CODE	sizes	pcs
ANT5000	Ø 6,0mm / Ø 8,0mm	4

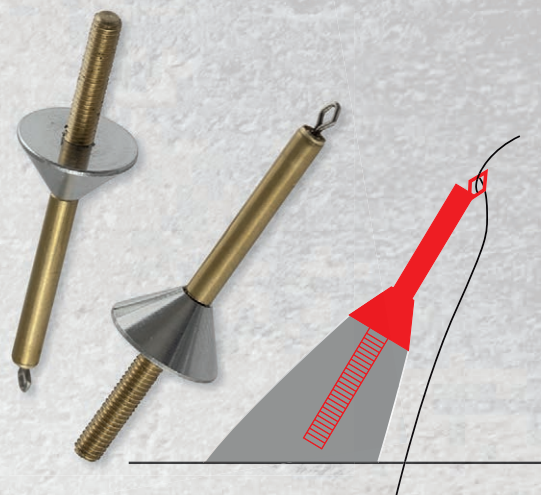
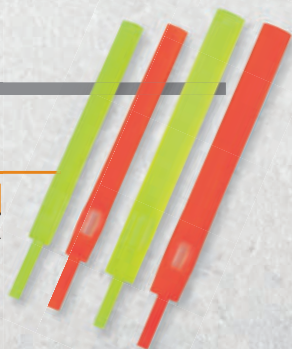

TESTE ALLUMINIO

ALUMINIUM HEADS

Queste testine di alluminio, sono state ideate e realizzate per rendere un qualsiasi galleggiante inglese con rondelle, un galleggiante a scorrere che porti sulla lenza grammature sostenute. Infatti togliendo la testa piombata del nostro galleggiante e inserendo questa testina di alluminio, possiamo ottenere le solite caratteristiche di un classico galleggiante inglese.

These heads in aluminium have been designed and produced to transform any waggler with rings into a running float that can carry even significant weights on the line. By removing the weighted head of the waggler and replacing it with this aluminium head, you can obtain all the classical features of a waggler designed specifically for English-style fishing.

CODE	sizes	pcs
GCZZ1	Ø 10mm	2
GCZZ3	Ø 12mm	2

ANTENNE VUOTE

HOLLOW ANTENNAS

Antenne vuote di ricambio, per galleggianti Inglesi VICTORY e STRALE BREAM. Il massimo come leggerezza e visibilità. Confezioni da 4 pezzi.

Hollow spare tips for VICTORY and STRALE BREAM match floats. The last word in lightness and visibility. 4-piece pack.

CODE	pcs
ANT5002	4



FISCHIONE

FISCHIONE

Confezione assortita di un fischione per diametro colore giallo e rosso.

Diam. 4,00 - 4,80 - 6,50.

Assorted pack including one hollow tip per diameter in red and yellow colour.

Diam. 4.00 - 4.80 - 6.50mm.

CODE	pcs
ANT5003	6



2018

NEW

COLMIC

8

ABBIGLIAMENTO \ CLOTHING

www.colmic.it

COLMIC

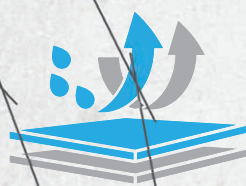
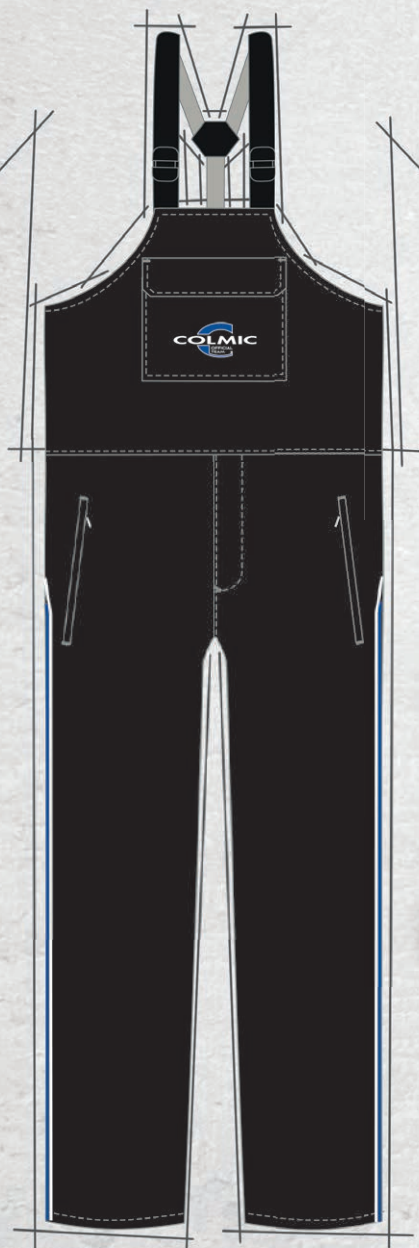
OFFICIAL
TEAMWATER
& WIND
RESISTANT

CODE	Sizes
ABG010A	S
ABG010B	M
ABG010C	L
ABG010D	XL
ABG010E	2XL
ABG010F	3XL

POLAR OFFICIAL TEAM



Il completo Polar Official Team è costituito da giacca e salopette realizzato in RIP STOP COATED WATERPROOF con cuciture termosaldate. La giacca è realizzata con una ampia e soffice imbottitura che garantisce calore e freschezza ed è dotata di cappuccio removibile a zip. La salopette anch'essa imbottita in soffice materiale traspirante, con bretelle elastiche, ci permette di assecondare i nostri movimenti in fase di pesca in tutta libertà.

The Polar Official Team suit is composed by a jacket and a salopette made of RIP STOP COATED WATERPROOF fabric featuring thermo welding sewing. The jacket features a ample and soft breathable micro fleece lining and a removable hood. The salopette features a breathable lining, the elastic suspenders will allow us to move comfortably during the fishing action.

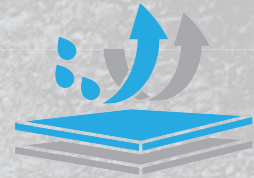

**WATER
& WIND
RESISTANT**

GIACCA LONDON LONDON JAKET



Questo capo di abbigliamento impermeabile, leggero e confortevole, realizzato in 320D Tason con spalmatura in poliuretano (100% nylon) ed interno 100% poliestere, può essere usato in qualsiasi occasione, comprese le giornate di forte vento e pioggia, consentendo al pescasportivo di rimanere sempre caldo e asciutto.

This waterproof clothing, light and comfortable, made in 320D Tason with polyurethane coating (100% nylon) and a 100% polyester lining, can be used on any occasion, even on days of strong wind and rain, allowing the angler to keep warm and dry. These are the reasons why Colmic has come up with the proposal of these new jackets, which differ from each other in terms of style.

CODE	Sizes
ABG011A	S
ABG011B	M
ABG011C	L
ABG011D	XL
ABG011E	2XL
ABG011F	3XL



GIACCA OXFORD OXFORD JAKET



Giacca leggera, morbida e confortevole è realizzata con un tessuto antivento e un'imbottitura interna che mantiene perfettamente la temperatura corporea. Dotata di cappuccio e 2 tasche esterne è perfetta sia per la pesca che per il tempo libero.

Light jacket, soft and comfortable, made out of a windproof fabric and with an internal lining which keeps body temperature perfectly. Including a hood and external 2 pockets, it is perfect for fishing as well as for casual wear.

CODE	Sizes
ABG012B	M
ABG012C	L
ABG012D	XL
ABG012E	2XL
ABG012F	3XL



2018

NEW

COLMIC

81

ABBIGLIAMENTO \ CLOTHING

www.colmic.it

NEW ZEALAND OFFICIAL TEAM



Calda e morbida felpa realizzata in cotone 35% e poliestere 65% con cappuccio a protezione avvolgente con il quale possiamo ripararci completamente dal freddo e dal vento. Logo Colmic pettorale, cerniera lampo intera e finiture bianco/blu, donano a questa felpa un look e un design davvero accattivante.

Warm and soft fleece made out of 35% cotton and 65% polyester, having a hood with enveloping protection with which we can shelter ourselves completely from the cold and the wind. Breast Colmic Logo, whole length zipper and white/blue finish, impart a really captivating look and design.

CODE	Sizes
ABF010A	S
ABF010B	M
ABF010C	L
ABF010D	XL
ABF010E	2XL
ABF010F	3XL



UNIVERSAL OFFICIAL TEAM



Felpa studiata e creata per le stagioni autunnali e primaverili, dove è necessario indossare un capo che non sia troppo pesante. Realizzata in cotone 35% e poliestere 65%, morbida e leggera, si presta egregiamente per le nostre uscite di pesca e per il tempo libero in generale.

This jumper has been developed for spring and fall weather, where a medium weight cloth is required. Made of 35% cotton and 65% polyester, soft and lightweight, perfect for our fishing outings or as a casual dress.

CODE	Sizes
ABF011A	S
ABF011B	M
ABF011C	L
ABF011D	XL
ABF011E	2XL
ABF011F	3XL



COLMIC
OFFICIAL
TEAM



PILE OFFICIAL TEAM OFFICIAL TEAM PILE



Maglione in pile 340g con trattamento "Anti Peeling". Caldo, morbido e dal design accattivante, il Pile OFFICIAL TEAM è stato curato in ogni suo più piccolo dettaglio per renderlo versatile e pratico allo stesso tempo.

Made of pile 340g with "Anti Peeling" treatment. This warm and soft, nice design OFFICIAL TEAM fleece jacket is perfect in all details, versatile and practical at the same time.

CODE	Sizes
ABF012A	S
ABF012B	M
ABF012C	L
ABF012D	XL
ABF012E	2XL
ABF012F	3XL



MICROPILE OFFICIAL TEAM



Capo in morbida e calda fibra "MicroPile 100%" 220g. Versatile e comodo, questo micropile può essere indossato sotto ad una giacca o ad un pile per mantenere un'ulteriore strato termico nelle più fredde giornate invernali.

100% "Micro fleece" 220g shirt. This comfortable and versatile micro fleece shirt can be worn under a jacket or a heavier fleece jacket to add a layering for the coldest winter day out.

CODE	Sizes
ABF013A	S
ABF013B	M
ABF013C	L
ABF013D	XL
ABF013E	2XL
ABF013F	3XL



2018

NEW

COLMIC

83

ABBIGLIAMENTO \ CLOTHING

www.colmic.it



POLO OFFICIAL TEAM OFFICIAL TEAM POLO SHIRT



Polo 100% cotone personalizzata con logo Colmic pettorale piccolo e logo posteriore grande.

Polo shirt 100% Cotton fabric T-shirt featuring a small Colmic chest logo and large rear logo.

CODE	Sizes
ABT013A	S
ABT013B	M
ABT013C	L
ABT013D	XL
ABT013E	2XL
ABT013F	3XL



POLO (WHITE & BLUE) POLO SHIRT



Polo 100% cotone personalizzata con logo Colmic pettorale piccolo e logo posteriore grande.

Polo shirt 100% Cotton fabric T-shirt featuring a small Colmic chest logo and large rear logo.

CODE	Sizes
ABT014A	S
ABT014B	M
ABT014C	L
ABT014D	XL
ABT014E	2XL
ABT014F	3XL



T-SHIRT COLMIC BLUE & WHITE-BLUE



T/Shirt 100% cotone personalizzata con logo Colmic pettorale piccolo e logo posteriore grande.

100% Cotton fabric T-shirt featuring a small Colmic chest logo and large rear logo.

BLUE

CODE	Sizes
ABT010A	S
ABT010B	M
ABT010C	L
ABT010D	XL
ABT010E	2XL
ABT010F	3XL

WHITE - BLUE

CODE	Sizes
ABT011A	S
ABT011B	M
ABT011C	L
ABT011D	XL
ABT011E	2XL
ABT011F	3XL



T-SHIRT COLMIC YOUNG ONE SIZE



T/Shirt 100% cotone per i bambini. 100% Cotton fabric T-shirt for children.

CODE	Sizes
ABT012A	XS

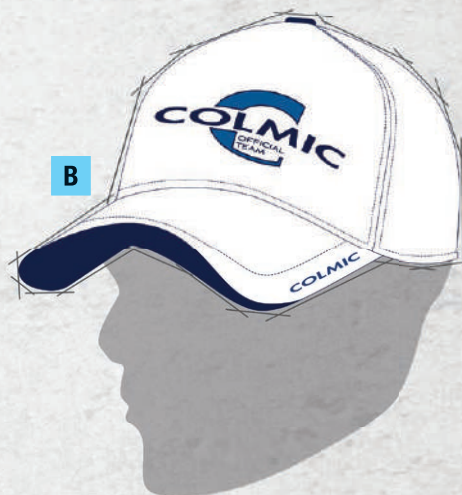

CAPPELLI COLMIC COLMIC CAP

CODE	DESCRIPTION
A CLC60A	CAPPELLO IN COTONE BLU - BLUE COTTON CAP
B CLC60B	CAPPELLO IN COTONE BIANCO - WHITECOTTON CAP
C CLC61A	CAPPELLO BLU BIANCO C/RETE - BLUE WHITE MASH CAP
D CLC62A	VISIERA COLMIC - COLMIC HEAD VISOR
E CLC60A1	CAPPELLO IN COTONE BLU + LED - BLUE COTTON CAP + LED

OFFICIAL TEAM

COLMIC

SUPERIOR CLASS

LISBONA SERIES

La serie di borse semirigide SUPERIOR BAGS, da noi proposta in quattro diverse misure, è stata oggetto di studio e ricerca per quanto concerne funzionalità e nuovi materiali. Questi prodotti sono stati realizzati in materiale (synthetic leather) antistrappo ed antiusura. Disegnate in stile 1K carbon, l'interno delle borse è rivestito da una imbottitura in tessuto con all'interno una membrana la quale, oltre che a proteggere i nostri accessori da urti accidentali, risulta anche essere un ottimo isolante termico. Le borse SUPERIOR BAG sono quanto di meglio si possa reperire sul mercato e sono adatte a contenere materiali di qualunque genere. Mantengono al fresco vettovaglie ed esche, e tengono all'asciutto indumenti, mulinelli, nylon e qualsiasi altro oggetto per la pesca. Realizzate nella classica colorazione Colmic, sono tutte dotate di pratiche maniglie, di cinghia per tracolla e di chiusura ermetica a zip. Le nuove borse Colmic SUPERIOR BAG non sono soltanto belle esteticamente, ma sono anche tra le più robuste e le più durevoli attualmente disponibili in commercio.

This range of semi-rigid SUPERIOR BAGS has been studied to grant a high functionality and durability. It is made of a special anti-tear and anti-wear synthetic leather. Designed in a 1K carbon style, the inside of the bags is covered with a padding that contains a membrane which protects our accessories from accidental bumps and works as an excellent thermal insulator. The SUPERIOR BAGS are the best one can find on the market and are suitable for containing any kind of material. They keep baits cool, they keep garments, reels, nylon and any other fishing tackle in dry conditions. They all features practical handles, shoulder straps and zippered closure. The new Colmic SUPERIOR BAG bags are not only beautiful, but are also the most durable ones currently available on the market.



CODE	ITEM
BO1001A	LISBONA S

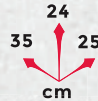

CODE	ITEM
BO1001B	LISBONA M

**HIGH QUALITY
HIGH PERFORMANCE**

**WATERPROOF
MATERIAL**

**HIGH QUALITY
SEAMS**



CODE	ITEM
BO1001C	LISBONA L

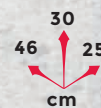

CODE	ITEM
BO1001D	LISBONA XL



**INTERNAL
PADDED**

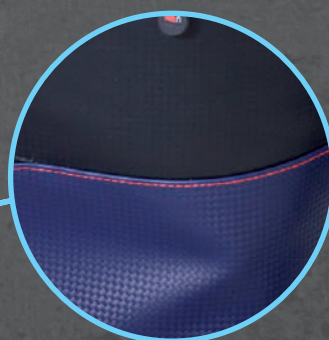

**HI-TECH
MATERIAL**

2018

NEW

COLMIC

87

BORSETTERIA \ LUGGAGE

www.colmic.it

PVC COLMIC

EXTREME COMPETITION - OFFICIAL TEAM

ORANGE SERIES

SALDATURE A TENUTA STAGNA CERNIERATI ANTICORROSIONE WATERPROOF

- Preserva gli ambienti dai cattivi odori
- Evita perdite liquide residue
- Leggero
- Indistruttibile
- Ripiegabile salva spazio

WATERTIGHT WELDING ANTI CORROSION WATERPROOF ZIPPERS

- Protects the surroundings from bad smells
- Prevents liquid seepage
- Light
- Indestructible
- Can be folded to save space



PANTERA SERIES

Dotato di maniglie ergonomiche rigide in plastica e di tracolla, consente una facilità di trasporto unica; la chiusura con cerniera che funge da coperchio semi rigido, permette una rapida collocazione dei materiali al suo interno.

Equipped with stiff ergonomic handles in plastic and shoulder strap for a genuinely unique ease of transport. The zipper closure that also functions as a semi-stiff lid, makes it easy to stow your gear inside.

CODE	Item	SIZES
BOXEVA309A	PANTERA M	55cm x 13cm x h.50cm
BOXEVA309B	PANTERA L	65cm x 17cm x h.60cm
BOXEVA309C	PANTERA XL	65cm x 25cm x h.62cm

PUMA SERIES

Viene proposto in versione quadrata e circolare, ed in 2 diverse misure per ognuna di queste forme.

Puma is offered in a squared and in a round version in 2 sizes each model.

CODE	ITEM	SIZES
BOXEVA310A	PUMA SQUARED	60cm x 15cm x h. 60cm
BOXEVA310B	PUMA ROUND	Ø 60cm x 15cm



JAGUAR SERIES

Questa innovativa borsa rigida in PVC, è molto pratica ed eclettica. La possibilità di dividere l'oggetto in due parti distinte e utilizzabili indipendentemente l'una dall'altra, la rende adattabile a qualsiasi necessità di trasporto e di pesca. La borsa, proposta in due diverse misure, sono entrambe isolate termicamente da una lamina interna di materiale coibentante. Le due parti si prestano ad essere utilizzate per riporre qualsiasi oggetto: minuteria, scatolame, vestiario, nylon, esche vive, mulinelli, bobine ed altro ancora.

This innovative hard bag in PVC is extremely practical and eclectic. The possibility of dividing the bag into two completely separate parts that can be used independently means that it can be adapted to any transport and fishing requirement. Proposed in two different sizes, the bag is thermally insulated by an inner layer of insulating material. Both parts can be used for stowing away any object at all: small fishing accessories, tins and boxes, clothes, nylons, live bait, reels, spools and practically anything else you can imagine.

CODE	ITEM	SIZES
BOXEVA308A	JAGUAR SMALL	36cm x 25cm x h.13cm + 36cm x 25cm x h.23cm
BOXEVA308B	JAGUAR BIG	50cm x 28cm x h.15cm + 50cm x 28cm x h.28cm



LION SERIES

Le maniglie ergonomiche in materiale plastico sono una delle peculiarità principali di questo articolo che può esser utilizzato per varie finalità.

The ergonomic plastic handles are one of the main features of this interesting article, which can be used for a variety of different functions.

CODE	ITEM	SIZES
BOXEVA307A	LION SMALL	30cm x 22cm x h.22cm
BOXEVA307B	LION MEDIUM	39cm x 24cm x h. 26cm
BOXEVA307C	LION BIG	45cm x 29cm x h. 30cm



KANGURO SERIES

La KANGURO, vi consentirà di tenere ben in ordine le lenze già pronte e avvolte sulle stecche, le bobine dei mulinelli, fionde, minuterie varie, nylon, bobine, galleggianti e molto altro, preservando sempre il tutto dalle intemperie e dai raggi del sole.

The KANGURO will allow you to keep already wound lines, reel spools, catapults, sundry small accessories, nylons, spools, floats and much more besides in perfect order, while also protecting them from bad weather and from sunlight.

CODE	ITEM	SIZES
BOXEVA303A	KANGURO X12	35cm x 12cm x h.9cm
BOXEVA303B	KANGURO X16	35cm x 16cm x h.9cm
BOXEVA303C	KANGURO X20	35cm x 20cm x h.11cm
BOXEVA303D	KANGURO X24	35cm x 24cm x h.11cm



WALLABY SERIES

Comode porta fionde realizzate in PVC impermeabile.

Comfortable sling pouch in waterproof PVC.

CODE	ITEM	SIZES
BOXEVA313A	WALLABY GROUND BAIT	20cm x 25cm x h.14cm
BOXEVA313B	WALLABY FISHERIES	18cm x 21cm x h. 10cm

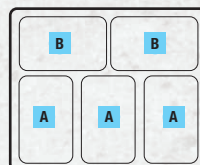

A code:SC10B B code:SC10A
BAIT BOXES NOT INCLUDED

BAIT BOX HOLDER

Contenitore rettangolare in PVC impermeabile, dotato di coperchio e maniglia, ideale per riporre ogni tipo di oggetto. Studiato per riporre 3 BAIT BOX da 0,60l + 2 BAIT BOX da 0,30l.

Rectangular container in waterproof PVC, equipped with cover and handle, ideal for storing any kind of object. Designed for containing 3 BAIT BOXES of 0,60l + 2 BAIT BOXES of 0,30l.

CODE	ITEM	SIZES
BOXEVA512	BAIT BOX HOLDER	32,5cm x 26,5cm x h.6,5cm



KOALA

Il KOALA è un secchiello quadrato in PVC, con supporto in metallo da agganciare alla cintura o sull'orlo degli waders, studiato appositamente per contenere esche di qualsiasi tipo e preservarle sempre ben asciutte.

The KOALA is a square bucket made of PVC, with a metal brace that you can attach to your belt or to the top of your waders. It is specially designed to hold bait of all kinds and keep them nice and dry.

CODE	ITEM	SIZES
BOXEVA302	KOALA	20cm x 20cm x h.20cm



BAIT BOX ISTRICE

Contenitore porta esche in PVC impermeabile, dotato di gancio per cintura, ha un design studiato per aderire sia alla vita che alla gamba del pescatore.

Bait box in waterproof PVC, equipped with a hook for the belt, it is designed for clinging both to the fisherman's rear or leg.

CODE	ITEM	SIZES
BOXEVA304	BAIT BOX ISTRICE	28cm x 19cm x h.16cm

MOBY

Il pratico cordino del quale è dotato, permette di raccogliere l'acqua anche da altezze considerevoli, con estrema facilità; quindi risulta ideale per la pesca agonistica, in scogliera, per la pesca dalla spiaggia o semplicemente da tenere in barca.

The practical cord makes it possible to collect water very easily even from considerable heights; it is consequently perfect for competition fishing, for fishing from rocks or from the beach, or simply just to use on a boat.

CODE	ITEM	SIZES
BOXEVA301	MOBY	20cm x 20cm x h.20,5cm



CEFALO SERIES

Questa linea di pratici secchi porta vivo in PVC, si è rivelata molto valida e funzionale. Il contenitore standard, ha una tasca laterale per l'ossigenatore a pile ed un coperchio trasparente con cerniera, mentre quello con rete, ha questa soluzione collocata proprio sotto il coperchio trasparente, la quale impedisce totalmente al vivo di fuoriuscire. Il colore bianco di questi secchielli, è stato scelto appositamente per una più rapida individuazione delle esche vive all'interno del contenitore stesso.

This range of practical live bait buckets in PVC has proved to be extremely valid and practical. The standard container has a side pocket for the battery-operated oxygenator and a transparent lid with zipper, whereas the mesh version features a mesh placed just beneath the plastic lid, as a total guarantee that the live bait cannot get out. The white colour was chosen specifically for these accessories to make it easier to identify the live bait inside the container.

CODE	ITEM	SIZES
BOXEVA305	CEFALO	27cm x h. 24cm
BOXEVA306	CEFALO C/RETE	33cm x h. 23cm



ACQUARIO

La borsa ACQUARIO è completamente stagna e il suo compito primario è quello di contenere il pescato, senza che questo vada a sporcare l'imbarcazione e senza che nessuno possa vedere il contenuto della borsa stessa, al momento dello sbarco... Utile anche a contenere indumenti e stivaleria ancora umidi, da far asciugare con calma al momento del rientro a casa.

The ACQUARIO is completely watertight, its primary function being to hold the catch, and prevent the fish from dirtying the boat (and also preventing anyone from seeing the contents of the bag during the landing phase). It is also perfect for holding clothes and boots that are still wet, which you can then dry out at leisure once you're back home.

CODE	ITEM	SIZES
BOXEVA311	ACQUARIO XL	160cm x h.63cm

WEPER X4

Weper X4 è un tracciato All Round ad alto profilo tecnico, sviluppato per tutte le tecniche di pesca offre un ampio range di diametri. La geometria di trecciatura (HD ROUND SHAPE) e il mix di polimeri di resinatura (HT POLYMIX), massimizzano ed esaltano le proprietà fisico-chimiche di questa nuova fibra dalle caratteristiche straordinarie. L'HIGH-GRADE PE, evoluzione tecnica del PE, trasforma l'azione di pesca in un'esperienza unica. I trattamenti di finissaggio in MICROWAX creano una barriera protettiva che fa scivolare la treccia sugli ostacoli riducendo drasticamente le rotture per abrasione e contribuendo a raddoppiare la vita del prodotto. Il processo di stiratura HPT ad alta pressione e temperatura, orienta le molecole della fibra incrementando del 20% il carico di rottura, spingendo il DC-RATIO (rapporto diametro/carico) a livelli prima impensabili.

Weper X4 is a high technical profile braided line suitable for many different kinds of fishing techniques and available in a big range of diameters. The braiding geometry (HD ROUND SHAPE) and the mix of resin polymers (HT POLYMIX) will maximize and exalt the physical and chemical features of this new extraordinary fiber. The HIGH GRADE PE, the technical evolution of the PE, will transform the fishing action in a unique experience. The MICROWAX finishing permeating the braid will protect it from abrasions and will help it to slide on obstacles and snags increasing the braid life. The high pressure and temperature HTP pre stretching treatment will orientate the fibers molecules increasing the knot strength of 20% and pushing the DC-RATIO to diameter/strength ratio never reached before.



WEPER X8

Weper X8 rappresenta la massima espressione nel campo dei trecciati. La geometria di trecciatura (HD ROUND SHAPE) e il mix di polimeri di resinatura (HT POLYMIX), massimizzano ed esaltano le proprietà fisico-chimiche di questa nuova fibra dalle caratteristiche straordinarie. L'HIGH-GRADE PE, evoluzione tecnica del PE, trasforma l'azione di pesca in un'esperienza unica. Il profilo rotondo e la mano liscia e setosa (SILK TECHNOLOGY) garantiscono lanci più lunghi mentre il processo di stiratura HPT ad alta pressione e temperatura, orienta le molecole della fibra incrementando del 20% il carico di rottura e spingendo il rapporto diametro/carico (DC-RATIO) a livelli prima impensabili. I trattamenti di finissaggio in MICROWAX creano una barriera protettiva che fa scivolare la treccia sugli ostacoli riducendo le rotture per abrasione e contribuendo a raddoppiare la vita del prodotto.

Weper X8 is the latest technologies expression in the braided lines market. The braiding geometry (HD ROUND SHAPE) and the mix of resin polymers (HT POLYMIX) will maximize and exalt the physical and chemical features of this new extraordinary fiber. The HIGH GRADE PE, the technical evolution of the PE, will transform the fishing action in a unique experience. The round shape and the new silky coating (SILK TECHNOLOGY) will guarantee longer casts, the high pressure and temperature HTP pre stretching treatment will orientate the fibers molecules increasing the knot strength of 20% and pushing the DC-RATIO diameters/strength ratio at a level never achieved before. The MICROWAX finishing permeating the braid will protect it from abrasions and will help it to slide on obstacles and snags increasing the braid life.

BRAIDED



ORANGE

CODE 100yds	LBS	MM	kg	PE
NYWEX44105	5	0,04	2,3	0,05
CODE 150yds	LBS	MM	kg	PE
NYWEX4407	7	0,05	3,2	0,10
NYWEX4410	10	0,06	4,5	0,15
NYWEX4412	12	0,08	5,4	0,20
NYWEX4416	16	0,10	7,2	0,40
NYWEX4420	20	0,125	9	0,60
NYWEX4425	25	0,16	10,5	1,00
NYWEX4433	33	0,20	15	1,50
NYWEX4445	45	0,25	20,4	2,30
NYWEX4460	60	0,35	27,2	4,50
NYWEX4480	80	0,45	36,3	7,50
NYWEX4499	100	0,55	45,5	11,00
CODE 300yds	LBS	MM	kg	PE
NYWEX4516	16	0,10	7,2	0,40
NYWEX4520	20	0,125	9	0,60
NYWEX4525	25	0,16	10,5	1,00
NYWEX4533	33	0,20	15	1,50
NYWEX4545	45	0,25	20,4	2,30
NYWEX4560	60	0,35	27,2	4,50
NYWEX4580	80	0,45	36,3	7,50
NYWEX4599	100	0,55	45,5	11,00
CODE 1000yds	LBS	MM	kg	PE
NYWEX4660	60	0,35	27,2	4,50
NYWEX4680	80	0,45	36,3	7,50
NYWEX4699	100	0,55	45,5	11,00

GREY

CODE 100yds	LBS	MM	kg	PE
NYWEX4105	5	0,04	2,3	0,05
NYWEX4107	7	0,05	3,2	0,10
NYWEX4110	10	0,06	4,5	0,15
NYWEX4112	12	0,08	5,4	0,20
NYWEX4116	16	0,10	7,2	0,40
CODE 150yds	LBS	MM	kg	PE
NYWEX4210	10	0,06	4,5	0,15
NYWEX4212	12	0,08	5,4	0,20
NYWEX4216	16	0,10	7,2	0,40
NYWEX4220	20	0,125	9	0,60
NYWEX4225	25	0,16	10,5	1,00
NYWEX4233	33	0,20	15	1,50
NYWEX4245	45	0,25	20,4	2,30
NYWEX4260	60	0,35	27,2	4,50
NYWEX4280	80	0,45	36,3	7,50
NYWEX4299	100	0,55	45,5	11,00
CODE 300yds	LBS	MM	kg	PE
NYWEX4316	16	0,10	7,2	0,40
NYWEX4320	20	0,125	9	0,60
NYWEX4325	25	0,16	10,5	1,00
NYWEX4333	33	0,20	15	1,50
NYWEX4345	45	0,25	20,4	2,30
NYWEX4360	60	0,35	27,2	4,50
NYWEX4380	80	0,45	36,3	7,50
NYWEX4399	100	0,55	45,5	11,00

WEPER X8

ORANGE

CODE 150yds	LBS	MM	kg	PE
NYWEX8415	15	0,09	7	0,35
NYWEX8421	21	0,125	9,5	0,60
NYWEX8425	25	0,16	11,4	1,00
NYWEX8430	30	0,20	13,6	1,50
NYWEX8440	40	0,25	18,2	2,30
NYWEX8450	50	0,30	22,7	3,40
NYWEX8465	65	0,35	29,5	4,50
NYWEX8480	80	0,40	36,3	6,00
CODE 300yds	LBS	MM	kg	PE
NYWEX8521	21	0,125	9,5	0,60
NYWEX8525	25	0,16	11,4	1,00
NYWEX8530	30	0,20	13,6	1,50
NYWEX8540	40	0,25	18,2	2,30
NYWEX8550	50	0,30	22,7	3,40
NYWEX8565	65	0,35	29,5	4,50
NYWEX8580	80	0,40	36,3	6,00

GREY

CODE 100yds	LBS	MM	kg	PE
NYWEX8115	15	0,09	7	0,35
NYWEX8121	21	0,125	9,5	0,60
CODE 150yds	LBS	MM	kg	PE
NYWEX8215	15	0,09	7	0,35
NYWEX8221	21	0,125	9,5	0,60
NYWEX8225	25	0,16	11,4	1,00
NYWEX8230	30	0,20	13,6	1,50
NYWEX8240	40	0,25	18,2	2,30
NYWEX8250	50	0,30	22,7	3,40
NYWEX8265	65	0,35	29,5	4,50
NYWEX8280	80	0,40	36,3	6,00
CODE 300yds	LBS	MM	kg	PE
NYWEX8315	15	0,09	7	0,35
NYWEX8321	21	0,125	9,5	0,60
NYWEX8325	25	0,16	11,4	1,00
NYWEX8330	30	0,20	13,6	1,50
NYWEX8340	40	0,25	18,2	2,30
NYWEX8350	50	0,30	22,7	3,40
NYWEX8365	65	0,35	29,5	4,50
NYWEX8380	80	0,40	36,3	6,00

Seaguar

FLUOROCARBON 100X100

2018

NEW

COLMIC

93

FILI \ LINES

www.colmic.it



SECOL

L'azienda giapponese SEAGUAR, leader nella produzione di Fluorocarbon, studia e si rinnova costantemente grazie all'ausilio di un team di esperti e di nuove tecnologie sempre all'avanguardia, offrendo al mercato prodotti unici nel suo genere. Nasce così SECOL un fluorocarbon di nuova generazione.

- INVISIBILITÀ IN ACQUA SENZA PARAGONI;
- ESISTENZA ALL'ABRASIONE MAI VISTA PRIMA;
- STRABILIANTE TENUTA AL NODO;
- INEGUAGLIABILE NEL CONFERIRE ALL'ESCA MOVIMENTI NATURALI;

Quattro caratteristiche essenziali, 4 punti forza straordinari!!!

The Japanese SEAGUAR company, leader in manufacture of fluorocarbons, has been constantly researching and improving its products, thanks to a team of experts and new technologies that are always at the avant-garde. The result is an offer of products unique in their genre as to quality. So, SECOL, a new generation fluorocarbon was born.

- INVISIBILITY IN WATER WITH NO COMPARISONESISTENZA;
 - NEVER EXPERIENCED RESISTANCE TO ABRAHASION;
 - ASTONISHING KNOTH STRENGTH;
 - IT GIVES TO THE BAIT A VERY NATURAL MOVEMENT;
- Four main features, 4 exceptional points of strength!

POWER-F

CODE 30m	Diameter (mm)	Kg	Lb
NYSC620	0,620	28	61,8
NYSC740	0,740	36	79,5

CODE 50m	Diameter (mm)	Kg	Lb
NYSC104	0,104	1,10	2,4
NYSC117	0,117	1,35	3
NYSC128	0,128	1,80	4
NYSC148	0,148	2,40	5,3
NYSC165	0,165	3	6,6
NYSC185	0,185	3,50	7,7
NYSC205	0,205	4,50	9,9
NYSC235	0,235	6	13,3
NYSC260	0,260	7	15,5
NYSC285	0,285	8	18
NYSC330	0,330	10	22
NYSC370	0,370	12	26
NYSC405	0,405	13	28,7
NYSC435	0,435	15	33,1
NYSC470	0,470	17	37,5
NYSC520	0,520	22	48,6

MATCH

CODE 50m	Diameter (mm)	Kg	Lb
NYSCM10	0,104	1,20	2,65
NYSCM11	0,117	1,50	3,30
NYSCM12	0,128	2,00	4,40
NYSCM14	0,148	2,60	5,75
NYSCM16	0,165	3,20	7,10
NYSCM18	0,185	3,70	8,20
NYSCM20	0,205	4,80	10,60
NYSCM23	0,235	6,40	14,10

2018

ONE 2.0 LIMITED EDITION

NEW

COLMIC

94

PANIERI \ SEATBOXES



ONE 2.0 RED
code:PA0802



**HIGH QUALITY
HIGH PERFORMANCE**

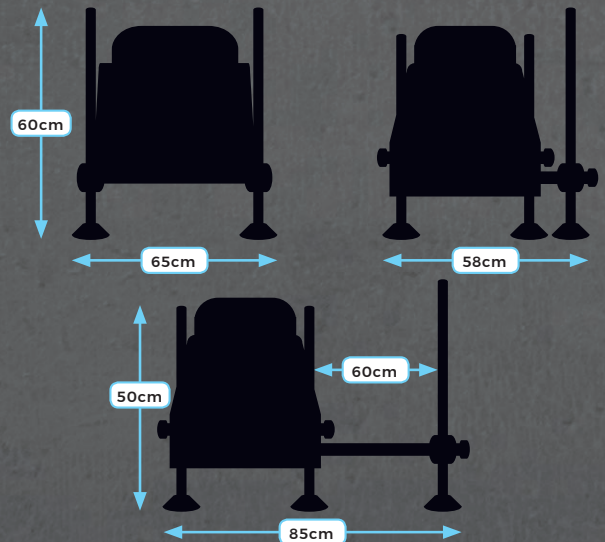



ONE 2.0 BLUE
code:PA0803

ONE 2.0

LIMITED EDITION

- 1 Seduta Anatomica 2.0.
- 1 Modulo HI-Tech: 2 cassetti forntali con ribalta portalenze. 42x32cm H.5cm (cassetti: 29,5x18cm H.3.5).
- 1 Modulo HI-Tech Porta-Lenze 42x32cm H.3,5cm.
- 1 Valigetta con Modulo HI-Tech Porta-Lenze (42x32cm H.3,5cm).
- 4 Gambe Telescopiche H.50cm Ø30mm.
- 2 Gambe Pedana Telescopiche H. 60cm Ø30mm.
- 1 Piatto Laterale Techno Form 300 (37cm x 50cm).
- 1 Paletto Porta-Nassa.
- 2 Appoggia-Canne Laterali.
- 1 Porta Ombrello "Long".
- 1 Tracolla Imbottita Ergonomica.
- 1 Barra Frontale inclinabile
- 14 Stecche portalenze

- 1 Anatomic seat 2.0.
- 1 HI-Tech module: 2 frontal drawers + line winder tray 42x32cm H.5cm (drawers: 29,5x18cm H.3.5).
- 1 HI-Tech Module: Line winder tray 42x32cm H.3,5cm.
- 1 Sliding Case with HI-Tech Module: Line winder tray (42x32cm H.3,5cm).
- 4 Telescopic legs H.50cm Ø30mm.
- 2 Footplate telescopic legs H. 60cm Ø30mm.
- 1 Side tray Techno Form 300 (37cm x 50cm).
- 1 Keep net holder .
- 2 Lateral rod holders
- 1 Umbrella holder "Long".
- 1 Ergonomic padded shoulder strap
- 1 Inclinable frontal Bar F
- 14 Line winders



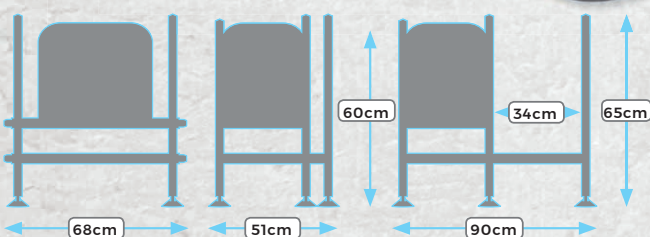

HURRICANE PRO

code:PA10200

- Seduta Anatomica con rivestimento in pelle Simil-Carbonio
- 1 Cassetto Laterale 25x39cm H.3,50cm
- 2 Cassetti Frontali 17x27cm H.3,50cm
- 1 Moduli Porta-Lenze H.3,5cm
- 2 Gambe Posteriori Telescopiche H. 60cm Ø30mm
- 2 Gambe Anteriori Telescopiche H. 65cm Ø30mm
- 2 Gambe Pedana Telescopiche H. 65cm Ø30mm
- Piatto Laterale 41x32cm
- Paletto Porta-Nassa su Pedana
- Tracolla Imbottita Ergonomica
- Livella Frontale + Livella Laterale

- Anatomic seat with carbon look leather cover
- 1 Lateral drawer 25x39cm H.3.5cm
- 2 Front drawers 17x27cm H.3.5cm
- 1 Rig Holder compartments H.3.5cm
- 2 Telescopic back legs H.60cm Ø30mm
- 2 Telescopic front legs H.65cm Ø30mm
- 2 Footplate telescopic legs H.65cm Ø30mm
- 1 Side tray 41x32cm
- 1 Keep net holder on the footplate
- Ergonomic padded shoulder strap
- 1 Front and 1 Lateral level



SERIES



6,2 kg

Ø 30mm

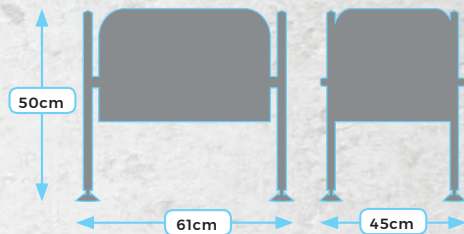

IROS SPECIAL 500

code:PA10100D

- Seduta con rivestimento in pelle Simil-Carbonio
- 1 Modulo 2 Cassetti Frontali 17x27cm H.3,50cm
- 1 Modulo Porta-Lenze H.3,5cm
- 1 Vano Portaoggetti H.16cm
- 4 Gambe Fisse H. 50cm Ø30mm
- Tracolla Imbottita Ergonomica
- Livella Frontale
- Seat with carbon look leather cover
- 1 Module 2 Front drawers 27cmx17cm h.35mm
- 1 Upper rig holder compartment 3,5cm
- 1 Accessory's storage h.16cm
- 4 Gambe Fisse H. 50cm Ø30mm
- Shoulder strap for transport
- 1 Frontal level



4,9 kg

Ø 30mm

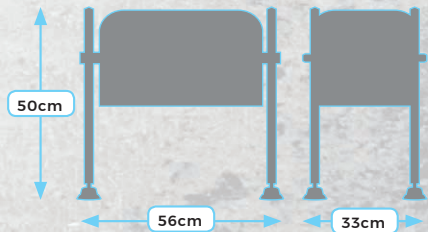

IROS SPECIAL 300

code:PA10100C

- Seduta con rivestimento in pelle Simil-Carbonio
- 1 Modulo Porta-Lenze H.3,5cm
- 1 Vano Portaoggetti H.16cm
- 4 Gambe Fisse H. 50cm Ø30mm
- Tracolla Imbottita Ergonomica
- Livella Frontale
- Seat with carbon look leather cover
- 1 Upper rig holder compartment 3,5cm
- 1 Accessory's storage h.16cm
- 4 Gambe Fisse H. 50cm Ø30mm
- Shoulder strap for transport
- 1 Frontal level

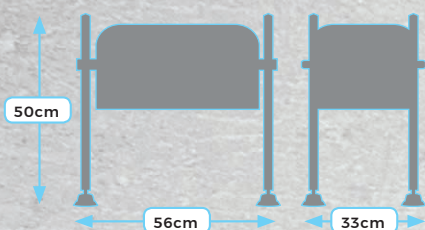

IROS SPECIAL 100

code:PA10100A

- Seduta con rivestimento in pelle Simil-Carbonio
- 1 Vano Portaoggetti H. 16cm
- 4 Gambe Fisse H. 50cm Ø30mm
- Tracolla Imbottita Ergonomica
- Livella Frontale
- *Seat with carbon look leather cover*
- *1 Accessory's storage h. 16cm*
- *4 Gambe Fisse H. 50cm Ø30mm*
- *Shoulder strap for transport*
- *1 Frontal level*



3,9 kg

Ø 30mm



5,2 kg

Ø 30mm

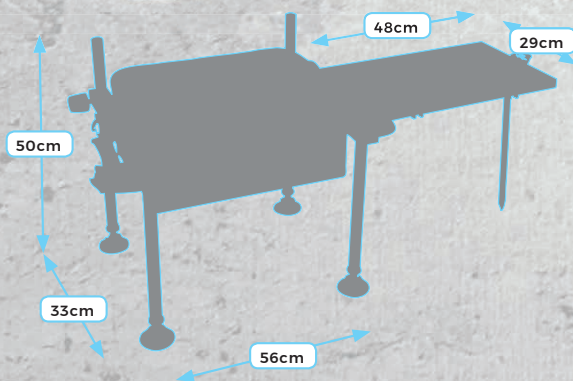

IROS SPECIAL 100 FST

code:PA10100B

- Seduta con rivestimento in pelle Simil-Carbonio
- 1 Vano Portaoggetti H. 16cm
- 4 Gambe Fisse H. 50cm Ø30mm
- Tracolla Imbottita Ergonomica
- Livella Frontale
- Piatto laterale pieghevole + gamba telescopica
- *Seat with carbon look leather cover*
- *1 Accessory's storage h. 16cm*
- *4 Gambe Fisse H. 50cm Ø30mm*
- *Shoulder strap for transport*
- *1 Frontal level*
- *Folding side tray + telescopic leg*

IROS CARP SERIES

Rete ideata e progettata per competizioni alla Carpa. Infatti, la rete di 200g al metro quadro, supplisce ad ogni esigenza di resistenza e robustezza, caratteristiche che ogni Angler professionista richiede durante le competizioni in carpodromo. Dotate di Clip Press and Release System: meccanismo a scatti per la regolazione ottimale dell'inclinazione del primo anello.

A mesh conceived and designed for carp fishing competitions. This mesh of 200g per square metre in effect meets all the requirements of strength and resistance that every professional angler is looking for during competitions in the carp fishery. Equipped with Clip Press and Release System: snap mechanism for the perfect adjustment of the inclination of the first ring.

ROUND

1° Ring Aluminium Ø 12mm: Ø 55cm
Other Rings Steel Ø 4mm: Ø 45cm
Distance: 40cm
Press and Release

CODE	sizes (m)	rings
NACR110A	2,50	7
NACR110B	3,00	8
NACR110C	3,50	9
NACR110D	4,00	10

SQUARED

1° Ring Aluminium Ø 12mm: 57cm x 47cm
Other Rings Steel Ø 4mm: 52cm x 42cm
Distance: 40cm
Press and Release

CODE	sizes (m)	rings
NACR112A	2,50	7
NACR112B	3,00	8
NACR112C	3,50	9
NACR112D	4,00	10



**CLIP
PRESS AND
RELEASE**



STEEL KARP SERIES

Rete ideata e progettata per competizioni in canale e in fiume. Infatti, la rete di 160g al metro quadro, è il perfetto compromesso tra leggerezza e resistenza, caratteristica che ogni Angler professionista richiede durante le competizioni. Dotate di Clip Press and Release System: meccanismo a scatti per la regolazione ottimale dell'inclinazione del primo anello.

A mesh conceived and designed for competitions in canal and river. This mesh of 160g per square metre is in effect the perfect compromise between lightness and strength, which is the characteristic that every professional angler is looking for during competitions. Equipped with Clip Press and Release System: snap mechanism for the perfect adjustment of the inclination of the first ring.

ROUND

1° Ring Aluminium Ø 12mm: 55cm
Other Rings Steel Ø 4mm: 45cm
Distance: 40cm
Press and Release

CODE	sizes (m)	rings
NACR100A	2,50	7
NACR100B	3,00	8
NACR100C	3,50	9
NACR100D	4,00	10

SQUARED

1° Ring Aluminium Ø 12mm: 57cm x 47cm
Other Rings Steel Ø 4mm: 52cm x 42cm
Distance: 40cm
Press and Release

CODE	sizes (m)	rings
NACR105A	2,50	7
NACR105B	3,00	8
NACR105C	3,50	9
NACR105D	4,00	10

TESTA: FIGHTING NET

Testa di guadino ideata per grosse prede. Per questo modello viene utilizzato il telaio in alluminio, resistente e indeformabile, abbinando ad una rete in polipropilene. Ideale per il carpodromo, ma anche per le competizioni in fiume dove le grosse prede risultano essere numerose.

Squared landing-net head designed for large preys. Its frame is made with a special ultra-light, non-deformable aluminium and its net is 100% water-repellent. Ideal to be used in commercial fisheries, but also for competitions in the river where there are many big preys.

CODE	sizes (cm)
GUST60A	47x56
GUST60B	53x63

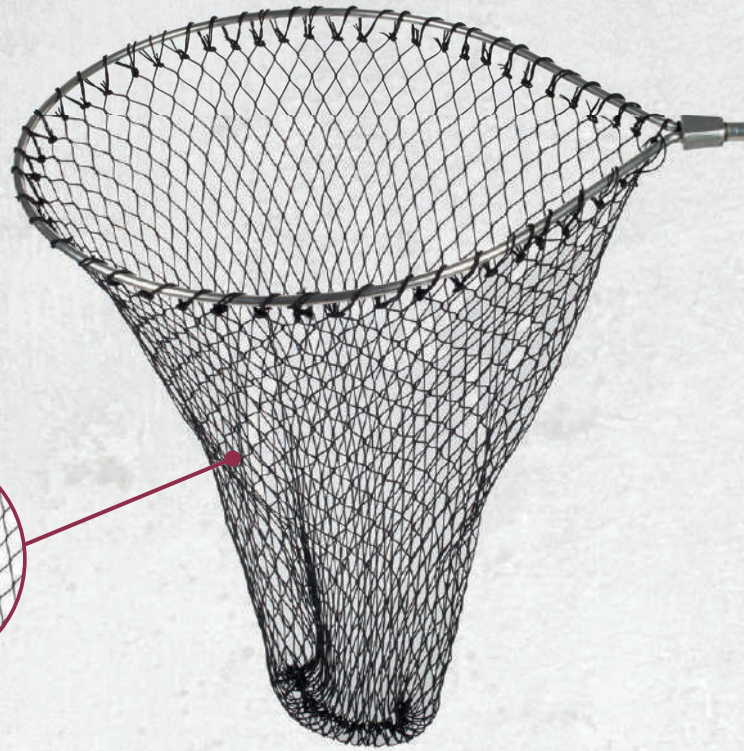

SIZE
30mmx30mm



72cm
X
72cm

OMBRELLONE DA ESCHE QUADRATO IN PVC

SQUARED PVC BAIT UMBRELLA

code:OMH12B

OMBRELLONE DA ESCHE QUADRATO IN PVC

SQUARED PVC BAIT UMBRELLA

code:OMH12A



85cm
X
85cm

MAGIC NET SERIES

Le MAGIC NET sono state studiate principalmente per poter areare il più possibile gli inneschi e le esche, durante le calde gare estive, garantendo così un'esca sempre fresca e attiva. La particolare rete utilizzata ha 2 vantaggi: il primo è che grazie alla sua ruvidità le esche si ripuliscono dalle impurità di conservazione, garantendone un miglior incollaggio e una "rosata" più unita se lanciate con la fionda; il secondo è che sia durante la pioggia sia nelle ore notturne quando l'umidità dell'aria è sostenuta, le esche non riescono a risalire le pareti e fuoriuscire. Trattandosi di reti con le MAGIC NET abbiamo un'ulteriore vantaggio; possiamo utilizzarle comodamente per lavare le nostre esche avanzate, immergendole direttamente in acqua.

The MAGIC NETS are mainly designed to enable ventilation of the lures and bait during those hot Summer competitions, thereby guaranteeing an ever fresh and active bait. The particular netting used has 2 advantages: The first is that, thanks to its roughness, the bait cleans itself of the impurities of captivity, guaranteeing better adherence and a more cohesive "rosy glow" when launched with a catapult; the second is that while it is raining, be that at night or during sustained humidity, the bait is not able to climb back up the walls and drop out. Being a net with MAGIC NET we have a further advantage; we can easily use them to wash our more advanced bait, immersing them directly into the water.



MAGIC NET

CODE	Ø (mm)	Ideato per contenere bigattini Designed for holding maggots
SC101A	120	
SC101B	140	
SC101C	160	
SC101D	200	
SC101E	225	

MICRO MAGIC NET

Ideato per contenere inneschi
Designed for holding hooks

CODE	Ø (mm)
SC100A	100
SC100B	120
SC100C	140



2018

NEW

COLMIC

01

ACCESSORI \ ACCESSORIES

www.colmic.it

ACCESSORIES

HIGH QUALITY



A

B

C

SECCHI OFFICIAL TEAM

GROUNDBAIT BUCKET OFFICIAL TEAM

	CODE	size
A	SEC31A	25 l
B	SEC32A	18 l
C	SEC33A	13 l



MASTELLO OFFICIAL TEAM

GROUNDBAIT VAT OFFICIAL TEAM

code:SEC30A (40 l)

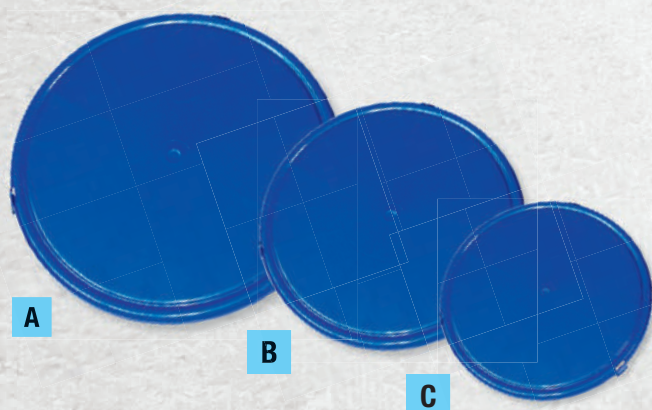

A

B

C

COPERCHI PER SECCHI OFFICIAL TEAM

LID FOR GROUNDBAIT BUCKETS OFFICIAL TEAM

	CODE	size
A	SEC31B	25 lt
B	SEC32B	18 lt
C	SEC33B	13 lt



BACINELLE PER SECCHI OFFICIAL TEAM

OFFICIAL TEAM BASINS FOR BUCKETS

	CODE	DESCRIPTION
A	SEC31C	BACINELLA 8 l PER SECCHIO 25 l - 8L BASIN FOR 25L BUCKET
B	SEC32C	BACINELLA 5 l PER SECCHIO 18 l - 5L BASIN FOR 18L BUCKET
C	SEC33C	BACINELLA 4 l PER SECCHIO 13 l - 4L BASIN FOR 13L BUCKET



BAIT BOX SERIES

	CODE	size
A	SC10B	0,60 l
B	SC10A	0,30 l



COVER PER BAIT BOX COVER FOR BAIT BOX

	CODE	DESCRIPTION
A	SC11B	COVER CON FORI - ONLY COVER WITH MICRO HOLES
B	SC11A	COVER SENZA FORI - ONLY COVER WITHOUT MICRO HOLES
C	SC11C	BORDO PER BAIT BOX - ONLY COVER EDGE

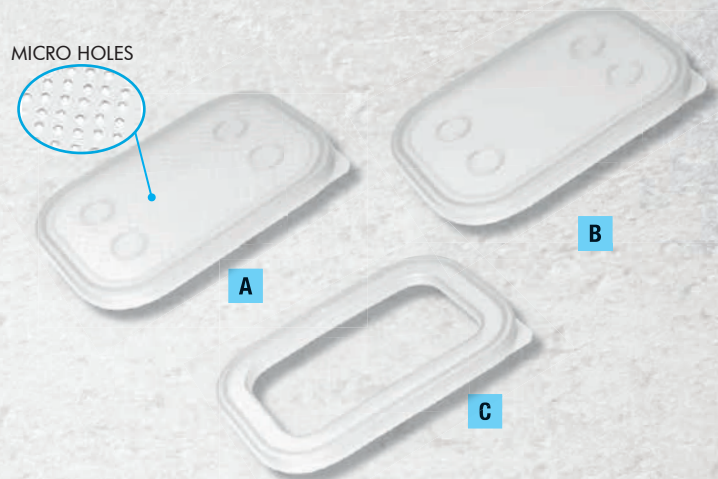

VAGLI MESH RIDLE

Vagli indicati per setacciare pasture e terre realizzati in diverse misure di maglie per ogni tipologia di terre e farine e con due diversi diametri per esser alloggiati sia sul secchio, sia sul mastello.

Round riddles designed for sifting groundbait and leams, produced with different gauge mesh for all types of groundbait texture, and in two different diameters to fit on the bucket and the tub.



CODE	sizes (cm)	mesh (mm)	CODE	sizes (cm)	mesh (mm)	CODE	sizes (cm)	mesh (mm)
VA25A	Ø 36	2	VA27A	Ø 44	2	VA26A	17x17	2
VA25B	Ø 36	3	VA27B	Ø 44	3			
VA25C	Ø 36	4	VA27C	Ø 44	4			
VA25D	Ø 36	5	VA27D	Ø 44	5			

MESH RIDLE Ø 44
HIGH STRONG PROFILE

CONSIGLIAMO WE RECOMMEND

Il vaglio con la maglia di diam. 2 per la setacciatura di terre, la maglia di diam. 3 per terre e pasture e le maglie di diam. 4-5 per pasture e tutti i tipi di sfarinati. The riddle with mesh of diameter 2 for sifting leams, the diameter 3 mesh for leams and groundbait mixes and the diameter 4-5 meshes for groundbaits and all types of mixes.

PINZA "SPLIT RING"

code:ST713PC

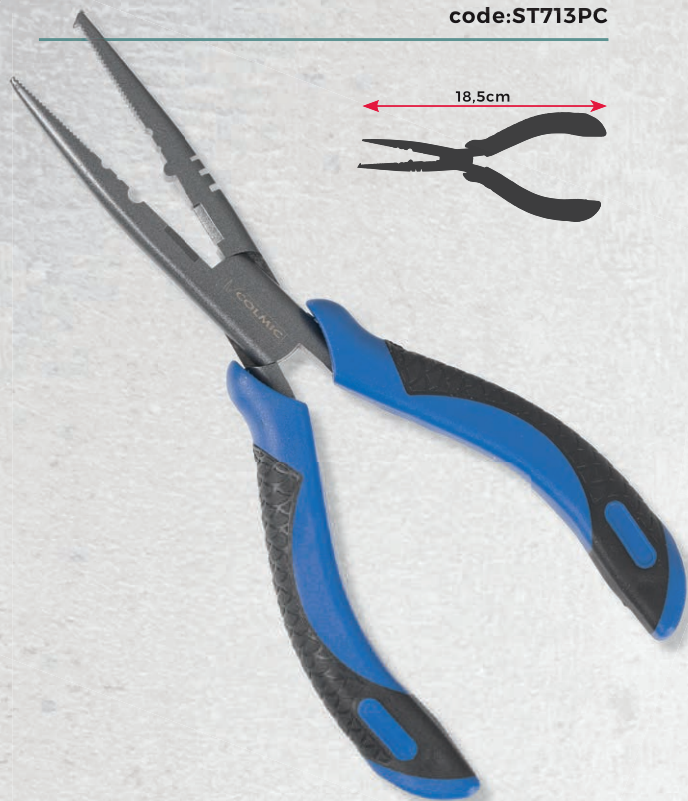
**WEED CUTTER PRO**

code:ST3001

Piccola falce da avvitare direttamente sulla boccia del manico per guadino, utile al taglio di erbe, arbusti e cannuce presenti in acqua e fuori - che in qualche modo ostacolano l'azione di pesca e il posizionamento degli accessori. Durevole, robusto ed efficace il Weed Cutter Pro si differenzia dal modello base (Weed Cutter stainless steel) per dimensioni ed ampiezza della curva. Viene corredato di una pratica custodia in similpelle.

Small sickle for screwing onto the handle bush of landing nets, useful for cutting grasses and reeds both in the water and out, which might somehow be an obstacle to fishing action and positioning of accessories. Durable, robust and effective, the Weed Cutter Pro is different from the basic model (Weed Cutter stainless steel) due to its size and the sweep of the curve. It is supplied with a practical sleeve in leatherette.

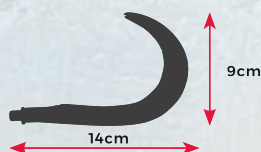
**FOLDING BRAIDED SCISSORS**

code:ST997

**WEED CUTTER STAINLESS STEEL**

code:ST3002

Piccola falce da avvitare direttamente sulla boccia del manico per guadino utile al taglio di erbe e cannuce presenti in acqua e fuori che in qualche modo possono ostacolare l'azione di pesca e il posizionamento degli accessori. Questo weed cutter è stato realizzato interamente in acciaio inox, ed è quindi il top sia dal punto di vista del taglio che da quello della durata del cosiddetto "filo" della lama. Leggero e poco ingombrante, può tranquillamente essere riposto ovunque.

Small sickle for screwing onto the handle bush of landing nets, useful for cutting grasses and reeds both in the water and out, which might somehow be an obstacle to fishing action and positioning. This weed cutter is made completely out of stainless steel and is, therefore, of top quality with regard to its cutting action and for keeping an edge. Light and not cumbersome, it can easily be put anywhere.

**SONDE NÉOPRÈNE NEOPRENE PROBE**

2pcs per Bag

CODE	sizes
SOND10	10g
SOND15	15g
SOND20	20g
SOND30	30g
SOND50	50g



ASTUCCIO PORTAFINALI HOOKLENGHT RETAINING BOX

CODE	H.mm	Description
LIPO50	25	Finali da 15cm, 20cm, 24cm
LIPO51	35	Finali da 22cm, 26cm, 30cm, 33cm, 37cm
LIPO52	50	Finali da 29cm, 35cm, 40cm, 45cm, 50cm

NEW
DESIGN

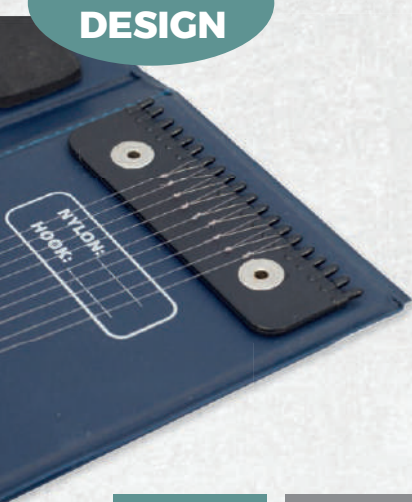

ELASTIC THREADER

code:INEL01

Comodo dispenser contenente 180 cm di acciaio armonico intrecciato da tenere sempre a portata di mano nel panier. Con questo utilissimo attrezzo risulterà agevole il montaggio di qualsiasi elastico in qualunque dimensione su vette cave classiche e filler tip.

Practical dispenser containing 180 cm of woven spring steel, to be kept handy in the panier at all times. With this very latest device, the assembly of any elastic paddle of any size on classic hollow tips and filler tips is made easy.



STAINLESS
STEEL

180cm

BAR ROLLER & ROD REST FEET

code:RUL002A

Comodi piedini ad incastro, ideali per posizionare in modo stabile il rullo e l'appoggia kit più vicino al terreno quando le condizioni del terreno lo necessitano. Facili e veloci da montare, sono compatibili con i rulli e gli appoggia kit Colmic indicati in tabella e modelli successivi.

Practical snap-on spike double feet, perfect to position the roller and the top kit holder lower on the ground when needed. Fast and easy to put on and off, available for the pole rollers and top kit holder below.



COMPATIBILITY

CODE	Description
RUL001	BAR ROLLER: COMPETIZIONE 37cm+37cm
RUL002	BAR ROLLER: COMPETIZIONE 30cm +30cm
RUL003	BAR ROLLER: EASY&FAST 50cm
AP00010	AP.KIT C/Gambe: COMPETITION 12 places
AP00011	AP.KIT C/Gambe: COMPETITION MATCH 12 places

SINKING VAPORIZER

code:AFF02 (250 ml)

Innovativo sistema a vaporizzazione per sgrassare il nylon utilizzato per la pesca con l'inglese. La sua esclusiva formula garantisce un totale l'affondamento anche solo con un leggerissimo colpo di canna, e una lunga durata.

Innovative vaporization system to degrease nylon used for fishing with wagglers. Its exclusive formula guarantees a long lasting total sinking even with a light rod stroke.



2018

NEW

COLMIC

105

ACCESSORI \ ACCESSORIES

www.colmic.it

SPECIAL SURF CASTING



SOFT FLUO CYLINDRIC ATTRACTORS (SINKING)

Cilindri in silicone realizzati con materiale soft, appositamente studiate per il surfcasting e bolentino. Realizzate in 4 differenti colorazioni, questi cilindri hanno ognuno una differente fluorescenza mediante esposizione a luce U.V.

Silicone cylinders made with soft material, specially designed for surfcasting and trolling. Made in 4 different colours, each with a different fluorescence under UV light exposure.

CODE	COLOR	FLUO	SIZE	pcs/bag
PE60A	PINK	ORANGE	5xØ4,5mm	25
PE60C	WHITE	GREEN	5xØ4,5mm	25
PE60D	WHITE/BLUE	GREEN/BLUE	5xØ4,5mm	25
PE60E	WHITE/ORANGE	GREEN/ORANGE	5xØ4,5mm	25



SUPER SOFT FLUO BEADS ATTRACTORS (FLOATING)

Perline in silicone realizzate con materiale ultra soft e con taglio dritto alle estremità per facilitarne l'inserimento dell'amo. Realizzate in 4 differenti colorazioni in due diverse misure (M-L) e con fluorescenza verde mediante esposizione a luce U.V., sono attrattori ideali sia per il surfcasting sia per il bolentino.

Silicone beads made with ultra soft material and with a cut straight to the ends to facilitate hook insertion. Made in 4 different colours, two different sizes (M-L) and with green fluorescence under UV light exposure, they are ideal attractors for both surfcasting and trolling.

CODE	COLOR	FLUO	SIZE	pcs/bag
PE50A	PINK	GREEN	M	20
PE50B	PINK	GREEN	L	20
PE50C	GREEN	GREEN	M	20
PE50D	GREEN	GREEN	L	20
PE50E	RED	GREEN	M	20
PE50F	RED	GREEN	L	20
PE50G	BLUE	GREEN	M	20
PE50H	BLUE	GREEN	L	20



CERAMIC MICRO BEADS

Micro perline in ceramica ideali per la realizzazione di Travi per SurfCasting, Beach Ledgering e Bolentino. Disponibili in due misure per coprire i vari diametri di Nylon e Fluorocarbon impiegati. Buste da 100pcs.

Ceramic micro beads ideal for surfcasting, beach ledgering and trolling beams. Available in two sizes for various nylon and fluorocarbon diameters. Bags with 100 pcs.

CODE	MAX in-line	SIZE	pcs/bag
PEC160	0,40mm	1,60mm	100
PEC200	0,60mm	2,00mm	100



SPECIAL SURF CASTING

2018

NEW

COLMIC

107

ACCESSORI \ ACCESSORIES

www.colmic.it

MINI TRAVI DA SURF CASTING

SURF CASTING DOWN RIGS

Robustissimi mini travi in acciaio completi di girella e rivestiti con guaina termosaldate per il consolidamento. Questi accessori si rivelano comodissimi per il surf casting, il beach ledgering ed il rock fishing. Inoltre risultano adatti anche a supportare impianti destinati alla pesca con il vivo e per il montaggio di terminali in acciaio.

Very robust down rigs in steel complete with spinner and covered in heat shrink sheath for consolidation. These accessories are most convenient for surf casting, beach ledgering and rock fishing. Furthermore, they are also suitable for supporting installations for live bait fishing and for assembling steel terminals.

CODE	SIZE	pcs/bag
MT004	4cm	2
MT007	7cm	2

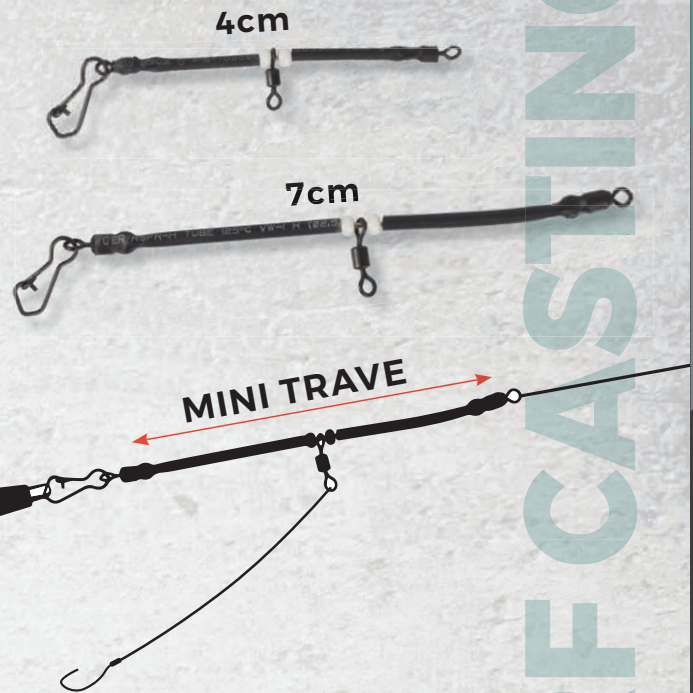

BAITS NEEDLE

Aghi da esche in acciaio inox della migliore forgia e qualità disponibili in due diversi diametri e lunghezze. L'ago da 30cm con diametro di 0,80mm è particolarmente indicato per l'innesco di arenicola, americano, coreano, tubicola, muriddu e tutti i vermi in genere. L'ago da 20 cm con diametro di 1,00mm si presta invece ad essere utilizzato per l'innesco cosiddetto "a sigaretta" dei piccoli filetti di sardina e per quello del cannicchio.

Baiting needles in stainless steel from the best forge and finest quality, available in two different diameters and lengths. The 30 cm needle with a diameter of 0,80mm is particularly suited for baiting sandworms, American and Korean worms, bristle worm, bobbit worm and all worms in general. The 20 cm needle with a diameter of 1.00 cm is on the other hand useful for baiting small fillets of sardine and razor shells in the so called "cigarette style".

CODE	SIZE	Diam.	pcs/ tube
AG1001	20cm	Ø1,10mm	5
AG1002	30cm	Ø0,80mm	5

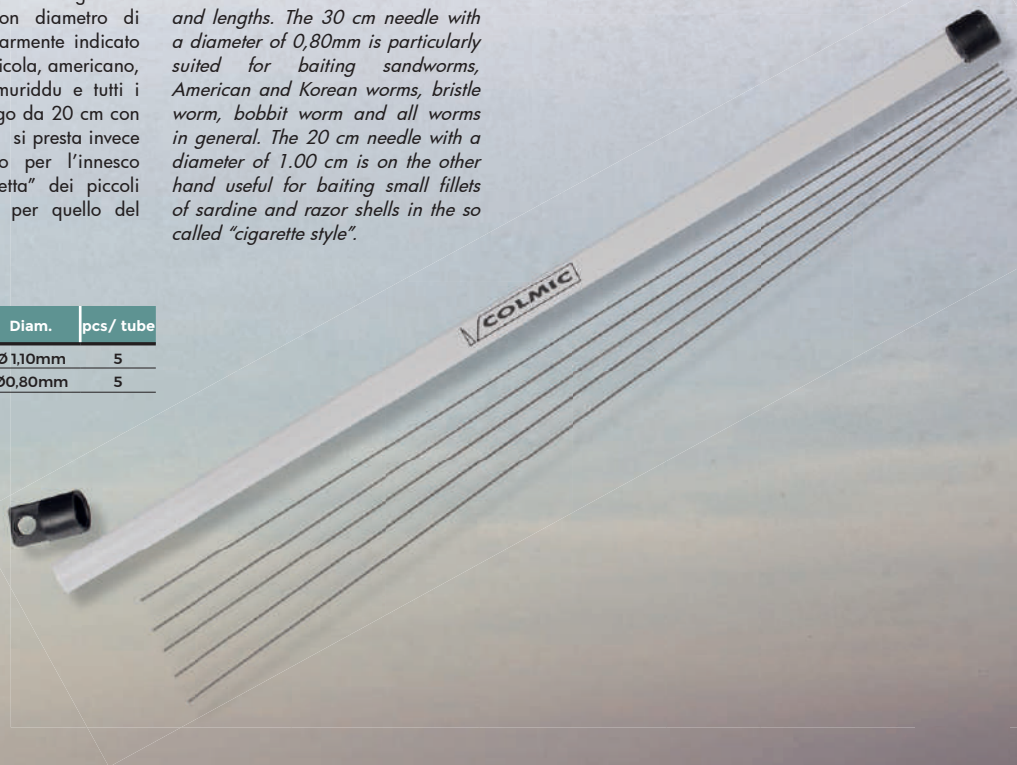

SPECIAL SURF CASTING



COLMIC SUNGLASS

Gli occhiali da pesca Colmic sono stati studiati e realizzati con materiali di standard elevati che permettono di essere performanti, funzionali e leggeri nelle azioni di pesca. Grazie alle loro lenti polarizzate filtrano i riverberi senza la distorsione ottica e la mancanza di nitidezza. Vengono dotati di custodia protettiva, utile panno per la pulizia delle lenti e un comodo cinturino.

Colmic fishing glasses have been designed and manufactured with high standard materials to make them high-performing, functional and light for fishing. Thanks to polarized lenses they filter reflections without any optical distortion or sharpness reduction. They come with a protective case, a useful lens cleaning cloth and a comfortable strap.



RIVER SNAKE POLARIZED

code:SUN01 - 3pc per pak



RIVER KILLER POLARIZED

code:SUN02 - 3pc per pak



COLMIC S

COLMIC SUNGLASS

2018

NEW

COLMIC

109

ACCESSORI \ ACCESSORIES

www.colmic.it



RIVER SILE POLARIZED

code:SUN03 - 3pc per pak



CRUNA SEA POLARIZED / MIRRORED

code:SUN04 - 3pc per pak



DARKO SEA FLOATING POLARIZED / MIRRORED

code:SUN05 - 3pc per pak



TUNA SEA POLARIZED / MIRRORED

code:SUN06 - 3pc per pak

SUNGLASS

SABIKI



Hayabusa

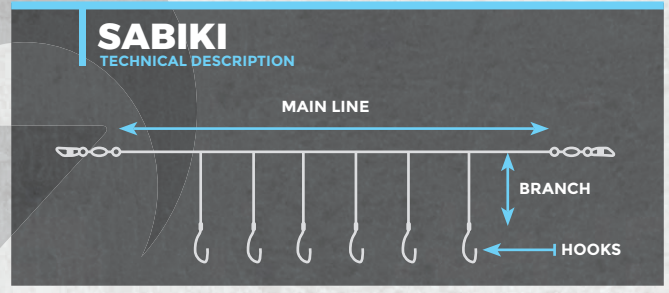

S500E

MIX - YARN



6 Hooks
10pcs per Pack

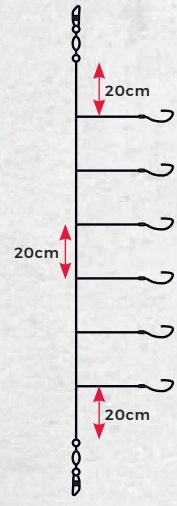
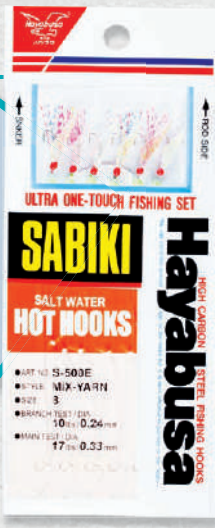

CODE	Hooks		Main Line Lenght - Diameter	Branch Lenght - Diameter
	Japan	European		
HAYAS50006	6	10	1,40m - Ø 0,29mm	5 cm - Ø 0,21mm
HAYAS50008	8	8	1,40m - Ø 0,33mm	5 cm - Ø 0,24mm

S501E

MIX - YARN



6 Hooks
10pcs per Pack

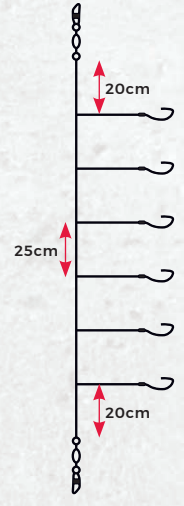
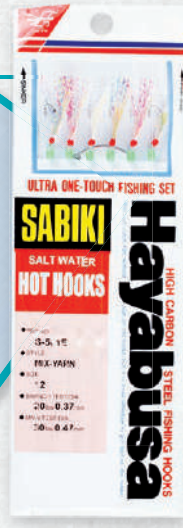

CODE	Hooks		Main Line Lenght - Diameter	Branch Lenght - Diameter
	Japan	European		
HAYAS50110	10	6	1,65m - Ø 0,47mm	8 cm - Ø 0,37mm
HAYAS50112	12	4	1,65m - Ø 0,47mm	8 cm - Ø 0,37mm

EX-110

SILVER FISH SKIN



6 Hooks
10pcs per Pack

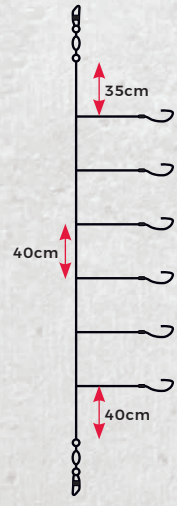

CODE	Hooks		Main Line Lenght - Diameter	Branch Lenght - Diameter
	Japan	European		
HAYAS11014	14	2	2,75m - Ø 0,44mm	14 cm - Ø 0,37mm
HAYAS11016	16	1	2,75m - Ø 0,47mm	14 cm - Ø 0,40mm

EX - 111

GOLD FISH SKIN



6 Hooks
10pcs per Pack

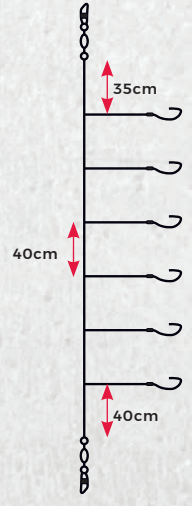

CODE	Hooks		Main Line Lenght - Diameter	Branch Lenght - Diameter
	Japan	European		
HAYAS11114	14	1	2,75m - Ø 0,44mm	14cm - Ø 0,37mm
HAYAS11116	16	2	2,75m - Ø 0,40mm	14cm - Ø 0,47mm

EX-120

GOLD FLASHER



REAL FISH SKIN

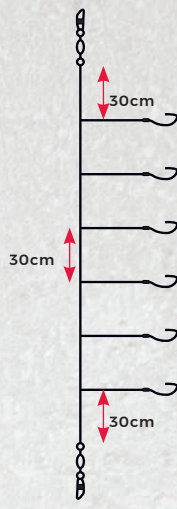

6 Hooks
10pcs per Pack

CODE	Hooks		Main Line Length - Diameter	Branch Length - Diameter
	Japan	European		
HAYAS120008	8	8	2,10m - Ø 0,29mm	10 cm - Ø 0,21mm
HAYAS120009	9	10	2,10m - Ø 0,33mm	10 cm - Ø 0,24mm
HAYAS120010	10	6	2,10m - Ø 0,37mm	10cm - Ø 0,29mm
HAYAS120012	12	2	2,10m - Ø 0,39mm	10cm - Ø 0,33mm

HS-425



Seaguar

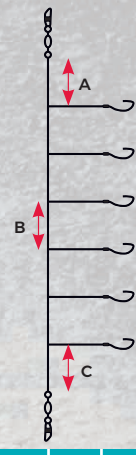

6 Hooks
10pcs per Pack

CODE	A cm	B cm	C cm
HAYAS42562	20	20	20
HAYAS42583	25	25	25

CODE	Hooks		Main Line Length - Diameter	Branch Length - Diameter
	Japan	European		
HAYAS42562	6	10	1,40m - Ø 0,33mm	3 cm - Ø 0,24mm
HAYAS42583	8	6	1,75m - Ø 0,37mm	5 cm - Ø 0,29mm

HS-351



REAL FISH SKIN

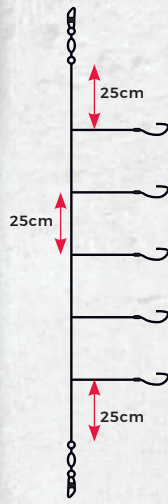

5 Hooks
10pcs per Pack

CODE	Hooks		Main Line Length - Diameter	Branch Length - Diameter
	Japan	European		
HAYAS35163	6	6	1,50m - Ø 0,37mm	8 cm - Ø 0,29mm
HAYAS35184	8	2	1,50m - Ø 0,47mm	8 cm - Ø 0,33mm

HS-713



REAL FISH SKIN

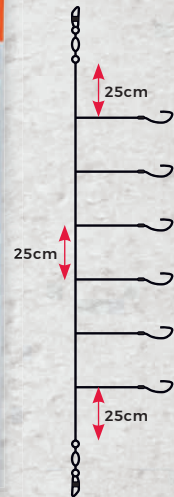

6 Hooks
10pcs per Pack

CODE	Hooks		Main Line Length - Diameter	Branch Length - Diameter
	Japan	European		
HAYAS71371	7	12	1,75m - Ø 0,29mm	5 cm - Ø 0,21mm
HAYAS71382	8	10	1,75m - Ø 0,29mm	5 cm - Ø 0,24mm

HS-714



REAL FISH SKIN

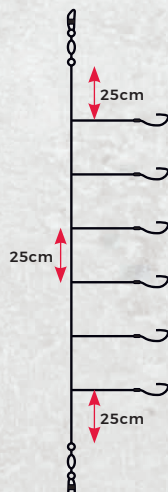

6 Hooks
10pcs per Pack

CODE	Hooks		Main Line Length - Diameter	Branch Length - Diameter
	Japan	European		
HAYAS71471	7	10	1,75m - Ø 0,29mm	5 cm - Ø 0,21mm
HAYAS71492	9	6	1,75m - Ø 0,37mm	5 cm - Ø 0,24mm

HS-715



REAL FISH SKIN

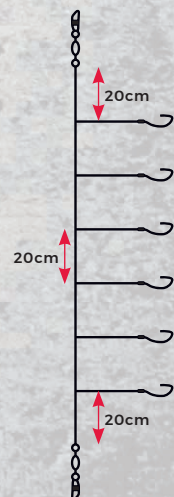

6 Hooks
10pcs per Pack

CODE	Hooks		Main Line Length - Diameter	Branch Length - Diameter
	Japan	European		
HAYAS71581	8	6	1,75m - Ø 0,29mm	3 cm - Ø 0,21mm

COLMIC IN THE WORLD

ITALY

VALLE D'AOSTA, PIEMONTE

Alberto Varesini

348 4443595 - albertovaresini@colmic.it

LOMBARDIA

(province: BG-BS-CR-MN)

Stefano Premoli

334 9415339 - s.premoli@colmic.it

(province: CO-LC-MI-PV-SO-VA-LO-MB)

Stefano Negri

335 7108567 - stefanonegri@colmic.it

TRENTINO ALTO ADIGE, FRIULI VENEZIA GIULIA, VENETO

Alessandro Cavallini

335 6824124 - sandro.cavallini55@alice.it

EMILIA ROMAGNA

(province: PR-PC)

Stefano Premoli

334 9415339 - s.premoli@colmic.it

(province: BO-FO-MO-RA-RN)

Gian Franco Reali

3483417532 - gianfrancoreali@colmic.it

(province: FE)

Alessandro Cavallini

335 6824124 - sandro.cavallini55@alice.it

LIGURIA

Alberto Varesini

348 4443595 - albertovaresini@colmic.it

TOSCANA

(province: FI-PT-PO)

Gianluca Meniconi

335 7797140 - gianlucameniconi@colmic.it

(province: AR- LU-MS-GR-PI-LI-SI)

Alessandro Degl'Innocenti

3355329609 - alessandrodeglinnocenti@colmic.it

UMBRIA - MARCHE

Gianluca Zampa

3356284642 - gianlucazampa@alice.it

LAZIO

(province: VT-RI)

Gianluca Zampa

3356284642 - gianlucazampa@alice.it

(province: LT-RM-FR)

Natalino Sarra

337766453 - natalinosarra@colmic.it

ABRUZZO - MOLISE

Tommaso Polidoro

3404872400 - t.polidoro@colmic.it

CAMPANIA

Clemente Carlino

3939334670 - clementecarlino@colmic.it

PUGLIA

(provincia: FG)

Tommaso Polidoro

3404872400 - t.polidoro@colmic.it

(province: BA-BR-LE-TA-BT)

Surano Pantaleo Fernando

3485823541 - surano.fernando@libero.it

BASILICATA

Iannuzzi Ruggero

3397979499 - ruggeroiannuzzi@colmic.it

CALABRIA

Salvatore Barberio

3386421502 - calabriapesca@hotmail.it

(province: CO - KR)

Iannuzzi Ruggero

3397979499 - ruggeroiannuzzi@colmic.it

SICILIA

Gianluca Burtone

3668026124 - gianlucaburtone@colmic.it

SARDEGNA

Pierluigi Corrias

3357757170 - pierluigicorrias@colmic.it

SPAIN

Juan Antonio Rodriguez Blasco

Madrid - Castilla de Mancha - Jaen

0034 616006115 - jarblasco@gmail.com

Antonio Jesus Escano Delgado

Aragon - Cataluna

0034 635522169 - antonioesca@hotmail.com

Juan Francisco Marin Duran

Caceres - Badajoz - Cordoba

0034 650067858 - richar_colmic@hotmail.com

Jesus Francisco Hernando Manso

Asturia - Castilla y Leon - Cantabria - Pais Vasco

La Rioja - Navarra

0034 617376166 - marnacu@gmail.com

Joaquin Vicente Ojeda Cantos

Huelva - Cadiz - Malaga - Granada - Almeria - Sevilla

0034 680135140 - jojedacanto@hotmail.com

Angel Chao Perez

La Coruña - Lugo - Orense - Pontevedra - Asturias

0034 656550186 - angelchaop@gmail.com

PORTUGAL

Joaquim Miguel Castanha Pinto

00351 938538865 - colmic@sapo.pt

FRANCE

Loyez Sebastien

Departements:

01-02-03-08-10-14-16-17-18-21-22-23-24-25-27-28-29-33-35-36-37-39-41-42-44-45-47-49-50-51-52-53-54-55-56-57-58-59-60-61-62-66-67-68-69-70-71-72-75-76-77-78-79-80-84-85-86-87-88-89-90-91-92-93-94-95

0033 665364516 - loyez-sebastien@hotmail.fr

Nicolas Bachevalier

Departements:

04-05-06-07-09-11-12-13-15-19-26-30-31-32-34-38-40-43-46-48-63-64-65-73-74-81-82-83

0033 632366821 - b.nicolas@live.fr

BELGIUM LUXEMBURG HOLLAND

Domenico Tomei

0032 477373631 - domenicotomei@colmic.it

GERMANY

Roberto Mazzasette

Gebiet 0 - Gebiet 1 - Gebiet 2-Gebiet 3 n.32/33-30/31-38-39-34-37 - Gebiet 4 N.48-49 - Gebiet 9 - Gebiet 8 N.82-83-84-85-86-87-80/81

0049 1706375471 - roberto@colmic.it

Kai Sheppach

Gebiet 3 N. 35 - Gebiet 4 N.46/47-44-45-41-40-42
Gebiet 5 - Gebiet 6 - Gebiet 7 - Gebiet 8 N. 89-88

0049 1703222735 - kai@colmic.it

AUSTRIA

Roberto Mazzasette

0049 1706375471 - roberto@colmic.it

UNITED KINGDOM

Northern of England - Scotland - Ireland

sales1@colmic.it

Midlands - Wales

sales2@colmic.it

Southern - England - London

sales3@colmic.it

ALGERY | AUSTRALIA | BELARUS | BRASIL |

BOSNIA HERZEGOVINA BULGARY | CYPRUS |

CROATIA | CZECH REP. | DENMARK |

EGYPT | ESTONIA | FINLAND |

GREECE | HUNGARY | IRAN |

ISRAEL | LATVIA | LITHUANIA |

MACEDONIA | MALTA | MAROCCO |

NORWAY | POLAND | ROMANIA |

RUSSIA | SERBIA | SLOVAKIA |

SLOVENIA | SWISS | SWEDEN | UAE |

UKRAINE | TUNISIA | TURKEY |

FOLLOW US

Colmic and Herakles News



@ColmicItaliaSpa



COLMIC ITALIA Spa

@colmicitaliaspa



@ColmicItalia



CREATED BY
COLMIC graphics studio
design & photos by Tomas Magri
graphic design by Emanuele Santi
photos by Silvano Silvia

Si ringrazia tutti coloro che hanno contribuito alla realizzazione di questa pubblicazione.

Tutti i diritti riservati. Vietata la riproduzione anche parziale di testi e immagini.
Colmic Italia Spa si riserva il diritto di apportare eventuali modifiche sui prodotti presentati su questo catalogo. © 2018



CHAMPION QUALITY IN FISHING TACKLE

COLMIC ITALIA S.p.A. a socio unico | Loc. Ruota al Mandò | 50068 Reggello (FI)
Tel. (+39) 055 8657079 | Fax (+39) 055 8657174 | colmic@colmic.it | www.colmic.it

