

# CATALOG 2017

ITALIANO - ENGLISH



 **COLMIC**

CHAMPION QUALITY IN FISHING TACKLE

# INDEX

## CANNE - RODS

Top Kits	6
Roubasienne	10
Margin Pole	26
Bolo	28
Fisse - Whips	37
Alborella - Bleak	40
Trota - Trout	41
Telematch	45
Inglesì - Match Rods	48
Surf Casting 3 Sect.	54
Surf Casting Telescopic	60
Beach Ledgering	62
Telebeach Mormora	65
Barca - Boat 2-3 Sect.	68
Barca Teleregolabile - Boat Teleadjustable	76
Barca Telescopica - Boat Telescopic	78
Big Game - Trolling	80
Jigging	85
Manici di guadino - Landing net handles	86
Fiber Glass & Carbon Solid Tips	91

## AMI - HOOKS

Nuclear	92
Hayabusa	100
Assist Hooks	107
Finali - Hook lengths	108
Sabiki Hayabusa	110

## GALLEGGIANTI - FLOATS

Galleggianti - Floats	114
Antenne - Antennas	153

## ABBIGLIAMENTO - CLOTHING

Abbigliamento - Clothing	154
--------------------------	-----

## BORSETTERIA - LUGGAGE

Portacanne - Holdall	168
Borse Trevira - Trevira Bags	178
Borse PVC - PVC Bags	186

## FILI - LINES

Braided Line	192
Fluorocarbon	196
Nylon: NxGen	200
Nylon	206
Nylon Big Game	211

## MULINELLI - REELS

Mulinelli - Reels	212
Omoto	220

## PANIERI - SEAT BOXES

Panieri - Seat boxes	222
Accessori - Accessories	229

## APPOGGIA CANNE E RULLI ROD HOLDERS & ROLLERS

Appoggia canne e rulli - Rod holders & rollers	244
--	-----

## NASSE E TESTE DI GUADINO KEEPNETS AND LANDING NET HEADS

Nasse - Keepnets	252
Teste di guadino - Landing Net Heads	258

## ACCESSORI - ACCESSORIES

Ombrelloni - Umbrellas	266
Sedie - Chairs	268
Fionde - Catapults	269
Coltelli e pinze - Knives and pliers	272
Secchi per pasture - Groundbait buckets	276
Vagli - Mesh riddles	277
Scatole in plastica - Plastic boxes	278
Accessori RBS - RBS accessories	280
Piombi - Leads	290
Accessori mare - Sea accessories	296
Materiale Espositivo - Display Material	301

## PASTURE - GROUNDBAITS

Pasture - Groundbaits	302
-----------------------	-----

## GIRELLE - SWIVELS

Girelle - Swivels	316
-------------------	-----

## FEEDER

Canne 3 sect - Rods 3 sect.	322
Telescopiche - Tele Rods	331
Canne 2 sect - Rods 2 sect.	332
Pasturatori - Feeders	336
Accessori - Accessories	342
Pasture - Groundbaits	344



## UN TEAM VINCENTE THE WINNING TEAM

Dal 1978, anno di fondazione dell' azienda, Colmic è sinonimo di altissimo livello tecnico, ricerca tecnologica, sviluppo di nuovi materiali e design sempre all' avanguardia, sempre associati ad un controllo rigoroso ed attento alla qualità dei prodotti commercializzati.

La Missione di Colmic è di creare e produrre attrezzatura da pesca che sia una sintesi perfetta di tecnologia e design, l' espressione di una meticolosa analisi ed una continua ricerca di perfezione, assicurando alla gamma di produzione un elevato e costante livello di affidabilità. Tale livello è garantito da una continua e sistematica attività di progettazione e controllo che si avvale di personale altamente qualificato sia interno all'azienda che nell' attività agonistica sportiva.

La grande passione ed esperienza di Andrea Collini, titolare dell' azienda, affiancato dalla freschezza innovativa di Alessandro Collini, amministratore delegato, è stata determinante nel coinvolgimento, nel progetto Colmic, di Campioni del Mondo di altissimo livello come Jacopo Falsini, Product Development Consulting, e Franco Mancini Spinning Sale & Department Manager, che operano attivamente all' interno dell' azienda, creando un Team vincente a livello mondiale.

*Since 1978, year of foundation of the company, Colmic is synonymous of high quality level, technical research, new materials development, the latest design and a total and strict quality control of our product.*

*Colmic commitment is to develop and manufacture a fishing tackle range that is a perfect synthesis between technology and design, result of a meticulous analysis and continuous pursuit of the perfection, assuring a total reliability standard to the whole assortment of products. This reliability standard is achieved through a systematic and continuous projecting and controls action inside the company and in the competition fishing arena.*

*The great passion and experience of Andrea Collini, general manager of the company, supported by the freshness of Alessandro Collini, CEO of the company, has been determinant to involve in the project World Champs like Jacopo Falsini, Product Development Consultant, and Franco Mancini, spin fishing sales & department manager, full time involved in the company management in a worldwide winning team.*

PASSION,  
TECHNOLOGY  
AND DESIGN



# CHAMPION QUALITY IN FISHING TACKLE



U.L.A.F. PRO FORCE è un particolare processo di stratificazione che crea una sottilissima membrana (o lamina) di carbonio composta da fibre orientate in tre direzioni. Lo speciale orientamento e l'esclusiva resina Filler Inside ad alta densità, già impiegata per l'impregnazione del carbonio U.L.A.F. donano una elasticità superiore, riducendo il peso che fino ad oggi era necessario per aumentare la capacità di assorbire urti.

*PRO FORCE U.L.A.F. is a special process of stratification that creates a superfine membrane (or foil) of carbon composed of fibres arranged in three different directions. This particular orientation and the exclusive high-density Filler Inside resin, already utilized for the impregnation of the Ultra-Light Aerospace Fibre carbon, yield greater flexibility, reducing the weight that was previously required to boost the shock-absorbing capacity.*



Alla base di tutte le sezioni sono state applicate delle lamine in titanio per aumentarne la resistenza in compressione. Titanium Joint rende ogni sezione più robusta senza aggiungere pesi in eccesso.

*At the base of all sections have been wrapped Titanium foil layers, that increase the resistance to compression. The Titanium Joint Part system make every section stronger without adding weight in excess.*



Il Colmic Joint Line è un sistema di riferimento che permette di allineare le sezioni sull'asse di maggiore rigidità. Questo sistema è di particolare importanza sulle RBS dove la rigidità è di primaria importanza. Con il Joint Line si aumenta la rigidità del 12%.

*The Colmic Joint Line is a reference system which allows to align all section on the main rigid axis. This is mainly important on poles because of the big importance of its stiffness. Joint Line increases the stiffness of the 12%.*



Sono particolari trattamenti superficiali del carbonio che rende le sezioni porose, riducendo notevolmente l'attrito sulle sezioni stesse, tutto ciò si traduce in una maggiore scorrevolezza pescando con la roubaisienne.

*This is a surface treatment of carbon designed to give the sections a porous finish which minimizes the line friction on the rod or pole. This results in superior casting performance and improved pole sliding. In case of rain or humidity it makes the line not to stick on the rod.*



Questa sigla sta' ad evidenziare la particolare forma della parte terminale dell'attrezzo: infatti l'impugnatura è stata disegnata appositamente per una presa ancora più rapida, intuitiva ed ergonomica. Altro elemento importante di questa innovazione, è il perfetto collegamento tra parte verniciata e parte in neoprene senza nessuna variazione di diametro, caratteristica che rende ancor più ottimale la presa in generale.

*This abbreviation is used to highlight the particular shape of the end part of this handle: in fact, the grip has been specifically designed for a secure, intuitive and ergonomic handhold. Another important element of this innovation is the perfect link between the painted parts and the neoprene parts without any change to the diameter. This characteristic offers an even more optimal grip in general.*

## SCHEMA DI CURVATURA BENDING CURVE MODEL

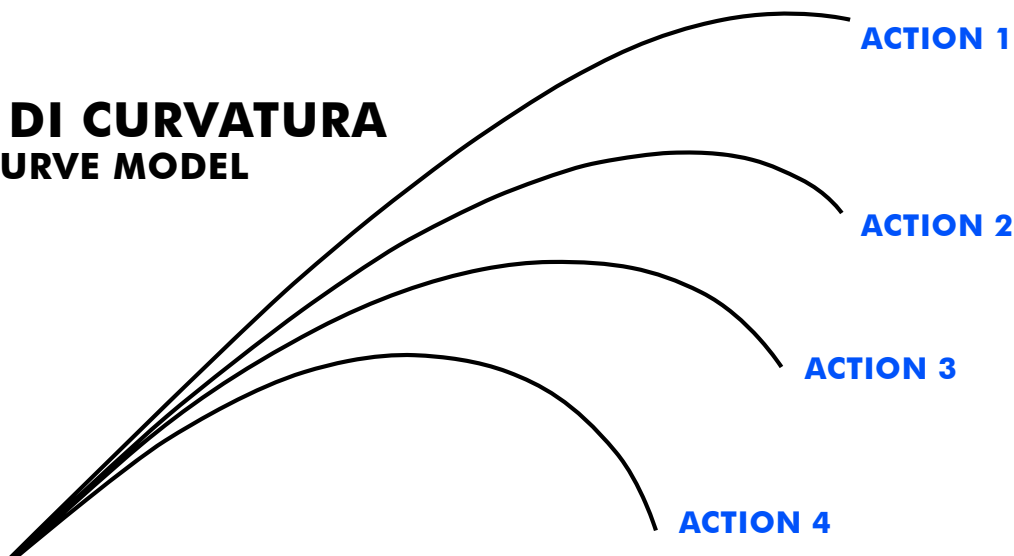

## PERFORMANCE SECTIONS

La Performance Section è studiata per ottenere il massimo del sopra base della roubaisienne sia a 13,00mt che a 11,50mt. Utilizzo dei migliori materiali senza influire su di essi con passaggi di levigatura, verniciatura ed etichettatura, che forse migliorano l'estetica ma ne peggiorano notevolmente il rendimento in pesca (le fasi sopracitate aumento il peso della sezione di circa 30gr che penalizzano la rigidità e le prestazioni della sezione stessa).

*The aim here is to obtain the best in term of performances from the second section of the 13.00mt and 11.50mt poles. In order to reach the best performances we focused on the quality of the materials avoiding all those manufacturing processes that give a better outfit but on the other hand they affect the performances. The finishing process can increase the weight of a section up to 30gr so affecting the stiffness and the performances of the section.*

## MULTI BUTT SYSTEM

Le Multi Butt sono sicuramente un attrezzo di grande utilità. In una canna a 13,00mt la Multi Butt specifica servirà non solo come base a 13,00mt, ma potrà essere utilizzata anche come base a 11,50mt, e con migliori prestazioni. La Multi Butt per la 11,50mt potrà essere ugualmente utilizzata anche come base a 10mt. Questo particolare accorgimento, ci consentirà in primo luogo di ottenere una roubaisienne con prestazioni elevatissime e ci darà quella sicurezza che non avremo mai pescando direttamente con il sopra base.

*These multipurpose butts are certainly of great use. With a 13.00mt pole it can serve as butt both at 13.00mt and at 11.50mt length with even better performances. Instead with a 11.50mt pole it can indifferently be used at 11.50mt length and at 10.00mt length. This tool will increase the performances of your RBS and it will also give you much safety more than fishing directly with the second section.*

## REINFORCED AREA

Si trova su tutte le seconde sezioni che supportano i filler tip e su tutte le 3° sezioni match. L'area rinforzata serve per creare un foro, senza danneggiare la sezione, dove si può applicare lo stripper.

*You find the reinforced area in all the 2th sections supporting Filler tip and in all the 3th match sections. The function of the reinforced area is to avoid damaging the section in rilling the whole where to put the stripper.*

## EVA CONE

Sono delle mini estensioni di altissima qualità che garantiscono un'impugnatura in assoluta sicurezza, studiate per essere usate su tutti gli elementi delle roubaisienne a partire dalla 4 sezione. Raccomandiamo il pescatore di usare le mini butt per evitare spiacevoli rotture delle sezioni.

*Mini butts are high quality mini extensions that assure a very secure grip, mini butts fit to all the RBS pieces from the 4th section on. We recommend the angler to use the mini butt in order to minimize the risk of section breaks.*

## MINI BUTT

Tutte le mini prolunghe sono dotate di protezioni in Neoprene da entrambe le estremità. Queste protezioni consentono di velocizzare le operazioni di innesto e disinnesto delle sezioni, di prevenire rotture accidentali e smussare il profilo dell'innesto delle Mini Butt con eliminazione del profilo a taglio.

*All the mini extensions are gifted with Neoprene protection on both extremities. This protection permits to speed up the section engagement and disengagement operations, prevent accidental breakage during the recovery phase, soften the Mini Butt section shape, allowing rapid deployment*

## STRIPPER

code:STRIP01

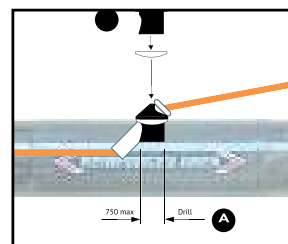
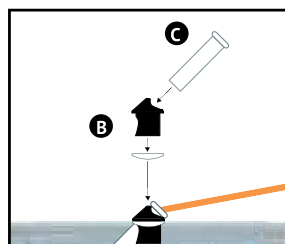

S  
T  
R  
I  
P  
S



## CERAMIC SLOT

5 PCS PER PACK  
 ROUND (ID: 4,30MM) - CODE:STRIP02  
 ROUND (ID: 5,80MM) - CODE:STRIP02A  
 OVAL (ID: 4,00MM) - CODE:STRIP03



		MT	TOP I.D.	KIT MATCH	KIT CARPA	REINFORCE AREA	CERAMIC SLOT	QUALITY
<b>TOP KIT "EM" (SST - Anti Sliding)</b>								
<b>CCX1310A</b>	TOP KIT 5 sect. "EM-150/00"	6,00mt	2,50mm	X		X		◆◆◆◆◆
<b>CCX1310B</b>	TOP KIT 5 sect. "EM-150"	6,00mt	2,50mm	X		X		◆◆◆◆◆
<b>CCX1312A</b>	TOP KIT 5 sect. "EM-100"	6,00mt	2,50mm	X		X		◆◆◆◆◆
<b>CCX1310C</b>	TOP KIT 4 Sect. "EM-150"	4,50mt	2,50mm	X		X		◆◆◆◆◆
<b>CCX1312A1</b>	TOP KIT 4 Sect. "EM-100"	4,50mt	2,50mm	X		X		◆◆◆◆◆
<b>SOLD OUT</b>	TOP KIT 4 Sect. "EM-95"	4,50mt	2,50mm	X		X		◆◆◆◆◆
<b>SOLD OUT</b>	TOP KIT 4 sect. "EM-80"	4,50mt	2,50mm	X		X		◆◆◆◆
<b>TOP KIT "EC" (SST - Anti Sliding)</b>								
<b>CCX1312D10A</b>	TOP KIT 4 sect. "EC-200S"	5,90mt	3,65mm		X	X		◆◆◆◆◆
<b>CCX1312D11</b>	TOP KIT 4 sect. "EC-150/00"	5,90mt	3,50mm		X	X		◆◆◆◆◆
<b>CCX1312D2</b>	TOP KIT 4 sect. "EC-150"	5,90mt	3,50mm		X	X		◆◆◆◆◆
<b>SOLD OUT</b>	TOP KIT 4 sect. "EC-100" (3°sect. 1,50mt)	5,90mt	3,50mm		X	X		◆◆◆◆◆
<b>CCX1312F01</b>	TOP KIT 4 sect. "EC-95S" (3°sect. 1,40mt)	5,80mt	3,65mm		X	X		◆◆◆◆◆
<b>CCX1312G1</b>	TOP KIT 4 sect. "EC-60"	5,70mt	3,65mm		X	X		◆◆◆
<b>CCX1312D10C</b>	TOP KIT 3 sect. "EC-200S"	4,40mt	3,65mm		X	X		◆◆◆◆◆
<b>CCX1312D3</b>	TOP KIT 3 sect. "EC-150"	4,40mt	3,50mm		X	X		◆◆◆◆◆
<b>CCX1312D5</b>	TOP KIT 3 sect. "EC-100S" (3°sect. 1,50mt)	4,40mt	3,65mm		X	X		◆◆◆◆◆
<b>CCX1312F03</b>	TOP KIT 3 sect. "EC-95S" (3°sect. 1,40mt)	4,30mt	3,65mm		X	X		◆◆◆◆◆
<b>CCX1312G2</b>	TOP KIT 3 sect. "EC-60"	4,30mt	3,65mm		X	X		◆◆◆
<b>TOP KIT "PM" (SST - Anti Sliding)</b>								
<b>CCX1313A</b>	TOP KIT 5 sect. PM-95	6,10mt	2,50mm	X		X		◆◆◆◆◆
<b>SOLD OUT</b>	TOP KIT 5 sect. PM-80	6,10mt	2,50mm	X		X		◆◆◆◆
<b>TOP KITS AIRON F66</b>								
<b>CCX1312D10B</b>	TOP KIT 4 sect. "EC-200S" Airon	5,90mt	3,65mm		X	X		◆◆◆◆◆
<b>CCX1312D4</b>	TOP KIT 4 sect. "EC-100S" Airon	5,90mt	3,65mm		X	X		◆◆◆◆◆
<b>CCX1312F02</b>	TOP KIT 4 sect. "EC-95S" Airon	5,80mt	3,65mm		X	X		◆◆◆◆◆
<b>POWER KITS &amp; OVERSIZES "M"</b>								
<b>CC8799C9F</b>	POWER KIT: OVERSIZE EC-300S POWER (no hole)	2,95mt	3,65mm		X	X		◆◆◆◆◆
<b>CC8799C9F1</b>	POWER KIT: OVERSIZE EC-200S POWER	2,95mt	3,65mm		X	X		◆◆◆◆◆
<b>CC8799C51</b>	SUPER POWER KIT: HM55-ST (w/hole)	2,95mt	3,50mm		X	X		◆◆◆◆◆
<b>CC8799C52</b>	SUPER POWER KIT: HM55-ST (no hole)	2,95mt	3,50mm		X	X		◆◆◆◆◆
<b>CC8799C6</b>	POWER KIT: HM40-ST (no hole)	2,95mt	3,50mm		X	X		◆◆◆◆
<b>SOLD OUT</b>	POWER KIT: HM40-ST (w/hole)	2,95mt	3,50mm		X	X		◆◆◆◆
<b>CC8799C9D</b>	POWER KIT: OVERSIZE M (no hole)	2,95mt	3,50mm		X	X		◆◆◆◆
<b>CC8799C9D1</b>	POWER KIT: OVERSIZE M (no hole)	2,95mt	3,50mm		X	X		◆◆◆◆
<b>SOLD OUT</b>	POWER KIT: OVERSIZE M SHORT (no hole)	2,80mt	3,50mm		X	X		◆◆◆◆
<b>SOLD OUT</b>	POWER KIT: OVERSIZE M SHORT (w/hole)	2,80mt	3,50mm		X	X		◆◆◆◆
<b>CC8799C93A</b>	POWER KIT: OVERSIZE EC-200S HYPER 30 (no hole)	2,90mt	3,65mm		X	X		◆◆◆
<b>CC8799C93B</b>	POWER KIT: OVERSIZE EC-200S HYPER 30	2,90mt	3,65mm		X	X	X	◆◆◆
<b>CC8799C8</b>	POWER KIT: HYPER-30 (w/hole)	2,95mt			X	X		◆◆◆
<b>CC8799C9</b>	POWER KIT: HYPER-30 (no hole)	2,95mt			X	X		◆◆◆
<b>CC8799C6A</b>	3° sect. "FORCE-4"	1,50mt			X	X		◆◆◆◆
<b>CC8799C6B</b>	3° sect. "FORCE-6"	1,50mt			X	X		◆◆◆◆

# TOP KITS

S

T

H

V

D

O

T



		MT	TOP I.D.	KIT MATCH	KIT CARPA	REINFORCE AREA	CERAMIC SLOT	QUALITY
<b>POWER KITS PC &amp; OVERSIZES "K"</b>								
<b>SOLD OUT</b>	SUPER POWER KIT: OVERSIZE K HM55 (no hole)	2,95mt	3,50mm		X	X		◆◆◆◆
<b>SOLD OUT</b>	SUPER POWER KIT: OVERSIZE K HM55 (w/hole)	2,95mt	3,50mm		X	X		◆◆◆◆
<b>CC8799C9A2</b>	POWER KIT: K-40 (no hole)	2,90mt	3,50mm		X	X		◆◆◆◆
<b>SOLD OUT</b>	POWER KIT: K-40 (w/hole)	2,90mt	3,50mm		X	X		◆◆◆
<b>CC8799C9A6</b>	POWER KIT: OVERSIZE EC-200S "K" HYPER 30 (no hole)	2,90mt	3,50mm		X	X		◆◆◆
<b>CC8799C9A7</b>	POWER KIT: OVERSIZE EC-200S "K" HYPER 30	2,90mt	3,50mm		X	X	X	◆◆◆
<b>SOLD OUT</b>	POWER KIT: K-HYPER 30 (no hole)	2,90mt	3,50mm		X	X		◆◆◆
<b>SOLD OUT</b>	POWER KIT: K-HYPER 30 (w/hole)	2,90mt	3,50mm		X	X		◆◆◆
<b>CC9306</b>	POWER KIT: Serie PC (no hole)	3,10mt	3,50mm		X	X		◆◆◆◆
<b>CC9306A</b>	POWER KIT: Serie PC (w/hole)	3,10mt	3,50mm		X	X		◆◆◆◆
<b>CC8799C9A</b>	POWER KIT: OVERSIZE K (no hole)	2,95mt	3,50mm		X	X		◆◆◆◆
<b>CC8799C9A1</b>	POWER KIT: OVERSIZE K (w/hole)	2,95mt	3,50mm		X	X		◆◆◆◆
<b>CCX1314A</b>	TOP KIT 3 sect. K-100	4,40mt	3,50mm		X	X		◆◆◆◆
<b>CC9305A</b>	TOP KIT 3 sect. - PC36	3,40mt	2,20mm	X		X		◆◆◆
<b>CC8799C7A</b>	3° sect. "FORCE-4 (K)"	1,45mt			X	X		◆◆◆◆
<b>SLIM SERIES</b>								
<b>CCX14XC2</b>	POWER KIT 2 sect. SLIM Series	3,10mt	3,60mm		X	X		◆◆◆◆
<b>CCX14XC1</b>	TOP KIT 4 sect. SLIM Series	3,70mt	2,20mm	X		X		◆◆◆◆
<b>CUPPING KITS</b>								
<b>CC8799C2A</b>	SUPER CUPPING KIT HM-60	2,85mt	4,50mm		X			◆◆◆◆◆
<b>SOLD OUT</b>	CUPPING KIT HM-40	2,85mt	3,50mm		X	X		◆◆◆◆
<b>POWER KITS &amp; TOP KITS BATCARP/C09</b>								
<b>CC9606A</b>	POWER KIT : CJ030 (no ring)	2,65mt	3,50mm			X		◆◆◆
<b>CC9606B</b>	POWER KIT : CJ030 (w/ring)	2,65mt	3,50mm			X	X	◆◆◆
<b>CC9603A</b>	TOP KIT 4 sect. (C-09/BATCARP) (no ring)	4,10mt	2,50mm			X		◆◆◆
<b>CC9603B</b>	TOP KIT 4 sect. (C-09/BATCARP) (w/ring)	4,10mt	2,50mm			X	X	◆◆◆
<b>CC9604A</b>	TOP KIT 3 sect. (C-09/BATCARP) (no ring)	2,70mt	2,50mm			X		◆◆◆
<b>CC9604B</b>	TOP KIT 3 sect. (C-09/BATCARP) (w/ring)	2,70mt	2,50mm			X	X	◆◆◆
<b>FILLER TIPS</b>								
<b>CC8900C7</b>	FILLER TIP MATCH SUPER LIGHT	1,60mt	2,70mm	X				◆◆◆◆◆
<b>CC9307</b>	FILLER TIP: Serie PC	1,70mt			X			◆◆◆◆
<b>CC8900C5</b>	FILLER TIP "LC"	1,50mt	3,40mm		X			◆◆◆◆
<b>CC8900C6</b>	FILLER TIP "OVERSIZE"	1,50mt	3,20mm		X			◆◆◆◆
<b>SINGLE SECTIONS</b>								
<b>CC8799D1</b>	1° sect. MATCH 350mm -Top ID 2,50mm	0,35mt	2,50mm	X				◆◆◆◆◆
<b>CC8799D</b>	1° sect. MATCH 500mm -Top ID 2,50mm	0,50mt	2,50mm	X				◆◆◆◆◆
<b>CC8799D2</b>	1° sect. MATCH 700mm -Top ID 2,20mm	0,70mt	2,20mm	X				◆◆◆◆◆
<b>CC8799E</b>	2° sect. MATCH - 1300mm	1,30mt		X				◆◆◆◆◆
<b>CC8799F1</b>	3° sect. MATCH-1.400mm W/ REINF. AREA	1,40mt		X		X		◆◆◆◆◆
<b>CC8799F2</b>	4° sect. MATCH-1.500mm (Serie EM)	1,50mt		X				◆◆◆◆◆
<b>CC8799F3</b>	5° sect. MATCH-1.500mm (Serie EM)	1,50mt		X				◆◆◆◆◆



		11022	SERIE 33-22 - DAITAN 9000 DAITAN 7000 - ROXY	9401 X3 - 7401X3 7401 - 6401	5501 - 5001 - 4001	SERIE AIRON PLANET CARP - CARPA2.0	THOR NX900 - STINGER CARP CARP RAIDER - QUASAR T9 EVO FIGHT	KARPER X3 - KARPER EVOL. KARP - PROTO CARP	SPECICARP	VULCAN - BETA-SM - GEMINI 500 CK-5000 - CARPA MG1	SPIRIT CARP POWER 100 - FORCE H1	BATCARP - C-09
<b>TOP KIT "EM" (SST - Anti Sliding)</b>												
CCX1310A	TOP KIT 5 sect. "EM-150/00"	X										
CCX1310B	TOP KIT 5 sect. "EM-150"		X	X			X					
CCX1312A	TOP KIT 5 sect. "EM-100"		X	X			X					
CCX1310C	TOP KIT 4 Sect. "EM-150"	X	X	X	X	X	X	X	X	X		
<b>SOLD OUT</b> CCX1310D	TOP KIT 4 Sect. "EM-100"	X	X	X	X	X	X	X	X	X		
<b>SOLD OUT</b> CCX1310E	TOP KIT 4 Sect. "EM-95"	X	X	X	X	X	X	X	X	X		
CCX1310D1	TOP KIT 4 sect. "EM-80"	X	X	X	X	X	X	X	X	X		
<b>TOP KIT "EC" (SST - Anti Sliding)</b>												
CCX1312D10A	TOP KIT 4 sect. "EC-200S"			X			X					
CCX1312D11	TOP KIT 4 sect. "EC-150/00"	X										
<b>SOLD OUT</b> CCX1312D12	TOP KIT 4 sect. "EC-150"		X	X			X					
CCX1312E	TOP KIT 4 sect. "EC-100"		X	X			X					
CCX1312F01	TOP KIT 4 sect. "EC-95S"		X	X			X					
CCX1312G1	TOP KIT 4 sect. "EC-60"		X	X			X					
CCX1312D10C	TOP KIT 3 sect. "EC-200S"	X	X	X	X	X	X	X	X	X		
CCX1312D3	TOP KIT 3 sect. "EC-150"	X	X	X	X	X	X	X	X	X		
CCX1312D5	TOP KIT 3 sect. "EC-100S"	X	X	X	X	X	X	X	X	X		
CCX1312F03	TOP KIT 3 sect. "EC-95S"	X	X	X	X	X	X	X	X	X		
CCX1312G2	TOP KIT 3 sect. "EC-60"		X	X	X	X	X	X	X	X		
<b>TOP KIT "PM" (SST - Anti Sliding)</b>												
<b>SOLD OUT</b> CCX1313A	TOP KIT 5 sect. PM-95				X			X	X	X		
CCX1313B	TOP KIT 5 sect. PM-80				X			X	X	X		
<b>TOP KITS AIRON F66</b>												
CCX1312D10B	TOP KIT 4 sect. "EC-200S" Airon					X						
CCX1312D4	TOP KIT 4 sect. "EC-100S" Airon					X						
CCX1312F02	TOP KIT 4 sect. "EC-95S" Airon					X						
<b>POWER KITS &amp; OVERSIZES "M"</b>												
CC8799C9F	POWER KIT: OVERSIZE EC-300S POWER (no hole)	X	X		X	X	X					
CC8799C9F1	POWER KIT: OVERSIZE EC-200S POWER	X	X		X	X	X					
CC8799C51	SUPER POWER KIT: HM55-ST (w/hole)	X	X		X	X	X					
CC8799C52	SUPER POWER KIT: HM55-ST (no hole)	X	X		X	X	X					
<b>SOLD OUT</b> CC8799C6	POWER KIT: HM40-ST (no hole)	X	X		X	X	X					
CC8799C53	POWER KIT: HM40-ST (w/hole)	X	X		X	X	X					
CC8799C9D	POWER KIT: OVERSIZE M (no hole)	X	X		X	X	X					
<b>SOLD OUT</b> CC8799C9D1	POWER KIT: OVERSIZE M (no hole)	X	X		X	X	X					
<b>SOLD OUT</b> CC8799C9E	POWER KIT: OVERSIZE M SHORT (no hole)	X	X		X	X	X					
CC8799C9E1	POWER KIT: OVERSIZE M SHORT (w/hole)	X	X		X	X	X					
CC8799C93A	POWER KIT: OVERSIZE EC-200S HYPER 30 (no hole)	X	X		X	X	X					
CC8799C93B	POWER KIT: OVERSIZE EC-200S HYPER 30	X	X		X	X	X					
CC8799C8	POWER KIT: HYPER-30 (w/hole)	X	X		X	X	X					
CC8799C9	POWER KIT: HYPER-30 (no hole)	X	X		X	X	X					
CC8799C6A	3° sect. "FORCE-4"	X	X		X	X	X					
CC8799C6B	3° sect. "FORCE-6"	X	X		X	X	X					



# TOP KITS COMPATIBILITY



		11022	SERIE 33-22 - DAITAN 9000 DAITAN 7000 - ROXY	9401 X3 - 7401X3 7401 - 6401	5501 - 5001 - 4001	SERIE AIRON PLANET CARP- CARPA2.0	THOR NX900 - STINGER CARP CARP RAIDER - QUASAR T9 EVO FIGHT	KARPER X3 - KARPER EVOL. KARP - PROTO CARP	SPECICARP	VULCAN - BETA-SM - GEMINI 500 CK-5000 - CARPA MG1	SPIRIT CARP POWER 100 - FORCE H1	BATCARP - C-09
<b>POWER KITS PC &amp; OVERSIZES "K"</b>												
<b>SOLD OUT</b>	SUPER POWER KIT: OVERSIZE K HM55 (no hole)			X				X	X	X		
<b>SOLD OUT</b>	SUPER POWER KIT: OVERSIZE K HM55 (w/hole)			X				X	X	X		
<b>CC8799C9A2</b>	POWER KIT: K-40 (no hole)			X				X	X	X		
<b>SOLD OUT</b>	POWER KIT: K-40 (w/hole)			X				X	X	X		
<b>CC8799C9A6</b>	POWER KIT: OVERSIZE EC-200S "K" HYPER 30 (no hole)			X				X	X	X		
<b>CC8799C9A7</b>	POWER KIT: OVERSIZE EC-200S "K" HYPER 30			X				X	X	X		
<b>SOLD OUT</b>	POWER KIT: K-HYPER 30 (no hole)			X				X	X	X		
<b>SOLD OUT</b>	POWER KIT: K-HYPER 30 (w/hole)			X				X	X	X		
<b>CC9306</b>	POWER KIT: Serie PC (no hole)			X				X	X	X		
<b>CC9306A</b>	POWER KIT: Serie PC (w/hole)			X				X	X	X		
<b>CC8799C9A</b>	POWER KIT: OVERSIZE K (no hole)			X				X	X	X		
<b>CC8799C9A1</b>	POWER KIT: OVERSIZE K (w/hole)			X				X	X	X		
<b>CCX1314A</b>	TOP KIT 3 sect. K-100			X				X	X	X		
<b>CC9305A</b>	TOP KIT 3 sect. - PC36			X				X	X	X		
<b>CC8799C7A</b>	3° sect. "FORCE-4 (K)"			X				X	X	X		
<b>SLIM SERIES</b>												
<b>CCX14XC2</b>	POWER KIT 2 sect. SLIM Series										X	
<b>CCX14XC1</b>	TOP KIT 4 sect. SLIM Series										X	
<b>CUPPING KITS</b>												
<b>CC8799C2A</b>	SUPER CUPPING KIT HM-60	X	X		X	X	X					
<b>SOLD OUT</b>	CUPPING KIT HM-40	X	X		X	X	X					
<b>POWER KITS &amp; TOP KITS BATCARP/C09</b>												
<b>CC9606A</b>	POWER KIT : CJ030 (no ring)											X
<b>CC9606B</b>	POWER KIT : CJ030 (w/ring)											X
<b>CC9603A</b>	TOP KIT 4 sect. (C-09/BATCARP) (no ring)											X
<b>CC9603B</b>	TOP KIT 4 sect. (C-09/BATCARP) (w/ring)											X
<b>CC9604A</b>	TOP KIT 3 sect. (C-09/BATCARP) (no ring)											X
<b>CC9604B</b>	TOP KIT 3 sect. (C-09/BATCARP) (w/ring)											X
<b>FILLER TIPS</b>												
<b>CC8900C7</b>	FILLER TIP MATCH SUPER LIGHT	X	X		X	X	X					
<b>CC9307</b>	FILLER TIP: Serie PC							X				
<b>CC8900C5</b>	FILLER TIP "LC"	X	X		X	X	X			X		
<b>CC8900C6</b>	FILLER TIP "OVERSIZE"			X		X	X	X	X			
<b>SINGLE SECTIONS</b>												
<b>CC8799D1</b>	1° sect. MATCH 350mm -Top ID 2,50mm	X	X		X							
<b>CC8799D</b>	1° sect. MATCH 500mm -Top ID 2,50mm	X	X		X							
<b>CC8799D2</b>	1° sect. MATCH 700mm -Top ID 2250mm	X	X		X							
<b>CC8799E</b>	2° sect. MATCH - 1300mm	X	X		X							
<b>CC8799F1</b>	3° sect. MATCH-1.400mm W/ REINF. AREA	X	X		X							
<b>CC8799F2</b>	4° sect. MATCH-1.500mm (Serie EM)	X	X		X			X	X	X		
<b>CC8799F3</b>	5° sect. MATCH-1.500mm (Serie EM)		X									

# ULTRALIGHT

*XXX*

## 11022

*XXX*

Canna RBS ultra leggera a 2 basi parallele. La 11022 top di gamma in casa colmic è la più leggera di tutta la serie (solo 835gr). Regina di tutte le canne Match è stata progettata con i migliori materiali sul mercato mondiale che la rendono rigida e molto affidabile. Sogno per ogni agonista.

*RBS rod with 2 parallel bases pole. The 11022 is the top on the range. It's the lightest of all the series (only 835 gr). It's the queen of all the Match poles. It was designed with the best materials on the world market that make it stiff and reliable. the 11022 it the dream of each competition fisherman.*

### PACK RBS 11022 13.00 MT

DESCRIPTION	PCS
POLE RBS 11022 mt 13,00 (9 sect. - Ø 42,00mm)	1
1° Mini Butt 60cm = Put-In Multi Butt (13,00 & 11,50mt)	1
2° Mini Butt 60cm - Reverse = 7° & 6° sect. (9,60mt & 7,90mt)	1
3° Mini Butt 60cm - Reverse = 5° & 4° sect. (6,40mt & 4,90mt)	1
TOP KIT 5 sect. "EM-150/00" (6,20mt)	4
3° Sezione "FORCE-4" (1,50mt)	1
CUPPING KIT HM-40 (2,85mt)	1
PVC Tubes	8
DURO ROD HOLDER: RBS XXL	1

CODE: CCX80P

DURO ROD HOLDER: RBS XXL



**MULTI BUTT SYSTEM**

ADDITIONAL MINI EXTENSION  
NOT INCLUDED - 85CM - 9°SECT. (11,50MT) - CODE:CCX80PM



MULETTO SFT-112 NOT INCLUDED - CODE:CCX80PB



# MATCH - CARPA

RBS

**9933**

XXX

Canna roubaisienne Match-Carpa a tre basi parallele. Top di gamma rigidissima, potente e indistruttibile risulta essere leggera (solo 900gr.) e affidabile.

*RBS rod with 3 parallel bases Match-Carpa pole. It's the top of the range. It's very stiff, powerful, strong and light at the same time (only 900 gr).*

**PACK RBS 9933 13.00 MT**

DESCRIPTION	PCS
RBS 9933 (13,00mt) (9 sect. - Ø 42,30mm)	1
1° Mini Butt 500mm = Put-In Multi Butt (13,00 & 11,50mt)	1
2° Mini Butt 500mm - Reverse = 7° & 6° sect. (9,40mt & 7,70mt)	1
3° Mini Butt 500mm - Reverse = 5° & 4° sect. (6,40mt & 4,90mt)	1
Top Kit 5 sect. EM-150 (6,05mt) SUPER MATCH	4
3° Sezione Force-4 ( 1,50mt)	1
SUPER CUPPING KIT HM-60	1
PVC Tubes	8
DURO ROD HOLDER: RBS XXL	1

CODE: CCX91P01

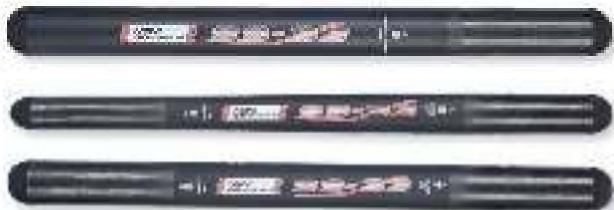

DURO ROD HOLDER: RBS XXL



**MULTI BUTT SYSTEM**

ADDITIONAL MINI EXTENSION  
NOT INCLUDED - 85CM - 9°SECT. (11,50MT) - CODE:CCX81PM



MULETTO SFT-103 NOT INCLUDED - CODE:CCX81PB



**SOLD OUT**

## DAITAN 9000

*XXT*

Canna roubaisienne a due basi parallele. Top di gamma nella categoria Match-Carpa, leggera, rigidissima ed altrettanto robusta. Ha un diametro sottile un peso ridotto e una reattività senza pari.

*Two base sections pole. The Daitan 9000 is the top of the Match-Carpa category, light and stiff at the same time. It has a thin diameter with a reduced weight and an incomparable reactivity.*

### DAITAN 9000 13.00 MT

DESCRIPTION	PCS
DAITAN 9000 13,00mt (9 sect. - Ø 44,70mm)	1
1° Mini Butt 65cm = Put-In Multi Butt (13,00 & 11,50mt)	1
2° Mini Butt Reverse = 7° & 6° sect. (11,50 mt & 10,00mt)	1
PUT-IN MULTI BUTT	2

**SOLD OUT**

**MULTI BUTT SYSTEM**

ADDITIONAL MINI EXTENSION  
NOT INCLUDED - 65CM - REVERSE 5° & 4°

**SOLD OUT**

MULETTO SFT-102 NOT INCLUDED - CODE:CCX83PB

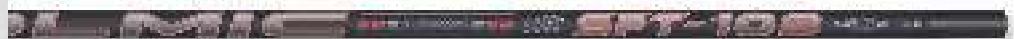

## DAITAN 7000

XXT

Canna roubaisienne a due basi parallele. Top di gamma nella categoria Match-Carpa, un gradino inferiore rispetto alla sorella, della quale però conserva tutte le caratteristiche di leggerezza, rigidità e robustezza.

2 base sections pole. The Daitan 7000 is the top of the category Match-Carpa, one step below her sister from which it maintains all the characteristics of light weight, stiffness and strength

### DAITAN 7000 13.00 MT

DESCRIPTION	PCS
DAITAN 7000 13,00mt (9 sect. - Ø 44,70mm)	1
1° Mini Butt 65cm = Put-In Multi Butt (13,00 & 11,50mt)	1
PVC Tubes	2

**CODE: SOLD OUT A**

### DAITAN 7000 11.50 MT

DESCRIPTION	PCS
DAITAN 7000 11,50mt (8 sect. - Ø 42,20mm)	1
1° Mini Butt 75cm = Put-In Multi Butt (11,50 & 10,00mt)	1
PVC Tubes	2

**CODE: CCX93B**

ADDITIONAL MINI EXTENSION-11,50MT  
NOT INCLUDED - 65CM - REVERSE 7° & 6° SECT. - **SOLD OUT**

ADDITIONAL MINI EXTENSION-11,50MT  
NOT INCLUDED - 100CM - REVERSE 5° & 6° SECT. - CODE:CCX93BM1

MULETTO SFT-102 NOT INCLUDED - CODE:CCX83PB

**MULTI BUTT SYSTEM**

## AIRON F66

La denominazione "All Round", trova in queste roubaisienne la sua massima espressione di veridicità. Infatti, nonostante le canne siano corredate con kit da carpa, se su queste saranno montati dei kit match, il loro carattere cambierà a tal punto, da raggiungere un livello d'eccellenza mai visto prima. Nessuna discriminante di pesca per le nuove Airon F66: carpa o match, problema non c'è!! L'eccezionalità del progetto consiste proprio in questo, e cioè RBS nate appositamente per la pesca della carpa, quindi molto robuste, affidabili e rigide, contraddistinte da una leggerezza ed una Down Force, che solo attrezzi di livello superiore possono garantire!

*The "All Round" title, given to these Roubaisienne's is given with the highest regard. In fact despite being equipped with Carp kits, if one fits Match Kits on these poles, their character will change to such an extent that they will reach a level of excellence never seen before. There is no fishing distinction with this new AIRON: Carp or match fishing? There is no difference! The uniqueness of the project lies precisely in this RBS purposely built for carp fishing. So very strong, rigid, reliable, yet so light and counterbalanced with a defined Down Force, that is only found on the higher-level poles.*

### AIRON F66 16.00 MT

DESCRIPTION	PCS
AIRON F-66 16,00mt (10 sect. - Ø 48,50mm)	1
1° Mini Butt 90cm Multi Butt (16,00 + 14,50 + 13,00 + 11,50mt)	1
2° Mini Butt 70cm - Reverse = 6° & 5° sect. (9,50mt & 8,00mt)	1
3° Mini Butt 70cm - Reverse = 4° & 3° sect. (6,50mt & 5,00mt)	1
PVC Tubes	3

CODE: CCX32S

### AIRON F66 13.00 MT

DESCRIPTION	PCS
AIRON F-66 13,00mt (8 sect. - Ø 46,50mm)	1
1° Mini Butt 80cm = Multi Butt (13,00 & 11,50mt)	1
PVC Tubes	2

CODE: CCX32T

ADDITIONAL MINI EXTENSION  
 AIRON F66 13,00MT  
 NOT INCLUDED - 70CM - REVERSE 5° & 4° SECT. - CODE:CCX32TM1



ADDITIONAL MINI EXTENSION  
 AIRON F66 13,00MT  
 NOT INCLUDED - 70CM - REVERSE 4° & 3° SECT. - CODE:CCX32TM2



### AIRON F66 11.50 MT

DESCRIPTION	PCS
AIRON F-66 11,50mt (7 sect. - Ø 44,80mm)	1
1° Mini Butt 80cm = Multi Butt (11,50 & 10,00mt)	1
PVC Tubes	2

CODE: CCX32U

ADDITIONAL MINI EXTENSION  
 AIRON F66 11,50MT  
 NOT INCLUDED - 70CM - REVERSE 5° & 4° SECT. - CODE:CCX32UM1



**MULTI BUTT SYSTEM**

# SPECIAL CARP

RBS

## THOR NX900

XT

RBS All Round con le caratteristiche di maneggevolezza delle nostre canne Match ma con una potenza e una rigidità ineguagliabili. Durante le consuete prove di stress la Thor NX900 ci ha fatto registrare catture di enormi dimensioni.

*This All Round pole combines the handiness of our match poles with a incomparable power and stiffness. During our usual test Thor NX900 impressed us with many huge catches.*

THOR NX900 13.00 MT	
DESCRIPTION	PCS
THOR NX900 13,00mt (8 sect. - Ø 46,50mm)	1
1° Mini Butt 90cm = Put-In Butt (13,00mt)	1
PVC Tubes	1

CODE: CCX94A

ADDITIONAL MINI EXTENSION  
 THOR NX900 13,00MT  
 NOT INCLUDED - 110CM - REVERSE 7° & 6° SECT. - CODE:CCX94AM1

THOR NX900 11.50 MT	
DESCRIPTION	PCS
THOR NX900 11,50mt (7 sect. - Ø 44,70mm)	1
1° Mini Butt 90cm = Put-In Butt (11,50mt)	1
PVC Tubes	1

CODE: CCX95A

ADDITIONAL MINI EXTENSION  
 THOR NX900 13,00MT  
 NOT INCLUDED - 110CM - REVERSE 6° & 5° SECT. - CODE:CCX95AM1

## PLANET CARP

XT

Questa RBS con due basi parallele, è una vera SPECI MAN in grado di sostenere combattimenti con pesci di grandi dimensioni. Testata su carpe di oltre 20kg; la Planet Carp ha dimostrato risultati più che ottimali, anche grazie alle recenti tecnologie impiegate per costruirla.

*This RBS pole with two parallel butts is a true SPECI MAN and it can easily deal with really big fishes. Tested against fishes more than 20kg weight, la Planet Carp showed us all its character and all its power.*

PLANET CARP 13.00 MT	
DESCRIPTION	PCS
PLANET CARP 13,00mt (8 sect. - Ø 46,50mm)	1
1° Mini Butt 800mm = Multi Butt (13,00 & 11,50mt)	1
2° Mini Butt 1150mm - Reverse = 6° & 5° sect. (9,50mt & 8,00mt)	1
PVC Tubes	1

CODE: CCX40T01

PLANET CARP 11.50 MT	
DESCRIPTION	PCS
PLANET CARP 11,50mt (7 sect. - Ø 44,80mm)	1
1° Mini Butt 850mm = Multi Butt (11,50 & 10,00mt)	1
2° Mini Butt 700mm - Reverse = 5° & 4° sect. (8,50mt & 6,00mt)	1
PVC Tubes	1

CODE: CCX40T02

MULTI BUTT SYSTEM

## STINGER CARP

XT

Questa roubaisienne da carpe ha superato brillantemente ogni prova alla quale è stata sottoposta. La Stinger Carp risulta essere un'attrezzo praticamente indistruttibile e adatto a tutti coloro che non cercano mezze misure. Il rapporto qualità prezzo è assolutamente eccezionale.

*This carp pole stands brilliantly all our quality tests. Stinger Carp is an indestructible tool, that will satisfy the most demanding public, and furthermore it comes with a really good quality price ratio.*

### STINGER CARP 11.50 MT

DESCRIPTION	PCS
STINGER CARP 11,50mt (7 sect. - Ø 44,80mm)	1
Mini Butt 95cm = Butt (11,50mt)	1
PVC Tubes	1

CODE: CCX29M01

### STINGER CARP 10.00 MT

DESCRIPTION	PCS
STINGER CARP 10,00mt (6 sect. - Ø 42,40mm)	1
Mini Butt 100cm - Reverse = Butt & 5° sect. (10,00mt & 8,50mt)	1
PVC Tubes	1

CODE: CCX29M02

## CARPA 2.0

XT

Questa RBS con due basi parallele, è una vera SPECI MAN in grado di sostenere combattimenti con pesci di grandi dimensioni. La CARPA 2.0 ha dimostrato risultati più che ottimali, anche grazie alle recenti tecnologie impiegate per costruirla.

*This RBS pole with two parallel butts is a true SPECI MAN and it can easily deal with really big fishes. CARPA 2.0 showed us all its character and all its power.*

### CARPA 2.0 13.00 MT

DESCRIPTION	PCS
CARPA 2.0 13,00mt (8 sect. - Ø 46,50mm)	1
1° Mini Butt 80cm = Multi Butt (13,00 & 11,50mt)	1
2° Mini Butt 115cm - Reverse = 6° & 5° sect. (9,50mt & 8,00mt)	1
PVC Tubes	1

CODE: CCX40S01

### CARPA 2.0 11.50 MT

DESCRIPTION	PCS
CARPA 2.0 11,50mt (7 sect. - Ø 44,80mm)	1
1° Mini Butt 85cm = Multi Butt (11,50 & 10,00mt)	1
2° Mini Butt 70cm - Reverse = 5° & 4° sect. (8,50mt & 6,00mt)	1
PVC Tubes	1

CODE: CCX40S02

**MULTI BUTT SYSTEM**





## ROXY 4000

KT

Canna All round, molto bilanciata, rigida e leggera, da utilizzarsi in qualunque condizione di pesca. Vari i kit opzionali disponibili, sia match che carpa.

*All Round rod, very well balanced, stiff and light, to be used in any different fishing conditions. Different top kits available, both match and carp.*

### ROXY 4000 11.50 MT

DESCRIPTION	PCS
ROXY 4000 11,50mt (8 sect. - Ø 44,70mm)	1
Mini Butt 90cm = Butt (11,50mt)	1
PVC Tubes	1

CODE: CCX96A

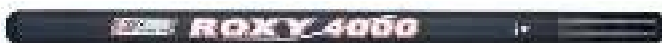

ALL-ROUND  
11.50 MT  
COMPETITION

ROXY 4000

COLMIC

COLMIC

## 9401-X3

KT

Questa canna si pone al top della linea da carpa. Canna Roubaisienne contenuta interamente nella sua base. Questo progetto nasce con la 7401 che ha riscosso un successo assoluto tra gli amanti delle canne della casa Colmic, queste canne si distingueranno per la loro leggerezza abbinata ad una grande rigidità e ad una potenza assoluta. Destinate al pescatore più esigente interessato un attrezzo top che possa esprimere il massimo delle prestazioni e che benefici delle tecnologie più evolute e dei migliori materiali utilizzati per le canne più prestigiose della linea match.

*This rod is at the top of the carp pole series. It is entirely contained in its base. This project was born from the 7401 which had an absolute success between Colmic's addicted. This rods is featured by lightness combined with a great stiffness and a great power. They are destined to the most demanding angler interested in buying a top tackle able to express the maximum performances, thanks to the most evolucional technologies and to the best materials used for the match's rod line.*

### PACK RBS 9401-X3 13,00 MT

DESCRIPTION	PCS
POLE RBS 9401-X3 mt 13,00 (8 sect. - Ø 46,60mm)	1
1° Mini Butt 85cm = 8°sect. (13,00mt)	1
2° Mini Butt 105cm - Reverse = 7° & 6° sect. (11,50mt & 9,80mt)	1
POWER KIT: OVERSIZE K-40 (2,90mt - Top ID 3,20mm) "No Hole"	4
3 sect. "FORCE-4 (K) (1.45mt )	1
PVC Tubes	6
DURO R	1

CODE: C

**SOLD OUT**

### PACK RBS 9401-X3 11,50 MT

DESCRIPTION	PCS
POLE RBS 9401-X3 mt 11,50 (7 sect. - Ø 45,00mm)	1
1° Mini Butt 85cm = 7° sect. (11,50mt)	1
2° Mini Butt 105cm - Reverse = 7° & 6° sect. (11,50mt & 9,80mt)	1
POWER KIT: OVERSIZE K-40 (2,90mt - Top ID 3,20mm) "No Hole"	4
3 sect. "FORCE-4 (K) (1.45mt )	1
PVC Tubes	6
DURO R	1

CODE: C

**SOLD OUT**



# SPECIAL CARP

RBS

**SOLD OUT**

HOLDOLL: RBS XL

## 7401-X3

XT

Canna roubaisienne contenuta nella sua base al vertici di gamma delle canne carpa, realizzata sulla stessa mandrinatura della sorella maggiore la 9401 anche questa canna si distinguerà per la grande potenza, la leggerezza e la rigidità. Perfetta per un pescatore esigente che necessita le massime performance ed un attrezzo maneggevole e affidabile dal peso contenuto che non lo affatichi nelle lunghe sessioni di pesca in carpodromo e catture continuative su carpe di grossa taglia.

*It's a small Roubaisienne rod contained in its base, it's located at the edge of the carpa line rods. It has been realized with the same spindle of its older sister, the 9401, even this is featured by the great power, lightness and reliability. It's suitable for the most demanding anglers which need the maximum performances and a handy-trusty tool, which it doesn't tire during the most longer fishing sessions at the carp drome or simply in the most continuative catches, dealing with the bigger carp.*

### PACK RBS 7401-X3 13,00 MT

DESCRIPTION	PCS
POLE RBS 7401-X3 mt 13,00 (8 sect. - Ø 46,60mm)	1
1° Mini Butt 85cm = 8°sect. (13,00mt)	1
2° Mini Butt 105cm - Reverse = 7° & 6° sect. (11,50mt & 9,80mt)	1
POWER KIT: OVERSIZE K-40 (2,90mt - Top ID 3,20mm) "No Hole"	3
3 sect. "FORCE 4/K" (1,45mt)	1
PVC TUBES	5
HOLDOLL: RBS XL	1
CODE: C	

**SOLD OUT**

### PACK RBS 7401-X3 11,50 MT

DESCRIPTION	PCS
POLE RBS 7401-X3 mt 11,50 (7 sect. - Ø 45,00mm)	1
1° Mini Butt 85cm = 7° sect. (11,50mt)	1
2° Mini Butt 105cm - Reverse = 7° & 6° sect. (11,50mt & 9,80mt)	1
POWER KIT: OVERSIZE K-40 (2,90mt - Top ID 3,20mm) "No Hole"	3
3 sect. "FORCE 4/K" (1,45mt)	1
PVC TUBES	5
HOLDOLL: RBS XL	1
CODE: C	

**SOLD OUT**

PARALLEL EXTENSION 14,50MT

NOT INCLUDED - CODE:CCX87C

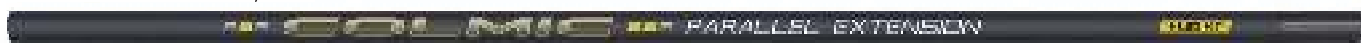

MINI EXTENSION UNI 105CM - 7° & 6° SECT

NOT INCLUDED - CODE:CCX87A



MINI EXTENSION UNI 105CM - 7° & 6° SECT.

NOT INCLUDED - CODE:CCX87A



**SOLD OUT**

**EVOLUTION KARP**

XT

Indistruttibile ma comunque assai maneggevole, la Evo Karp è quanto di meglio un agonista carpa-lago possa chiedere ad un prodotto di questa categoria. L'inarrivabile rapporto tra qualità e prezzo è un ulteriore valore aggiunto, e rende questa roubaissienne ancora più esclusiva sotto ogni punto di vista.

*An indestructible pole but still very maneuverable, the Evolution Karp is the best a competition commercial fisherman can ask for in this product category. The unbelievable price/quality ratio is an added value to this pole, making it even more exclusive under any point of view.*

**EVOLUTION KARP 10.00 MT**

DESCRIPTION	PCS
EVOLUTION KARP 10.00mt (7 sect. - Ø 41,00mm)	1
Mini Extender	1
PVC tubes	1

CODE: C

**SOLD OUT**



**SOLD OUT**

**CARP RAIDER**

XT

Questa rbs è quanto di meglio possiate reperire sul mercato attuale, in ambito di attrezzi specifici per la pesca estrema. Grande robustezza, rigidità e bilanciatura, sono le caratteristiche principali della CARP RAIDER. Un rapporto qualità/prezzo sicuramente ineguagliabile, la rende oltremodo unica nella sua categoria.

*This RBS is the best you can ever find inside the actual fishing tools market for the extreme fishing. It is featured by a great robustness, rigidity and balance. An incomparable value quality over price ensures its uniqueness in its category.*

**PACK CARP RAIDER 11,50 MT**

DESCRIPTION	PCS
POLE RBS CARP RAIDER - 11,50mt (7 sect. - Ø 45,30mm)	1
Mini Butt 80cm = 7° (11,50mt)	1
Mini Butt 105cm = 6° (10,00mt)	1
POWER KIT: HM40-ST (2,95mt - Top ID 2,70mm) - "No Hole"	2
POWER KIT "HYPER-30" (2,95mt - Top ID 2,70mm) "No Hole"	1
PVC Tubes	4
HOLDALL RACE	1

CODE: CCX90B

**PACK CARP RAIDER 10,00 MT**

DESCRIPTION	PCS
POLE RBS CARP RAIDER - 10,00mt (6 sect. - Ø 42,90mm)	1
Mini Butt 105cm = 6° (10,00mt)	1
POWER KIT: HM40-ST (2,95mt - Top ID 2,70mm) - "No Hole"	1
POWER KIT "HYPER-30" (2,95mt - Top ID 2,70mm) "No Hole"	1
PVC Tubes	3
HOLDALL RACE	1

CODE: C

**SOLD OUT**



# SPECIAL CARP

RBS

## KARPER X3

KT

SPECIMEN in grado di sostenere i combattimenti più ardui con pesci di grande mole e attrezzature al limite dell'impossibile. Ebbene, possiamo dire con orgoglio che la Karper X3 è la discendente diretta di un'antenata piuttosto giovane, ma con il beneficio di aver ottenuto una maggiore rigidità ed equilibratura, a parità di robustezza e prestazioni.

*SPECIMEN able to support the hardest struggles with great size fishes and equipment at the edge of the impossible. Therefore, we can proudly claim that this Karper X3 is the direct descending of a young ancestor, but with the advantage to gain a mayor robustness and rigidity in equity robustness and performances.*

### PACK RBS KARPER X3 10,00MT

DESCRIPTION	PCS
POLE KARPER X3 10,00mt (6 sect. - Ø 41,00mm)	1
Mini Butt 110cm - Reverse 6° & 5° (10,00mt & 9,20mt)	1
POWER KIT KARPER 30" (2,90mt) "Hole"	1
PVC TUBES	2
CODE: C	

**SOLD OUT**



**SOLD OUT**



**SPECI CARP**

Potente, affidabile e indistruttibile, questa rbs nasce per le pesche più gravose nei carpodromi.

*Powerful reliable and indestructible, these Roubaisienne pole have been conceived to address the most helty fish in the carp fisheries.*

SPECI CARP 10,00 MT	
DESCRIPTION	PCS
SPECI CARP 10,00mt	1
Mini Ext. 110cm - (10,00mt)	1

CODE: CCXX42

ADDITIONAL MINI EXTENSION

NOT INCLUDED - 70CM - REVERSE 4° & 5° (11,50MT) - CODE:CCXX42A



**SOLD OUT**

**GEMINI 500**

XT

Roubaisienne destinata agli specimen più esigenti. Canna da carpa pura è veramente indistruttibile, e sarà una fedele alleata nei combattimenti più ardui, senza venir meno alle caratteristiche di prontezza che questa tecnica spesso richiede.

*A pole designed for the more exigent specimen fishermen, this carp pole rod is really indestructible, will be a trustable alley in the heaviest fights, without missing the prompt actions and fast response required in this fishing technique.*

GEMINI 500 11,50 MT	
DESCRIPTION	PCS
GEMINI 500 11,50mt (sect. - Ø 44,00mm)	1
Mini Ext. 110cm - (10,50mt)	1
Velvet	1

**SOLD OUT**

CODE: C

## SPIRIT CARP



E' la roubaisienne da carpa molto sottile con un diametro alla base di 37,2mm. Rigida, sottile e leggera è prodotto in carbonio alto modulo che la rende praticamente indistruttibile.

*With a base diameter of 37.2mm Spirit is a very thin RBS pole. Stiff, thin and light it is made in high module carbon a material that make Spirit Carp a practically indestructible.*

### SPIRIT CARP 10,00 MT

DESCRIPTION	PCS
SPIRIT CARP 10,00mt (8 sect. - Ø 35,70mm)	1
Mini Extension 10,00mt (100cm)	1
Velvet Cloth Bag	1

CODE: CCX14X



## FORCE H1 SLIM



La Force H-1 è la roubaisienne più sottile di tutta la gamma. Studiata appositamente per sopportare le sollecitazioni più gravose, la Force H-1 è in grado di sostenere ogni genere di prova. L'impiego di ottimi materiali e la calciatura ultra slim conferiscono a quest'attrezzo una leggerezza ed una maneggevolezza davvero eccellenti, rendendola quindi adatta anche all'utilizzo in canale con assetti più light.

*The Force-H1 pole is the slimmest of the whole assortment. Expressly developed for heavy duty fishing, the Force-H1 can handle any heavy duty fishing situation. The use of high quality materials and the slim profile make this pole exceptionally light and maneuverable, will perfectly perform also in canal fishing on lighter rigs.*

### FORCE H1 SLIM 10,00 MT

DESCRIPTION	PCS
FORCE H1 SLIM 10,00mt (8 sect. - Ø 35,70mm)	1
Mini Extension 10,00mt (100cm)	1
Velvet Cloth Bag	1

CODE: CCX14XA

## BETA-SM

Questa roubaisienne Colmic, è stata testata in anteprima dai nostri specimen anglosassoni e francesi, direttamente nei loro carpodromi e bacini naturali. Le prove di stress alle quali è stata sottoposta, sono state estreme e non sono mancati i combattimenti con pesci di 15 kg ed oltre.

*This Colmic pole has been tested by our new French and British specimen pole fishermen, directly in their carp fisheries, carpodromes and natural venues. The stress tests the pole has been subject have been the more extreme ones with fight against fish of over 15 kgs and over !*

### BETA 8,50 MT

DESCRIPTION	PCS
BETA 8,50mt (5 sect. - Ø 38,20mm)	1
Mini 1000mm - Reverse: 8,50mt & 7,60mt	1
Velvet Cloth Bag	1

CODE: CCXX37



## BATCARP

RBS corta, studiata appositamente per la pesca delle grosse carpe sotto sponda. Le peculiarità salienti di quest'attrezzo, sono un'estrema potenza, associata ad una affidabilità oltre la norma, anche nel caso in cui si utilizzino elastici e nylon di dimensioni eccezionali. Indistruttibile!

*Margin pole rod, expressly developed for big carp fishing on the hedge. The main feature of this pole are strongness matched to a great reliability, even using very large diameters nylons and big elastics. An indestructible pole. Equipped by reversible mini butts, usable on the different sections.*

### BAT CARP

CODE	DESCRIPTION
CC9605A	BATCARP 9,00mt (Mini Butt 80cm)
CC9605B	BATCARP 8,00mt (Mini Ext. Reverse 8,00 - 6,50mt / 80cm)
CC9605C	BATCARP 6,50mt (Mini Ext. Reverse 6,50 - 5,00mt / 80cm)

## C-09

Questa mini RBS, nasce per la pesca di grosse carpe sotto sponda. Caratteristiche principali, sono l'estrema potenza ed affidabilità anche pescando con elastici e nylon sostenuti. Praticamente indistruttibile!!

*These mini Roubaisienne poles were conceived for the bank fishing of big carp. Their most striking features are extreme power and reliability, even when fishing with large-size elastics and nylons. It is, in effect, practically indestructible!!*

### C09 - SPECIAL CARP

CODE	DESCRIPTION
CC9601A	C-09 SPECIAL CARP 9,00mt (Mini Butt 80cm)
CC9601B	C-09 SPECIAL CARP 8,00mt (Mini Ext. Reverse 80cm 8,00 > 6,50mt)
CC9601C	C-09 SPECIAL CARP 6,50mt (Mini Ext. Reverse 80cm 6,50 > 5,00mt)



# MINI - EXTENSION

RBS

## PARALLEL EXTENSION

### PARALLEL EXTENSION 14,50MT

CODE	COMPATIBILITY
CCX87C	QUASAR (13,00 MT) - EVO FIGHT (13,00 MT) - 6401 (13,00 MT) 7401 (13,00 MT) - 7401 X3 (13,00 MT) - 9401 X3 (13,00 MT)

## EXTRA MINI

### EXTRA MINI 105CM 6° - 7°

CODE	COMPATIBILITY
CCX87A	QUASAR (13,00 MT) - EVO FIGHT (13,00 MT) - 6401 (13,00 MT) 7401 (13,00 MT) - 7401 X3 (13,00 MT) - 9401 X3 (13,00 MT)

### EXTRA MINI 105CM 4° - 5°

CODE	COMPATIBILITY
CCX87B	QUASAR (11,50 MT) - EVO FIGHT (11,50 MT) - 6401 (11,50 MT) 7401 (11,50 MT) - 7401 X3 (11,50 MT) - 9401 X3 (11,50 MT)

**SOLD OUT**



PARALLEL EXTENSION

## EXTRA MINI

### EXTRA MINI SERIES 01 - 02 - 02A - 03

CODE	DESCRIPTION	DIM.	COMPATIBILITY
CCXM001	9°sect - Series 03 -13,00mt	65cm	9933 - 9033 - 8033 -7733
CCXM002	7° & 6°sect - Series 03 -13,00mt	70cm	9933 - 9033 - 8033 -7733
CCXM003	9°sect - Series 02 - 13,00mt	65cm	DAITAN 9000 - DAITAN 7000 - 8022 - 6922 - 5922 - 7022 - 6622 7322 - 7522
CCXM004	7° & 6°sect - Series 02 - 13,00mt	70cm	DAITAN 9000 - DAITAN 7000 - 8022 - 6922 - 5922 - 7022 - 6622 7322 - 7522
CCXM005	8°sect - Series 01 -13,00mt	90cm	EVO FIGHT - QUASAR - 7401 - 6401 - ROXY4000 - CARP RIDER THOR NX900 - 9401 X3 - 7401 X3
CCXM006	7° & 6°sect - Series 01 - 13,00mt	110cm	EVO FIGHT - QUASAR - 7401 - 6401 - ROXY4000 - CARP RIDER THOR NX900 - 9401 X3 - 7401 X3
CCXM007	8°Match or 7°Carpa Series 01 -11,50mt	90cm	EVO FIGHT - QUASAR - 7401 - 6401 - ROXY4000 - CARP RIDER THOR NX900 - 9401 X3 - 7401 X3
CCXM008	7° & 6°Match or 6° & 5°Carpa Series 01 -11,50mt	110cm	EVO FIGHT - QUASAR - 7401 - 6401 - ROXY4000 - CARP RIDER THOR NX900 - 9401 X3 - 7401 X3
CCXM009	5° & 4°Match or 4° & 3°Carpa Series 01 - 02 - 03	70cm	For RBS Serie 01- 02 - 03
CCXM010	8°sect - Series A02 -13,00mt	80cm	AIRON F66 - AIRON F55 - AIRON F44 - AIRONF33 PLANET CARPA - CARPA 2.0
CCXM011	6° & 5°sect - Series A02 -13,00mt	115cm	AIRON F66 - AIRON F55 - AIRON F44 - AIRONF33 PLANET CARPA - CARPA 2.0
CCXM012	4° & 3°sect - Series A02 -13,00mt	70cm	AIRON F66 - AIRON F55 - AIRON F44 - AIRONF33 PLANET CARPA - CARPA 2.0
CCXM013	7°sect - Series A02 -11,50mt	80cm	AIRON F66 - AIRON F55 - AIRON F44 - AIRONF33 PLANET CARPA - CARPA 2.0
CCXM014	5° & 4°sect - Series A02 -11,50mt	70cm	AIRON F66 - AIRON F55 - AIRON F44 - AIRONF33 PLANET CARPA - CARPA 2.0

## MARGIN PREDATOR

Mini roubaisienne appositamente studiata per la pesca dei grossi ciprinidi nell'immediato sotto riva. Questa short pole è dotata di ceramic slot per la regolazione della tensione dell'elastico a mano ed è rinforzata su tutte le zone d'innesto. Un attrezzo davvero indistruttibile, destinato alla pesca estrema in competizione o a quella per puro diletto in laghi o carpodromi.

*The Margin Predator designed for the Cyprinide's family in the underneath waterside. The "short" pole rod is equipped by slot ceramic to adjust by hand the elastic's tension and all the graft's areas are reinforced. This rod is indestructible suitable for the extreme competitions and for leisure fishing as well both at lakes or carpodromes. Our experts have tested it.*

MARGIN PREDATOR	
CODE	DESCRIPTION
CAMA90A	Margin PREDATOR 6,00mt Mini Ext. Reverse 80cm: 2°- 3° (3,60 & 5,20mt)

KIT MARGIN PREDATOR	
CODE	DESCRIPTION
CAMA90B	Top Kit 2 sect. (2,90mt) - With RING
CAMA90C	Top Kit 2 sect. (2,90mt) - No RING



## SPONDA HH

Questa mini roubaisienne nata specificatamente per la pesca sotto sponda in carpodromo è caratterizzata da una struttura ibrida composta da 3 pezzi telescopici, 2 ad innesti e 2 mini prolunghe. Tale composizione le permette di affrontare ogni situazione di pesca alle carpe di taglia nell'immediato sotto sponda. Indistruttibile ed affidabile.

*Margin pole especially conceived for the fisheries. It's featured by an hybrid structure composed by 3 telescopic sections, 2 put in sections and 2 mini-extensions. This composition makes it able to face every situation dealing with the underneath bank carps fishing. Indestructible and reliable margin pole.*

SPONDA HH	
CODE	DESCRIPTION
CASP60A	Sponda HH 7,00mt + Mini Ext. 105 cm : 5° (7,00mt) + Mini Ext. Reverse 80 cm: 3°- 4° (3,90 - 5,20mt)

KIT SPONDA HH	
CODE	DESCRIPTION
CASP60B	Top Kit 3 sect. (3,10mt) - With RING
CASP60C	Top Kit 3 sect. (3,10mt) - No RING

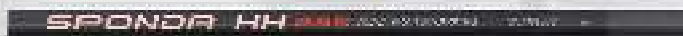

# MARGIN POLES

## SPECI PLUS

XT

Questa RBS di 5,50mt ideale per la pesca in carpodromo sotto sponda è composta da 7 sezioni: Base (120cm) + 1° (75cm) + 2° (75cm) + 3° (75cm) + 4° (75cm) + 5° (80cm) + 6° (85cm), misure perfette per seguire il comportamento delle carpe che durante la competizione si allontanano molto gradualmente. Questa RBS leggerissima, rigida e indistruttibile ci permette di pescare con terminali "enormi" 0,25-0,30-0,35 senza problemi.

*This 5,50mt is the ideal for fishing in carpodrome (commercial lake) just under the lake shore. Specì Plus is composed by 7 sections, : Butt (120cm) + 1° (75cm) + 2° (75cm) + 3° (75cm) + 4° (75cm) + 5° (80cm) + 6° (85cm), the perfect sizes for following the carps close, when they slowly move away during competitions. This RBS is very light, rigid and indestructible and it allows to fish with huge hook lengths (0,25-0,30-0,35) without any problem.*

SPECI PLUS 5,50MT	
DESCRIPTION	PCS
SPECI PLUS 5,50mt	1
Top kit 4 sec. + PVC tube	1
Top kit 5 sec. + PVC tube	1
Extra PVC tube	1
Rodhall (SOLD OUT)	1
CODE: C	

TOP KITS	
CODE	DESCRIPTION
CASP53A	Top kit 4 sec. + PVC tube
(SOLD OUT)	Top kit 5 sec. + PVC tube

SECTION	
CODE	DESCRIPTION
(SOLD OUT)	3° Sec. SPECI PLUS w/Reinf.
(SOLD OUT)	4° Sec. SPECI PLUS w/Reinf.



## ROYAL S-100

XXX

SUPER LIGHT - ACTION 3

Nasce per essere utilizzata per la pesca light. Indicata per terminali sottili e zavorre leggere.

*So even if originally conceived for light fishing. Ideal when used with very thin hook lengths and light tackles.*

CODE	Length (m)	Casting W. (gr)	cl.Length (cm)	Weight (gr)	Diameter R/S (mm)	Sections
CAR001A	6,00	10	145	200	19,50	6
CAR001B	7,00	10	147	270	21,50	7



## ROYAL S-200

XXX

STRONG - ACTION 1

Ideale per la pesca a lunghe distanze con grammature medio pesanti. Ottima bilanciatura.

*Ideal for fishing at long distances with medium heavy weights. Excellent balance.*

CODE	Length (m)	Casting W. (gr)	cl.Length (cm)	Weight (gr)	Diameter R/S (mm)	Sections
CAR002A	6,00	20	137	227	22,30	6
CAR002B	7,00	20	138	300	24,00	7
CAR002C	8,00	20	139	373	25,80	8



Series: YGS



LEG: Medium  
STONE: Sic  
FRAME COLOR: Frosted Gun Smoke

CAXIN  
REEL SEAT



# BOLO HIGH PERFORMANCE

CANNE - RODS

## FIUME 110-S

XXYT

SUPER LIGHT - ACTION 3

Molto bilanciata è ideale per la pesca con grammature leggere e terminali sottili.

*Very balanced, it is ideal for fishing with thin hook lengths and light tackles.*

CODE	Length (mt)	Casting W. (gr)	cl.Length (cm)	Weight (gr)	Diameter R/S (mm)	Sections
CAF191A	6,00	11	148	210	19,50	6
CAF191B	7,00	11	149	270	21,60	7



Series: Y-D1

ULTRA LIGHT



LEG: Medium  
STONE: Stainless Steel  
FRAME COLOR: Frosted Gun Smoke



CAXIN REEL SEAT



## FIUME 160-S

XXYT

MEDIUM - ACTION 2

Leggera e bilanciata è ideale per la pesca in passata e in mare con terminali medio sottili.

*Light and balanced, the rod is perfect for river or saltwater fishing, with light hook lengths.*

CODE	Length (mt)	Casting W. (gr)	cl.Length (cm)	Weight (gr)	Diameter R/S (mm)	Sections
CAF190A	5,00	16	141	150	18,70	5
CAF190B	6,00	16	144	225	21,00	6
CAF190C	7,00	16	145	310	23,50	7
CAF190D	8,00	16	147	435	26,00	8



Series: Y-D1

ULTRA LIGHT



LEG: Medium  
STONE: Stainless Steel  
FRAME COLOR: Frosted Gun Smoke



CAXIN REEL SEAT



## FIUME 180

XXYT

MEDIUM STRONG - ACTION 2

Leggera e bilanciata è ideale per la pesca in passata e in mare, con terminali medio sottili.

*Light and balanced, the rod is perfect for river or saltwater fishing, with light hook lengths.*

CODE	Length (mt)	Casting W. (gr)	cl.Length (cm)	Weight (gr)	Diameter R/S (mm)	Sections
CAF182A	5,00	18	141	155	18,60	5
CAF182B	6,00	18	142	220	21,60	6
CAF182C	7,00	18	146	295	23,50	7
CAF182D	8,00	18	148	375	25,80	8



Series: YGS

ULTRA LIGHT



LEG: Medium  
STONE: Sic  
FRAME COLOR: Frosted Gun Smoke



CAXIN REEL SEAT





**FIUME NX 25GR**

*XXYT*

STRONG - ACTION 1

Estremamente leggera è ideale per la competizione e i combattimenti con pesci di grossa e media taglia.

*Lightweight competition rod especially suited to battle medium and big size fish species.*

CODE	Length (mt)	Casting W. (gr)	cl.Length (cm)	Weight (gr)	Diameter R/S (mm)	Sections
CAF184A	5,00	25	135	180	20,15	5
CAF184B	6,00	25	136	245	23,60	6
CAF184C	7,00	25	138	320	25,30	7
CAF184D	8,00	25	140	415	26,90	8

Series: YGS



LEG: Medium  
STONE: Sic  
FRAME COLOR: Frosted Gun Smoke



**CAXIN**  
REEL SEAT



Series: XM

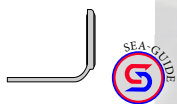

LEG: Micro Guides  
STONE: Sic  
FRAME COLOR: Gun Smoke



Series: XY



LEG: Short  
STONE: Sic  
FRAME COLOR: Gun smoke



**CAXIN**  
REEL SEAT



**FIUME NX 35GR**

*XXYT*

SUPER STRONG - ACTION 1

Ideale per la pesca a lunghe distanze con grammature medio pesanti. Ottima bilanciatura.

*Ideal for fishing at long distances with medium heavy weights. Excellent balance.*

CODE	Length (mt)	Casting W. (gr)	cl.Length (cm)	Weight (gr)	Diameter R/S (mm)	Sections
CAF185A	5,00	35	150	205	22,60	5
CAF185B	6,00	35	152	275	24,30	6
CAF184C	7,00	35	155	370	27,20	7
CAF184D	8,00	35	155	475	30,70	8



# BOLO HIGH PERFORMANCE

## FOCE NX-300

KKT

MEDIUM LIGHT - ACTION 1

Canna bolognese di estrema potenza e bilanciatura, ideale per chi cerca un oggetto veramente affidabile in tutte le situazioni, anche le più estreme. Perfetta per la pesca in passata con terminali medio sottili.

*Very powerful and balanced Bolognese rod, ideal for anyone looking for an article that is genuinely reliable in all situations, even the most extreme. Perfect for river fishing with light hook lengths.*

CODE	Length (mt)	Casting W. (gr)	cl.Length (cm)	Weight (gr)	Diameter R/S (mm)	Sections
CAF050A	9,00	12	152	482	31,50	8
CAF050B	10,00	12	156	606	34,50	9
CAF050C	11,00	12	158	768	38,10	10
CAF050D	12,00	12	161	950	41,90	11



Series: Y-D1

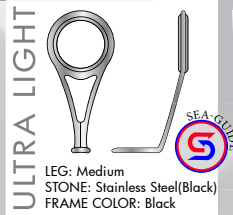

CAXIN REEL SEAT



## FOCE NX-100

KT

MEDIUM - ACTION 2

Canna ideale per la pesca in passata con terminali medio sottili.

*The rod is perfect for river fishing with light hook lengths.*

CODE	Length (mt)	Casting W. (gr)	cl.Length (cm)	Weight (gr)	Diameter R/S (mm)	Sections
CAF051A	9,00	12	160	440	31,00	8
CAF051B	10,00	12	162	620	34,50	9
CAF051C	11,00	12	164	795	38,10	10



Series: Y-D1

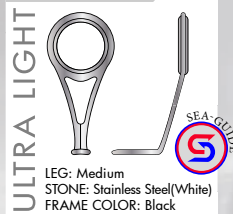

ALPS REEL SEAT



**REVOLT** XT

MEDIUM LIGHT - ACTION 2

Top di gamma è eccezionale per passata in fiume a grosse prede o per la pesca dalla scogliera con mare in scaduta.

*This rod is perfect for river fishing for big fish or saltwater fishing from shore with decreasing seas.*

Series: YGS



LEG: Medium  
STONE: Sic  
FRAME COLOR: Black



**CAXIN**  
REEL SEAT



CODE	Length (mt)	Casting W. (gr)	cl.Length (cm)	Weight (gr)	Diameter R/S (mm)	Sections
CARE100A	5,00	20	144	195	22,00	5
CARE100B	6,00	20	144	280	24,40	6
CARE100C	7,00	20	145	380	26,90	7



**HORIZON** XT

MEDIUM STRONG - ACTION 2

Canna bolognese bilanciata, leggera, sottile e reattiva, ideale per la pesca a distanza, o in tutte quelle circostanze dove sia richiesta una certa rigidità e capacità di gestire terminali di diametro anche sostenuto.

*It is a balanced, thin, light and reactive Bolognese rod for distance fishing and in all the circumstances where it takes a certain robustness and a certain skills to handle the diameter tips sometimes heavy.*

Series: YGS



LEG: Medium  
STONE: Sic  
FRAME COLOR: Black

CODE	Length (mt)	Casting W. (gr)	cl.Length (cm)	Weight (gr)	Diameter R/S (mm)	Sections
CAH050A	5,00	25	143	210	20,00	5
CAH050B	6,00	25	144	283	22,20	6
CAH050C	7,00	25	145	410	25,50	7



Series: XM

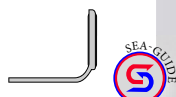

LEG: Micro Guides  
STONE: Sic  
FRAME COLOR: Gun Smoke



Series: XY

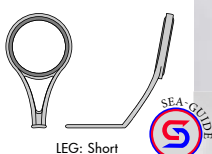

LEG: Short  
STONE: Sic  
FRAME COLOR: Frosted Gun Smoke



**CAXIN**  
REEL SEAT



**EMPERIA** XT

MEDIUM STRONG - ACTION 3

Canna robusta ed affidabile è particolarmente indicata per la pesca in velocità nelle competizione trota lago. Emperia 6,00mt: blocco a 5 mt. (13 anelli) / Emperia 5,00mt: senza blocco (12 anelli)

*Robust and reliable rod, it is particularly suitable for fishing in speed in trout lake competition.. Emperia 6,00mt: adjustable block at 5 mt. (13 anelli) / Emperia 5,00mt: without block (12 anelli)*

CODE	Length (mt)	Casting W. (gr)	cl.Length (cm)	Weight (gr)	Diameter R/S (mm)	Sections
CAEM30A	5,00	20	144	238	21,80	5
CAEM30B	5,00-6,00	20	146	333	24,10	6





# COLMIC HIGH POWER

CANNE - RODS

## POTENZA PRO

KT

SUPER STRONG - ACTION 2

Canna polivalente, ideale per le pesche estreme sia in mare che in acqua dolce con finali al massimo di 25mm.

*Multipurpose heavy duty bolo rod suitable for both fresh and salt water fishing, maxium hook lenght diameter 0,25 mm.*

CODE	Length (mt)	Casting W. (gr)	cl. Length (cm)	Weight (gr)	Diameter R/S (mm)	Sections
CAPO90A	5,00	80	140	263	21,00	5
CAPO90B	6,00	80	142	390	23,90	6
CAPO90C	7,00	80	144	550	27,60	7

Series: YGS



LEG: Medium  
STONE: Sic  
FRAME COLOR: Gun Smoke

LIFT-UP 5KG



SOLD OUT



## POWER FIGHTING

KT

SUPER STRONG - ACTION 2

Canna con un casting da 100 gr che permette lanci a lunghe distanza e un riserva di potenza in fase di combattimento con pesci di grossa taglia.

*Rods with a 100 g casting weight that allows even long-distance casts and a power reserve for the battle phase even with big fish.*

CODE	Length (mt)	Casting W. (gr)	cl. Length (cm)	Weight (gr)	Diameter R/S (mm)	Sections
CAPO18	5,00	100	140	330	24,00	5
CAPO18A	6,00	100	142	550	28,15	6
CAPO18B	7,00	100	144	750	32,00	7

SOLD OUT

Series: OS

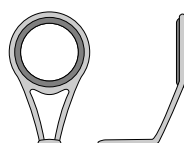

LEG: Short  
STONE: Simil Sic  
FRAME COLOR: Black

LIFT-UP 9KG





**SKYDEK**

X5

15gr - MEDIUM - ACTION 3

Ideale per pesci di grossa taglia sia per le acque interne che in mare.  
*Ideal rod for big fish for both, inside waters and sea.*

CODE	Length (m)	Cast (m)	Weight (gr)	Diameter R/S (mm)	Sections
CASK50A	4,00	15,00	160	16,60	4
CASK50B	5,00	15,00	230	20,15	5
CASK50C	6,00	15,00	323	20,60	6

**SOLD OUT**

25gr - STRONG - ACTION 2

Canna ideale per pesci di grossa taglia con terminali robusti e per lanci a media distanza.

*Ideal rod for big fish with robust terminals tackles for medium distance casting.*

CODE	Length (m)	Cast (m)	Weight (gr)	Diameter (mm)	Sections
CASK51A	4,00	20,00	176	18,90	4
CASK51B	5,00	20,00	270	22,70	5
CASK51C	6,00	20,00	415	26,30	6

**SOLD OUT**

Series: YGS



LEG: Medium  
STONE: Simil Sic  
FRAME COLOR: Black



**SOLD OUT**

**SOLD OUT**

**FUTURA 150**

X5

MEDIUM LIGHT - ACTION 3

Leggera, maneggevole e robusta, è una canna che si presta agli impieghi più svariati: Porto, lago, scogliera, fiume o canale.

*Light, easy to handle and very strong, the Futura is a rod that is suited for multiple uses: ports, lakes, reefs, rivers, or canals.*

CODE	Length (m)	Cast (m)	Weight (gr)	Diameter R/S (mm)	Sections
CAFU60A	4,00	15,00	180	17,00	4
CAFU60B	5,00	15,00	245	20,50	5
CAFU60C	6,00	15,00	350	23,50	6

**SOLD OUT**

Series: YGS



LEG: Medium  
STONE: Simil Sic  
FRAME COLOR: Gun Smoke



## SYSON

X5

STRONG - ACTION 2

Canna bolognese ideale per chi si avvicina a questa tecnica e cerca la qualità unita all'affidabilità.

*The Syson is a "entry level" Bolognese, very suitable for beginners of this particular technique who looking for quality and reliability.*

CODE	Length (mt)	Casting W. (gr)	cl.Length (cm)	Weight (gr)	Diameter R/S (mm)	Sections
CASY65A	4,00	18	130	190	18,25	4
CASY65B	5,00	18	131	310	23,20	5



Series: OS

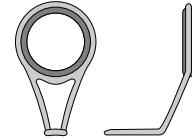

LEG: Short  
STONE: Simil Sic  
FRAME COLOR: Black

## REMAKE

STRONG - ACTION 2

Canna in materiale composito robustissima ed affidabile, perfetta per i principianti. Prodotto economico ma dalle buone prestazioni. Perfetta per le acque dolci o salate ed il carpodromo.

*Strong and durable composite material telescopic rods, perfect for the beginners, but featured by good performances. It is perfect either as fresh either as salt-water fishing and fisheries.*

W/GUIDES

CODE	Length (mt)	cl.Length (cm)	Weight (gr)	Diameter R/S (mm)	Sections
CARE30A	3,00	114	150	18,00	3
CARE30B	4,00	116	255	23,00	4
CARE30C	5,00	116	410	27,30	5

NO GUIDES

CODE	Length (mt)	cl.Length (cm)	Weight (gr)	Diameter R/S (mm)	Sections
CARE31A	3,00	114 cm	120	18,40	3
CARE31B	4,00	114 cm	220	23,80	4
CARE31C	5,00	114 cm	330	27,80	5

# MICRO GUIDES

## EPICUS XT

ULTRA LIGHT - ACTION 4

Canna deale per la pesca in passata e in mare, con terminali sottili.

*The rod is perfect for river or saltwater fishing, with light hook lengths.*

Series: XDM



CODE	Length (mt)	C.W.	cl.Length (cm)	Weight (gr)	Diameter (mm)	Sections
CAEP30A	4,50	1,5 - Light	115	150	15,40	4
CAEP30B	5,30	1 - Ultra Light	116	206	19,90	5
CAEP30C	5,30	1,5 - Light	116	228	20,10	5
CAEP30D	5,30	2 - Medium	117	259	20,00	5



# STORIONE

## STOR XT

SUPER STRONG - ACTION 1

Telescopica "a tutto tondo" per la pesca dei grandi predatori, con una potenza di lancio sbalorditiva che, nonostante la sua forza, risulterà molto maneggevole ed equilibrata.

*All-Round telescopic rod for big predators fishing with a surprising power launching too, despite of its strength, it will result very handily and balanced.*

CODE	Length (mt)	Casting W. (gr)	cl.Length (cm)	Weight (gr)	Diameter R/S (mm)	Sections
CAST70A	4,20	300	157	540	30	4

Series: MN



STONE: Simil Sic  
FRAME COLOR: Black



# TELESCOPIC POLE

## EXTREME

XXT

ULTRA LIGHT - ACTION 2

Canna fissa destinata ad un pubblico che pretende sempre il meglio ed il massimo che la tecnologia offre sul mercato, ha una bilanciatura senza uguali e ad una leggerezza estrema.

*Fixed rod aimed at a public that always expects the best and the maximum that technology has to offer on the market, this rod combines an unrivalled balance and an extreme lightness.*

CODE	Length (m)	cl.Length (cm)	Weight (gr)	Diameter (mm)	Sections
CAEX71A	5,00	141	115	20,80	5
CAEX71B	6,00	141	166	22,40	6
CAEX71C	7,00	141	212	24,10	7
CAEX71D	8,00	141	282	26,90	7
CAEX71E	9,00	141	380	29,20	8
CAEX71F	10,00	141	500	31,70	9
CAEX71G	11,00	141	612	33,80	10



## ARROW

XT

MEDIUM STRONG - ACTION 1

Affidabile e allo stesso tempo leggera e maneggevole, trova il suo impiego ottimale pescando anche con i terminali più sottili.

*Reliable, light and easily maneuverable is perfect for thin hook length and delicate fishing.*

CODE	Length (m)	cl.Length (cm)	Weight (gr)	Diameter (mm)	Sections
CAAR60A	5,00	140	153	19,70	5
CAAR60B	6,00	140	218	23,80	6
CAAR60C	7,00	140	322	27,25	7
CAAR60D	8,00	140	410	29,40	7
CAAR60E	9,00	140	499	32,10	8



## GIGHEN X5

X5

MEDIUM STRONG - ACTION 2

Telescopica affidabile al 100%, viene montata con vetta tubolare e le sue sezioni rinforzate con spire di carbonio la rendono adatta sia per la pesca in fiume che per la pesca in mare.

*Telescopic rod 100% reliable, features a tubular tip and cross reinforced carbon, perfect for both river and saltwater fishing.*

CODE	Length (m)	cl.Length (cm)	Weight (gr)	Diameter (mm)	Sections
CAG151A	4,00	135	140	17,10	4
CAG151B	5,00	135	210	20,50	5
CAG151C	6,00	135	278	22,80	6
CAG151D	7,00	135	375	26,00	7
CAG151E	8,00	135	486	29,10	8

Carbon Spiral



**SOLD OUT**

# HIGH PERFORMANCE

## FOLGORE

X5

STRONG - ACTION 3

Canna all-round, ideale per essere utilizzata come fissa classica, montata con elastico oppure anellata per l'utilizzo a bolognese.

*The all-round rod may be used as a classic pole without guides or may be mounted with guides for Bolognese fishing.*

CODE	Length (m)	cl.Length (cm)	Weight (gr)	Diameter (mm)	Sections
CAFO02	4,00	126	140	17,40	4
CAFO02A	5,00	126	210	20,50	5
CAFO02B	6,00	126	278	23,50	6
CAFO02C	7,00	126	375	26,40	7

**SOLD OUT**



# TELESCOPIC POLE

## MAXIS

X5

MEDIUM STRONG - ACTION 2

Telescopica all-round viene montata con vetta tubolare e le sue sezioni rinforzate con spire di carbonio la rendono adatta sia per la pesca in fiume che per la pesca in mare ai cefali.

*All-round telescopic rod, features a tubular tip and cross reinforced carbon, perfect for both river and saltwater fishing for mullets and big specimens.*

CODE	Length (m)	cl. Length (cm)	Weight (kg)	Diameter (mm)	Sections
CAMA80A	4,00	135	486	17,10	4
CAMA80B	5,00	135	486	17,50	5
CAMA80C	6,00	135	486	17,80	6
CAMA80D	7,00	135	486	18,00	7
CAMA80E	8,00	135	486	18,10	8

**SOLD OUT**

Carbon Spiral



## POLARIS

X5

STRONG - ACTION 3

Canna all-round, ideale per essere utilizzata come fissa classica, montata con elastico oppure anellata per l'utilizzo a bolognese.

*The all-round rod may be used as a classic pole without guides or may be mounted with guides for Bolognese fishing.*

CODE	Length (m)	cl. Length (cm)	Weight (kg)	Diameter (mm)	Sections
CAPO12A	5,00	126	510	25,50	5
CAPO12B	6,00	126	510	26,50	6
CAPO12C	7,00	126	510	26,00	7
CAPO12D	8,00	126	510	31,20	8

**SOLD OUT**



**SOLD OUT**

**SOLD OUT**



## EMPEROR PRO

LIGHT - ACTION 1

Serie di canne nate e concepite per la pesca in velocità di alborelle e altri piccoli pesci, ideali per gli agonisti che si vogliono un prodotto dalle prestazioni superiori.

*Rod series conceived for bleaks and other small size fishes speed fishing. They are suitable either as experts of this technique either as those agonists that desired an high performances product.*

CODE	Length (mt)	cl.Length (cm)	Weight (gr)	Diameter (mm)	Sections
CAEM50A	2,00	100	47	19,00	2
CAEM50B	2,50	100	60	15,50	3
CAEM50C	3,00	100	79	18,00	4
CAEM50D	3,50	110	104	19,70	4
CAEM50E	4,00	110	121	20,70	5
CAEM50F	4,50	117	136	22,00	5
CAEM50G	5,00	120	162	22,60	5

# ALBORELLA BLEAK

## RECORD

MEDIUM - ACTION 1

Serie di canne nate e concepite per la pesca in velocità di grandi alborelle e gardon.

*Rod series conceived for big bleaks and big gardons fishes speed fishing.*

CODE	Length (mt)	cl.Length (cm)	Weight (gr)	Diameter (mm)	Sections
CARE01	2,00	111	45	12,00	3
CARE01A	2,50	111	64	15,80	3
CARE01B	3,00	111	88	17,60	4
CARE01C	3,50	111	106	18,40	4
CARE01D	4,00	111	124	19,30	5
CARE01E	4,50	111	148	20,30	5
CARE01F	5,00	111	205	23,30	6



# SPECIAL TROUT

CANNE - RODS

## BLACK TROUT

XXT

MEDIUM - ACTION 1

Realizzate per la pesca della trota nei torrenti. Particolarmente indicata per la competizione.

*Especially developed for river trout fishing. Ideal for the competition.*

W/GUIDES

CODE	Length (mt)	cl.Length (cm)	Weight (gr)	Diameter R/S (mm)	Sections
CABL03	10,20	176	497	37,00	8

NO GUIDES

CODE	Length (mt)	cl.Length (cm)	Weight (gr)	Diameter R/S (mm)	Sections
CABL03A	10,20	160	450	37,00	8

**SOLD OUT**

Series: OS

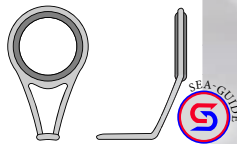

LEG: Short  
STONE: Sic  
FRAME COLOR: Black

CAXIN  
REEL SEAT



## KANSAS TROUT

X5

STRONG - ACTION 2

Realizzate per la pesca al tocco della trota nei torrenti medio piccoli.

*Expressly made for trout fishing in medium and small creeks.*

CODE	Length (mt)	cl.Length (cm)	Weight (gr)	Diameter R/S (mm)	Sections
CAKA60A	6,00	14,90	355	25,00	6
CAKA60B	7,00	15,20	440	27,00	7
CAKA60C	8,00	15,60	620	30,10	8

**KANSAS TROUT 6,00mt:**

1°block (5,00mt) - 2°block (4,00mt)

**KANSAS TROUT 7,00mt:**

1°block (6,00mt) - 2°block (5,00mt) - 3°block (4,00mt)

**KANSAS TROUT 8,00mt:**

1°block (7,00mt) - 2°block (6,00mt) - 3°block (5,00mt)

4°block (4,00mt)

Series: OS

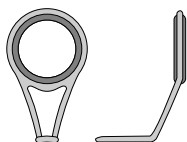

LEG: Short  
STONE: Simil Sic  
FRAME COLOR: Black

**SOLD OUT**





**Series: XM**

LEG: Micro Guides  
STONE: Sic  
FRAME COLOR: Black

**Series: XY**

LEG: Short  
STONE: Sic  
FRAME COLOR: Black



## TECH TROUT

XXT

### ACTION 2

Serie trota lago realizzata per coprire tutte le varianti che le competizioni richiedono. Grazie ad una affidabilità e maneggevolezza unica, sono canne nate per l'agonista più esperto, ma anche per il pescatore più esigente.

*Water trout fishing rod series have been developed to cover all the different needs of competition fishing. All rods, thanks to unique maneuverability and reliability, were developed for the more demanding competition fisherman and experienced anglers.*

CODE	Action	Length (mt)	Casting W. (gr)	cl.Length (cm)	Weight (gr)	Diameter (mm)	Sections
CATE10A	N.1	3,90	0-3	126	119	17,10	4
CATE10B	N.2	4,00	1-4	126	123	17,30	4
CATE10C	N.3	4,10	3-6	130	136	17,30	4
CATE10D	N.4	4,15	4-8	130	136	18,10	4
CATE10E	N.5	4,30	6-10	132	148	18,80	5
CATE10F	N.6	4,40	8-15	137	154	19,20	5
CATE10G	N.7	4,60	10-20	137	177	20,50	5
CATE10H	N.8	4,65	20-30	135	179	20,60	5
CATE10I	N.9	4,80	30-40	135	247	22,50	5



\* Available without rings and reel seat.



Series: OS

LEG: Short  
STONE: Sic  
FRAME COLOR: Black

Series: MK

LEG: Micro Guides  
STONE: Sic  
FRAME COLOR: Black



## AMBRA TROUT



### ACTION 3

Proposta in una gamma che va dall'azione 1 (1-4 gr) all'azione 6 (15-30 gr), Ambra Trout asseconda ogni tipo di esigenza legata alla gara, o alla pesca amatoriale. Componentistica pregevole e assemblaggio perfetto.

*Ambra Trout has been developed taking care to the wrapping on the sections. Ambra Trout meet any need coming both from competition and amateur fishing. This superb rod is completed by a quality components and a perfect assembly.*

CODE	Action	Length (mt)	Casting W. (gr)	cl.Length (cm)	Weight (gr)	Diameter (mm)	Sections
CAAM60A	N.1	4,00	1-4	110	145	15,50	6
CAAM60B	N.2	4,00	2-6	120	147	15,50	6
CAAM60C	N.3	4,10	4-10	130	160	15,80	6
CAAM60D	N.4	4,30	8-15	130	187	17,70	6
CAAM60E	N.5	4,40	10-20	140	218	18,90	6
CAAM60F	N.6	4,50	15-30	140	225	18,90	6

## SPRINT TROUT

MEDIUM - ACTION 3

Serie di canne trota lago vendute senza componentistica, ideali per il pescatore esigente che preferisce avere una sua totale personalizzazione in pesca.

*A still water trout fishing series sold without components. It's ideal for the more expert anglers who wants to customise it by his choice.*

CODE	Action	Length (m)	Casting W. (gr)	cl.Length (cm)	Weight (gr)	Diameter (mm)	Sections
CASP70A	N.1	4,00	1-4	100	86	13	7
CASP70B	N.2	4,00	2-6	113	90	13,10	7
CASP70C	N.3	4,10	4-10	126	99	13,20	7
CASP70D	N.4	4,30	8-15	126	122	15,30	7
CASP70E	N.5	4,40	10-20	126	143	16,30	7
CASP70F	N.6	4,50	15-30	130	148	16,40	7



CUSTOMIZABLE RODS

# TELE MATCH

## SPIDER MATCH XT

MEDIUM STRONG - ACTION 2

Top di gamma estremamente leggera e bilanciata per pronte ferrate, è una canna di un'affidabilità eccezionale anche per la pesca in mare.

*Top of range tele match rod, light and fast responsive on the strike, is perfect also for heavy duty saltwater fishing.*

CODE	Length (mt)	Casting W. (gr)	cl.Length (cm)	Weight (gr)	Diameter (mm)	Sections
CASP55A	4,20	20-80	126	240	23,50	5
<b>SOLD OUT</b>	4,50	20-80	136	270	23,30	5

Series: YGS



LEG: Medium  
STONE: Simil Sic  
FRAME COLOR: Gun Smoke



**SOLD OUT**

## ACTIVE XT

SUPER STRONG - ACTION 3

Canna all-round estremamente maneggevole ideale per prede anche di grossa taglia.

*All-round rod, strong and maneuverable, suited for heavy duty fishing.*

CODE	Length (mt)	Casting W. (gr)	Weight (gr)	Diameter (mm)	Sections
CAAC10A	4,00	30-120	360	22,70	4
CAAC10B	4,20	30-120	360	22,70	4
CAAC10C	4,50	30-120	364	22,80	4

**SOLD OUT**

X-Carbon



Series: YGS



LEG: Medium  
STONE: Simil Sic  
FRAME COLOR: Black



## ALIAINT MATCH XS

STRONG - ACTION 3

Canna all-round indicata per la pesca in mare e in torrente.

*All-round rod, perfect for river or sea fishing.*

CODE	Length (mt)	Casting W. (gr)	cl.Length (cm)	Weight (gr)	Diameter (mm)	Sections
CAAL90A	4,00	80	132	285	21,60	5
CAAL90B	4,20	80	134	353	25,60	6

Series: OS

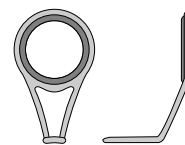

LEG: Short  
STONE: Simil Sic  
FRAME COLOR: Black



Series: XM



LEG: Micro Guides  
STONE: Sic  
FRAME COLOR: Gun Smoke



Series: XY



LEG: Short  
STONE: Sic  
FRAME COLOR: Gun smoke



**CAXIN**  
REEL SEAT



## LAREO

x5

MEDIUM - ACTION 2

Canna dal minimo ingombro è particolarmente indicata per la pesca in piccoli torrente o nei porti.

*Ultra compact rod, perfect for small river and harbor fishing.*

CODE	Length (mt)	Casting W. (gr)	cl.Length (cm)	Weight (gr)	Diameter (mm)	Sections
CALA63A	3,30	5-80	68	145	18,00	7
CALA63B	3,60	5-80	78	153	18,20	7
CALA63C	3,90	5-80	80	193	20,40	8
CALA63D	4,20	5-80	88	225	20,60	8
CALA63E	4,50	5-80	90	294	23,20	9



**SOLD OUT**

## EXON

x5

STRONG - ACTION 1

Canna telescopica con il minimo ingombro è adatta a tutte le tecniche di pesca sia in acqua dolce che salata.

*Ultra compact telescopic rod suitable for all saltwater and fresh water fishing techniques.*

Series: YGS



LEG: Medium  
STONE: Stainless Steel  
FRAME COLOR: Black

CODE	Length (mt)	Casting W. (gr)	Weight (gr)	Diameter (mm)	Sections
CAEX90A	3,60	10-120	156	18,70	7
CAEX90B	3,90	10-120	280	25,60	8

**SOLD OUT**



**SOLD OUT**

## F-900 MATCH

x5

STRONG - ACTION 2

Canna versatile e robusta, è particolarmente adatta per la pesca con grosse zavorre ed a grosse prede.

*All round and strong rod, perfectly suitable for heavy loads and big specimens.*

Series: OS

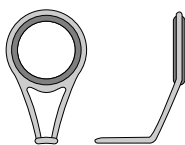

LEG: Short  
STONE: Simil Sic  
FRAME COLOR: Black

CODE	Length (mt)	Casting W. (gr)	Weight (gr)	Diameter (mm)	Sections
CAF900A1	4,00	20-120	156	23,30	4
CAF900A1	4,20	20-120	284	23,50	4

**SOLD OUT**



# TELE MATCH

CANNE - RODS

## HORNET

X5

STRONG - ACTION 2

Canna all-round robusta e maneggevole è indicata per prede anche di grossa taglia.

*All-round rod, strong and maneuverable, suited for heavy duty fishing.*

CODE	Length (m)	Casting W. (gr)	cl.Length (cm)	Weight (gr)	Diameter (mm)	Sections
CAH010A	4,00	20-80	121	270	22,90	4
CAH010B	4,30	20-80	131	300	23,00	4



X-Carbon



Series: OS

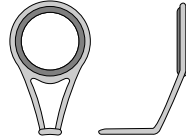

LEG: Short  
STONE: Simil Sic  
FRAME COLOR: Gun Smoke

## POLAR MATCH

X5

STRONG - ACTION 3

La versatilità e la solidità della Polar la rendono indicata per pesche pesanti in mare e in acqua dolce.

*The versatility and stiffness of the Polar make it suitable for heavy fishing in the sea and in freshwater.*

CODE	Length (m)	Casting W. (gr)	cl.Length (cm)	Weight (gr)	Diameter (mm)	Sections
CAPO82A	4,00	10-80	125	215	21,00	4
CAPO82B	4,20	10-80	131	240	21,00	4



Series: OS

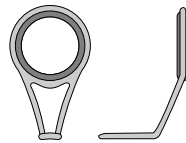

LEG: Short  
STONE: Simil Sic  
FRAME COLOR: Black

## FASHION

X5

STRONG - ACTION 3

Canna dinamica, potente, affidabile e leggera è ideale per la pesca sia in mare che in acqua dolce.

*Dynamic rod, powerful, lightweight and reliable, ideal for fishing in the sea and freshwater.*

CODE	Length (m)	Casting W. (gr)	cl.Length (cm)	Weight (gr)	Diameter (mm)	Sections
CAFA02A	4,00	10-80	125	215	21,60	4
CAFA02B	4,20	10-80	131	253	25,60	4

SOLD OUT

Series: YGS



LEG: Medium  
STONE: Simil Sic  
FRAME COLOR: Silver

SOLD OUT

# REAL SERIES

*XT*

Series: MHL

LEG: Long  
STONE: Sic  
FRAME COLOR: Gun smoke

Series: HL

LEG: Long  
STONE: Sic  
FRAME COLOR: Gun smoke



## RACE 20

*XT*

LIGHT - ACTION 3

Leggera e maneggevole è ideale per la competizione. La vetta particolarmente sensibile consente l'utilizzo fili e ami di dimensioni ridotte.

*Light and maneuverable competition rod. The very sensible tip allow the use of very light hook lengths and small hooks.*

CODE	Length (m)	Casting W. (gr)	cl.Length (cm)	Weight (gr)	Diameter (mm)	Sections
CBRE07A	4,30	20	145	205	13,20	3
CBRE07B	4,60	20	155	227	13,65	3

## NO-LIMITS

*XT*

MEDIUM STRONG - ACTION 2

Leggera e maneggevole è ideale per la pesca in competizione a lunga distanza con galleggianti pesanti.

*Light and maneuverable long distance casting competition rod, suitable for heavy floats.*

CODE	Length (m)	Casting W. (gr)	cl.Length (cm)	Weight (gr)	Diameter (mm)	Sections
CBRE04	4,50	NO LIMIT	116	240	15,40	3



# MATCH RODS - 3 SECTIONS

## PROFESSIONAL 15

XT

LIGHT - ACTION 3

Leggera e maneggevole è ideale per la competizione ad alto livello, per pesche con terminali medio sottili.

*Light and maneuverable it's perfect for competition fishing using light to medium hook lengths.*

CODE	Length (m)	Casting W. (gr)	cl.Length (cm)	Weight (gr)	Diameter (mm)	Sections
<b>SOLD OUT</b>	3,90	2-16	135	165	11,70	3
CBRE01B	4,20	2-16	145	195	12,70	3
CBRE01C	4,50	2-16	155	210	13,90	3

## PROFESSIONAL 25

XT

MEDIUM- ACTION 2/3

Leggera e maneggevole è ideale per la competizione, per pesche a medio-lunga distanza con galleggianti fino a 25gr.

*Light and maneuverable competition rod, suited for medium to long range fishing with floats up to 25gr.*

CODE	Length (m)	Casting W. (gr)	cl.Length (cm)	Weight (gr)	Diameter (mm)	Sections
CBRE02B	4,20	6-25	145	200	13,20	3
CBRE02C	4,50	6-25	155	215	14,30	3
CBRE02D	4,90	6-25	170	255	18,50	3

## PROFESSIONAL 30

XT

MEDIUM - ACTION 2

Leggera e maneggevole è ideale per la competizione, per pesche a medio-lunga distanza con galleggianti fino a 30gr.

*Light and maneuverable competition rod, suited for medium to long range fishing with floats up to 30gr.*

CODE	Length (m)	Casting W. (gr)	Weight (gr)	Diameter (mm)	Sections
<b>SOLD OUT</b>	4,20	10-30	230	13,75	3
CBRE03B	4,50	10-30	230	14,50	3

**SOLD OUT**

**SOLD OUT**



## KIRA-M1

XT

MEDIUM - ACTION 2

Buona bilanciatura ed eccellente affidabilità. Adatta per la competizione di medio livello.

*Perfectly balanced and totally reliable. Perfect for medium level competition fishing.*

CODE	Length (mt)	Casting W. (gr)	cl.Length (cm)	Weight (gr)	Diameter (mm)	Sections
CBK101A	4,20	25	145	220	20,90	3
CBK101B	4,50	25	155	256	20,90	3



Series: MHL

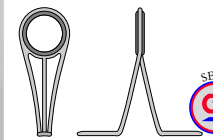

LEG: Long  
STONE: Sic  
FRAME COLOR: Frosted Gun Smoke

Series: HL



LEG: Long  
STONE: Sic  
FRAME COLOR: Frosted Gun Smoke

U.L.A.F. ULTRA LIGHT AEROSPACE FIBER



## PHANTOM NO LIMITS

X5

STRONG - ACTION 2

Questa canna dotata di ottima bilanciatura, maneggevolezza ed affidabilità, unita ad una grandissima spinta.

*Ever attentive to the canons reflecting the characteristics of a good takeapart rod, namely balance, ease of handling and reliability.*

CODE	Length (mt)	Casting W. (gr)	cl.Length (cm)	Weight (gr)	Diameter (mm)	Sections
CBPH01B	4,50	no	no	225	16,40	3

**SOLD OUT**



Series: MHL

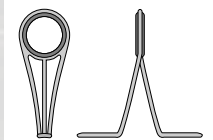

LEG: Long  
STONE: Simil Sic  
FRAME COLOR: Gun Smoke

Series: HL



LEG: Long  
STONE: Simil Sic  
FRAME COLOR: Gun Smoke

U.L.A.F. ULTRA LIGHT AEROSPACE FIBER

**SOLD OUT**

# MATCH RODS - 3 SECTIONS

## VENUS

X5

MEDIUM STRONG - ACTION 3

La VENUS è una match rod dotata di anelli big size, che favoriscono lo scorrimento del filo in particolari circostanze. Si presta quindi ad essere utilizzata per la competizione o per diletto.

*Three sections rod, equipped with big size guides which favour the line sliding, particularly during hostile circumstances. VENUS is therefore suitable for competitions or for pleasure.*

CODE	Length (mt)	Casting W. (gr)	cl.Length (cm)	Weight (gr)	Diameter (mm)	Sections
CBVE01A	3,60	5-30	125	293	13,7	3

**SOLD OUT**



Series: T



LEG: Medium  
STONE: Simil Sic  
FRAME COLOR: Gun smoke

Series: YGS



LEG: Medium  
STONE: Simil Sic  
FRAME COLOR: Gun smoke

U.L.A.F. ULTRA LIGHT AEROSPACE FIBER

## GRIFON MATCH

STRONG - ACTION 3

Canna robusta ed affidabile è particolarmente indicata per la pesca in carpodromo, per percatori meno esperti.

*Strong and reliable particularly indicated for competition fishing, for amateur fishermen.*

CODE	Length (mt)	Casting W. (gr)	cl.Length (cm)	Weight (gr)	Diameter (mm)	Sections
CBGR01A	3,60	5-30	125	293	18,40	3
CBGR01B	3,90	5-30	135	325	18,50	3

**SOLD OUT**

**SOLD OUT**



## HIRLIN MATCH

MEDIUM - ACTION 3

Canna robusta ed affidabile è particolarmente indicata per la pesca medio pesante.

*Strong and reliable particularly indicated for medium heavy fishing.*

CODE	Length (mt)	Casting W. (gr)	cl.Length (cm)	Weight (gr)	Diameter (mm)	Sections
CBHI01A	3,60	5-30	125	230	15,10	3
CBHI01B	3,90	5-30	135	240	16,50	3
CBHI01C	4,20	5-30	145	290	16,90	3

**SOLD OUT**

Series: MHL

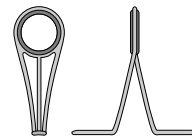

LEG: Long  
STONE: Simil Sic  
FRAME COLOR: Black

Series: HL

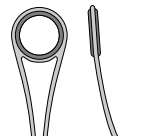

LEG: Long  
STONE: Simil Sic  
FRAME COLOR: Black



# REAL SERIES

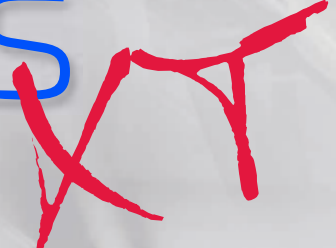

**SOLD OUT**

**SOLD OUT**



Series: MHL

LEG: Long  
STONE: Sic  
FRAME COLOR: Gun smoke

Series: HL

LEG: Long  
STONE: Sic  
FRAME COLOR: Gun smoke

## PROFESSIONAL 15



LIGHT - ACTION 3

Leggera e maneggevole è ideale per la competizione ad alto livello, per pesche con terminali medio sottili.

*Light and maneuverable it's perfect for competition fishing using light to medium hook lengths.*

CODE	Length (mt)	Weight (gr)	Diameter (mm)	Sections
CBRE05A	3,30	150	10,50	2
CBRE05B	3,60	160	11,00	2

**SOLD OUT**

## PROFESSIONAL 25



MEDIUM - ACTION 2

Leggera e maneggevole è ideale per la competizione, per pesche a medio-lunga distanza con galleggianti fino a 25gr.

*Light and maneuverable competition rod, suited for medium to long range fishing with floats up to 25gr.*

CODE	Length (mt)	Weight (gr)	Diameter (mm)	Sections
CBRE06A	3,30	160	11,15	2
CBRE06B	3,60	175	11,80	2

**SOLD OUT**



# MATCH RODS - 2 SECTIONS

## ELECTRO MATCH MEDIUM FORCE

KT

MEDIUM LIGHT - ACTION 4

Ideale per pesche meno gravose e grazie alla sua azione progressiva, ci permette di pescare anche con dei terminali sottili, senza correre il rischio di rotture sulle ferrate.

*Ideal for will suit more delicate fishing thanks to its progressive action and will allow to fish thin hook lengths avoiding striking break downs of the tippet.*

CODE	Length (mt)	Casting W. (gr)	cl.Length (cm)	Weight (gr)	Diameter (mm)	Sections
CBEL01A	3,00	Medium F.	155	154	11,75	2
CBEL01B	3,30	Medium F.	169	156	11,75	2
CBEL01C	3,60	Medium F.	185	172	12,60	2

## ELECTRO MATCH POWER FORCE

KT

MEDIUM STRONG - ACTION 4

Realizzata per impieghi un po' più gravosi quali carpodromo e tutte quelle situazioni di pesca dove si necessita di un attrezzo con maggiore potenza sia in fase di lancio, che durante il combattimento con prede importanti.

*Available will suit heavy duty fishing like big carps fisheries where a more powerful rod is required or when a more powerful casting rod is required.*

CODE	Length (mt)	Casting W. (gr)	cl.Length (cm)	Weight (gr)	Diameter (mm)	Sections
CBEL02A	3,30	Power F.	172	194	12,30	2
CBEL02B	3,60	Power F.	185	195	12,85	2



**PRO force**  
CARBON Power Double Tape

**U.L.A.F.** ULTRA LIGHT AEROSPACE FIBER

Series: MHL

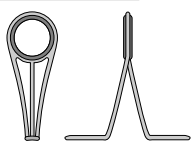

LEG: Long  
STONE: Sic  
FRAME COLOR: Gun smoke

Series: HL

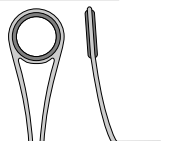

LEG: Long  
STONE: Sic  
FRAME COLOR: Gun smoke



Anelli di ultima generazione studiati appositamente per l'utilizzo di lenze sottili evitando le rotture sugli anelli. La loro forma così aerodinamica ed accattivante, è stata pensata per limitare al massimo i grovigli che il Nylon o il braided sono soggetti a creare durante la loro fuoriuscita ad altissima velocità. In questo modo sarà possibile utilizzare lenze sempre più sottili aumentando la gittata dei lanci.

Guides its a new generation guide expressly developed for thin diameter lines avoiding guides breakage. Its aerodynamic and good looking shape has been to avoid line and braid tangling produced by high line speed. Thanks to this it will be possible to use thinner and thinner lines and performing longer casts.

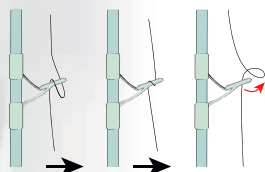
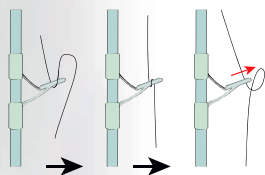

## K SERIES



## NT SERIES

## ZERO SEVEN F1

XXT

90-150gr. STRONG - ACTION 2  
100-250gr. Super STRONG - ACTION 2

La ZERO SEVEN F1-XXT è la sintesi della perfezione; una canna che se gestita con la giusta tecnica di lancio, può elargire delle distanze davvero considerevoli. Utilizzabile sia con il ground che con il pendolare.

*The Colmic ZERO SEVEN F1-XXT is the synthesis of perfection: a rod which, when managed using the right casting technique, can deliver authentically significant distances. It can be used with both ground and pendulum cast.*

CODE	Length (mt)	Casting W. (gr)	cl.Length (cm)	Weight (gr)	Diameter (mm)	Sect.
CAZE43A	4,30	100 - 250	154	450	21,50	3
CAZE43B	4,60	100 - 250	163	585	22,20	3
CAZE41A	4,60	90-150	160	428	20,15	3
SOLD OUT	4,95	90-150	177	543	21,10	3

Series: KW



LEG: Tangle Free  
STONE: Alconite  
FRAME COLOR: Silver Plated



## PRIMERA NX

XXT

60-150gr. STRONG - ACTION 2  
100-250gr. Super STRONG - ACTION 2

Canna leggera, robusta, potente e soprattutto altamente performante e perfetta per essere impiegata per eseguire ground cast estremi. La Primera NX possiede un'azione adatta a pescatori esperti che sicuramente la sapranno apprezzarla.

*Light and yet powerful rod, which allow high level performances and ideal to be used for extreme ground casting.*

CODE	Length (mt)	Casting W. (gr)	cl.Length (cm)	Weight (gr)	Diameter (mm)	Sect.
CAPR07A	4,20	60-150	151	468	20,60	3
CAPR07D	4,20	100-250	151	468	20,60	3
CAPR07E	4,60	100-250	160	568	21,90	3

Series: KW



LEG: Tangle Free  
STONE: Alconite  
FRAME COLOR: Silver Plated



# SURF CASTING

## LUNAR SURF

XT

STRONG - ACTION 2

Canna dalla potenza esplosiva, in grado di concedere le migliori performance di lancio, quando sollecitato a dovere, adatta alla pesca sulla lunga distanza, ma anche in grado di affrontare le situazioni di mare formato o la pesca dalle rocce con il vivo.

*This is an explosive power rod, top performance casting when properly handled. Long range fishing rod suitable also for high and rough seas fishing or rock fishing with live bait.*

CODE	Length (m)	Casting W. (gr)	Weight (gr)	Diameter (mm)	Sections
CALU10A	4,20	100 - 250	511	21,80	3
CALU10B	4,50	100 - 250	692	22,20	3

**SOLD OUT**

**SOLD OUT**

Series: NT



LEG: NO Tangle  
STONE: Sic  
FRAME COLOR: Chrome



PRO FORCE CARBON POWER DOUBLE TAPER

U.L.A.F. ULTRA LIGHT AEROSPACE FIBER



## PARADISE SURF

XXXT

STRONG - ACTION 2

Optimun Performance: 170gr. - Lift-UP: 5,5kg

Diametri sottilissimi, equilibratura unica, grande solidità e grandi performance. Perfetta, sia in fase di recupero che di lancio: lancio che può tranquillamente essere effettuato anche con la tecnica cosiddetta "ground cast".

*Super-slender blank diameter, unique balancing, great solidity and outstanding performance. Ideal both in casting and retrieval phases; the casting can be easily performed even using the "ground cast" technique.*

CODE	Length (m)	Casting W. (gr)	cl. Length (cm)	Weight (gr)	Diameter (mm)	Sections
CAPA80A	4,30	100 - 250	154	520	24,50	3
CAPA80B	4,60	100 - 250	163	550	24,80	3

Series: KW



LEG: Tangle Free  
STONE: Alconite  
FRAME COLOR: White Chrome



PRO FORCE CARBON POWER DOUBLE TAPER

U.L.A.F. ULTRA LIGHT AEROSPACE FIBER

# LR SERIES



## CINDY SURF

XXYT

STRONG - ACTION 2

Canna ideale per chi cerca il massimo compromesso tra prestazioni e godibilità dell'attrezzo in fase di pesca. Non eccessivamente impegnativa per quanto concerne il lancio, si carica egregiamente anche con il semplice side cast.

*The rod is the perfect compromise of performance and fun during the fishing action. Not too demanding in the casting action, it will perfectly load on a simple side cast.*

CODE	Length (mt)	Casting W. (gr)	cl.Length (cm)	Weight (gr)	Diameter (mm)	Sections
CACI50A	4,20	100 - 250	147	600	21,80	3
CACI50B	4,50	100 - 250	157	700	22,20	3

Series: LR



STONE: Alconite  
FRAME COLOR: Silver Plated



## GRAVITY SURF

XYT

STRONG - ACTION 2

Canna potente e performante, destinata ad una clientela esperta, o che comunque intende evolversi. Adatta per la tecnica di lancio "ground cast", si presta a tutti i tipi di pesca dalla spiaggia o dalla roccia. La particolare conformazione della cima consente di avvistare anche le tocche più impercettibili.

*This rod is particularly powerful and performing, more suitable for more advanced casters or for fishermen who want to enhance their casting skills, the Gravity can be also used for "ground casting". This rod is suitable for all fishing situation and can be used from the beach or from the rocks. The special feature of the tip will allow to spot even the slightest bite.*

CODE	Length (mt)	Casting W. (gr)	cl.Length (cm)	Weight (gr)	Diameter (mm)	Sections
CAGR50A	4,20	100 - 250	147	600	21,70	3
CAGR50B	4,50	100 - 250	157	700	22,50	3

Series: LR

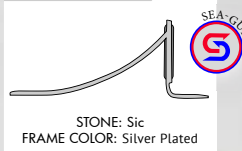

STONE: Sic  
FRAME COLOR: Silver Plated



**SOLD OUT**

**SOLD OUT**



# SURF CASTING

## IMPERIAL

XXT

STRONG - ACTION 2

Canna molto performante destinato a un pubblico esigente. L'Imperial Surf vi garantirà sempre una sensibilità in pesca di gran lunga superiore, rispetto a qualunque altra canna concepita per il lancio. Ottimo compromesso, tra prestazioni e divertimento.

*High performing rod intended for high demanding top level fishermen. The Imperial Surf will guarantee a far better sensibility to bite detection than a rod specifically developed for technical casting. The Imperial Surf will result as a perfect compromise between performances and amusement.*

CODE	Length (mt)	Casting W. (gr)	Weight (gr)	Diameter (mm)	Sections
CAIM10A	4,20	100	574	20,70	3
CAIM10B	4,50	100	574	20,90	3

SOLD OUT

SOLD OUT

Series: LR



STONE: Alconite  
FRAME COLOR: Silver Plated



## MEZCAL SURF

X5

STRONG - ACTION 2

Lift-UP: 4kg

Canna molto potente particolarmente indicata per la pesca sulla lunga distanza, utilizzando anche tecniche di lancio come il "ground cast". Questa canna può essere utilizzata anche per la pesca con il vivo o con i grossi tranci sfilettati.

*Very powerful rod, particularly indicated for long range fishing, suitable for "ground casting". This rod is perfectly suitable to rig live baits and big baitfish fillets.*

CODE	Length (mt)	Casting W. (gr)	cl.Length (cm)	Weight (gr)	Diameter (mm)	Sections
CAME88A	4,20	100 - 250	145	680	29,80	3

Series: LR

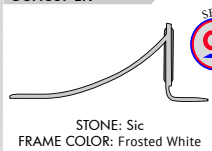

STONE: Sic  
FRAME COLOR: Frosted White



## ISLAND XKT

STRONG - ACTION 2

Optimum Performance: 150gr. - Lift-UP: 4kg

Canna realmente semplice da gestire, ma con tutte quelle caratteristiche che contraddistinguono un prodotto di fascia più elevata. Progettata su diametri di base veramente esigui, è leggera, bilanciaticissima, sensibile in pesca e si carica benissimo anche con un side cast normalmente eseguito.

*The rod is really simple to manage, bearing all the features expected from a higher end product. Rod designed on really small base diameters. It is light, extremely balanced, sensible during fishing and loads very well even with a normal side cast.*

CODE	Length (mf)	Casting W. (gr)	cl.Length (cm)	Weight (gr)	Diameter (mm)	Sections
CAISS0A	4,20	80-200	156	425	24,70	3
CAISS0B	4,50	80-200	166	440	24,80	3

Series: XQ



LEG: Short  
STONE: Sic  
FRAME COLOR: Frosted Gun Smoke

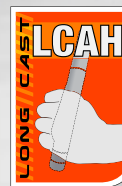

## VETERAN SURF XKT

STRONG - ACTION 2

Optimum Performance: 130gr. - Lift-UP: 3,5kg

Progettata su diametri di base sottili, è leggera, bilanciaticissima, sensibile in pesca e si carica benissimo anche con un side cast normalmente eseguito.

*Rod designed on really small base diameters. It is light, extremely balanced, sensible during fishing and loads very well even with a normal side cast.*

CODE	Length (mf)	Casting W. (gr)	cl.Length (cm)	Weight (gr)	Diameter (mm)	Sections
CAVE90A	4,20	80-200	156	480	24,70	3
CAVE90B	4,50	80-200	166	500	24,80	3

Series: XB



STONE: Sic  
FRAME COLOR: White Crome

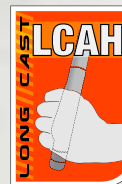

# SURF CASTING

## ANTAREX SURF

X4

STRONG - ACTION 2

Optimum Performance: 150gr. - Lift-UP: 5kg

Affidabile e robusta vi consentirà di affrontare molteplici situazioni, da quella prettamente light con mare calmo, a quella più hard con moto ondosso sostenuto.

*Reliable and robust rod is ideal with multiple situations, from a decidedly light action in calm seawaters, to a hard action in enforced strong waves.*

CODE	Length (m)	Casting W. (gr)	cl.Length (cm)	Weight (gr)	Diameter (mm)	Sections
CAAN60A	4,30	100 - 200	154	530	27,40	3
CAAN60B	4,6	100 - 200	164	585	27,40	3

Series: XB



STONE: Sic  
FRAME COLOR: White chrome

## TRILLER SURF

X5

STRONG - ACTION 2 - Lift-UP: 4kg

Canna ideale per approcciare la disciplina del surf casting. Validata per la pesca degli sparidi innescando anellidi, e per la pesca dei predatori con esche vive. Una canna potente e facile da gestire durante la fase di lancio.

*Perfect rod for beginners or as a spare rod for the more advanced fishermen without investing too much money. Perfect for sea bream and gilt heads using annelid worms, perfect also for predator fishing using live baits. A powerful rod that every angler will easily manage during the casting action.*

CODE	Length (m)	Casting W. (gr)	cl.Length (cm)	Weight (gr)	Diameter (mm)	Sections
CATR80A	4,00	100 - 250	145	670	29,8	3

Series: XB

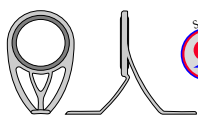

STONE: Sic  
FRAME COLOR: Frosted Gun Smoke

## AZARD SURF

X5

STRONG - ACTION 2

Affidabile e robusta vi consentirà di affrontare molteplici situazioni, da quella prettamente light con mare calmo, a quella più hard con moto ondosso sostenuto.

*Reliable and robust rod is ideal with multiple situations, from a decidedly light action in calm seawaters, to a hard action in enforced strong waves.*

CODE	Length (m)	Casting W. (gr)	cl.Length (cm)	Weight (gr)	Diameter (mm)	Sections
CAAZ01A	4,20	100 - 250	147	525	22,95	3

Series: XB



STONE: Simil Sic  
FRAME COLOR: Frosted Gun Smoke



## AMBITION

XT

### ACTION 2

Canne telescopiche dotate di cimino in carbonio pieno, affidabili, leggere e performanti. Molto semplici da gestire, si adattano perfettamente al lancio in over head e side casting, permettendo anche al pescatore meno esperto di raggiungere distanze di tutto rispetto.

*Telescopic rod series featuring a solid full carbon tip. The rods are reliable, light and performing. They are really simple to manage and perfectly suitable for both overhead and side casting. They allow even the less experienced anglers to reach long distances.*

CODE	Length (m)	Casting W. (gr)	cl.Length (cm)	Weight (gr)	Diameter (mm)	Sections
CAAM50A	4,20	120	158	370	25,30	6
CAAM50B	4,20	150	158	390	25,30	6
<b>SOLD OUT</b>	4,20	180	158	430	25,30	6
	4,50	120	158	390	25,30	6
CAAM50E	4,50	150	158	410	25,30	6

Series: MN



STONE: Simil Sic - SLIM  
FRAME COLOR: Black



## TEMPESTA

X5

### ACTION 2

Affidabili, leggere e performanti. Molto semplici da gestire, si adattano perfettamente al lancio in over head e side casting, permettendo anche al pescatore meno esperto di raggiungere distanze di tutto rispetto.

*The rods are reliable, light and performing. They are really simple to manage and perfectly suitable for both overhead and side casting. They allow even the less experienced anglers to reach long distances.*

CODE	Length (m)	Casting W. (gr)	cl.Length (cm)	Weight (gr)	Diameter (mm)	Sections
CATE02A	4,20	120	150	400	22,00	6
CATE02B	4,20	150	150	403	22,00	6
CATE02C	4,20	180	150	426	22,10	6
CATE02D	4,50	150	150	470	22,80	6
CATE02E	4,50	180	150	488	23,45	6

Series: MN



STONE: Simil Sic - SLIM  
FRAME COLOR: Black



# TELE SURF

## BLAST SURF

X5

MEDIUM - ACTION 2

Canna telescopica da surf casting molto facile da utilizzare e consente di pescare nella stragrande maggioranza delle situazioni riscontrabili dalla spiaggia, ed in altri ambiti risulta valida anche in scogliera, dove spazi ristretti necessitano di attrezzi che abbiano anche buone doti di flessibilità, oltre che di resistenza. Eccezionale rapporto qualità prezzo.

*Blast is a telescopic surf casting rod, a very handy rod that allows to easily fish from the beach in almost any situation. Thanks to its flexibility and its resistance Blast can also be effectively used for rock fishing. Outstanding quality price ratio.*

CODE	Length (mt)	Casting W. (gr)	cl. Length (cm)	Weight (gr)	Diameter (mm)	Sections
CABL89A	4,20	150	159	412	21,7	5



Series: MN



STONE: Simil Sic  
FRAME COLOR: Black

## IMPETO

X5

STRONG - ACTION 2

Canna potente, ma al tempo stesso molto "elastica". Da sottolineare, la pezzatura corta delle sezioni, che favorisce il trasporto e l'ingombro. Vetta in carbonio pieno.

*Impeto is powerful but at the same time really elastic rod. Thanks to its small sections it's really easy to carry. Carbon Solid Tip.*

CODE	Length (mt)	Casting W. (gr)	cl. Length (cm)	Weight (gr)	Diameter (mm)	Sections
CAIM02A	3,60	200	123	412	22,40	5
CAIM02B	3,90	200	133	440	22,10	5
CAIM02C	4,20	200	150	507	22,80	5



Series: MN



STONE: Simil Sic  
FRAME COLOR: Black

## AURA XF

XF

STRONG - ACTION 2

Telescopica per la pesca a surf casting. E' molto potente, affidabile ed ha un rapporto qualità prezzo molto vantaggioso.

*A telescopic rod for surf casting. The unit offers excellent power and reliability, as well as an extremely advantageous quality-price ratio.*

CODE	Length (mt)	Casting W. (gr)	cl. Length (cm)	Weight (gr)	Diameter (mm)	Sections
CAAU01A	3,30	200	123	412	21,60	4
CAAU01B	3,60	200	133	440	22,30	4
CAAU01C	3,90	250	150	490	22,30	4
CAAU01D	4,20	250	152	490	43,00	4



Series: MN



STONE: Simil Sic  
FRAME COLOR: Black

CANNE - RODS

SOLD OUT

SOLD OUT

**ARCADIA NX**

XXT

STRONG - ACTION 2

La sezione sottilissima e la grande reattività, sapranno davvero stupirvi; la sua leggerezza e la sua estrema gestibilità, faranno altrettanto.

*The very slender section and extraordinary responsiveness are sure to amaze you, as are the lightness and extreme manageability.*

CODE	Length (mt)	Casting W. (gr)	cl.Length (cm)	Weight (gr)	Diameter (mm)	Sections
CAAR70A	4,40	60-170	150	320	22,90	3+Tips
CAAR70B	4,70	60-170	160	388	22,90	3+Tips

- CARBON TIP HH
- CARBON TIP LH
- CARBON TIP MH

Series: XQ



LEG: Short  
STONE: Sic

FRAME COLOR: Frosted White

Series: XO



LEG: Micro Guides  
STONE: Sic

FRAME COLOR: Frosted White



**ETRUSKA**

XXT

Canna super leggera, potente con una azione molto sensibile, che la rende estremamente maneggevole e favorisce un movimento di lancio naturale.

*Super light and powerful rod, with very sensitive action that makes it extremely easy to handle and promotes a natural throwing motion.*

YELLOW - LIGHT - ACTION 3

CODE	Length (mt)	Casting W. (gr)	cl.Length (cm)	Weight (gr)	Diameter (mm)	Sections
CAET20A	4,60	20-100	152	334	17,90	3+Tips
CAET20B	5,00	20-100	167	395	18,80	3+Tips

- CARBON TIP LH
- CARBON TIP MH

ORANGE - MEDIUM - ACTION 2

CODE	Length (mt)	Casting W. (gr)	cl.Length (cm)	Weight (gr)	Diameter (mm)	Sections
CAET21A	4,60	40-140	160	415	22,90	3+Tips

- CARBON TIP HH
- CARBON TIP LH
- CARBON TIP MH

Series: XQ



LEG: Short  
STONE: Sic

FRAME COLOR: Frosted Gun Smoke

Series: XO



LEG: Micro Guides  
STONE: Sic

FRAME COLOR: Frosted Gun Smoke



# BEACH LEDGERING 3<sup>SEC.</sup>

CANNE - RODS



## TECNICA PRO

XXT

MEDIUM - ACTION 2

Una canna che definire "Beach ledgering" è assolutamente riduttivo. Un attrezzo troppo versatile da poter essere relegato in uno spazio circoscritto e limitato. La Tecnica Pro è stata definita dagli esperti del settore, il miglior prodotto della categoria.

*This rod cannot be defined as a "Beach ledgering", because it is very versatile. These are the reasons and we cannot talk forward, leaving the judge at your eyes experts whose will discover it. The Tecnica has been renovated exteriorly and it has been nominee by the masters as the best product of its category.*

CODE	Length (mt)	Casting W. (gr)	cl. Length (cm)	Weight (gr)	Diameter (mm)	Sections
CATE30A	4,20	30 - 130	143	390	23,20	3+Tips
CATE30B	4,50	30 - 130	154	450	23,20	3+Tips

■ CARBON TIP HH     ■ CARBON TIP LH  
■ CARBON TIP MH

Series: OS



Series: XT





**AGUGLIA NX**

XT

MEDIUM LIGHT - ACTION 3

Questo modello propone migliori prestazioni con l'affidabilità di sempre. Grazie ad un giusto mix di leggerezza rapidità e potenza è in grado di rispondere all'esigenza che nasce dovendo pescare con la tecnica della "canna in mano".

*The AGUGLIA NX is excellent and easy to use the booms with three terminals, using light leads. With perfect match of speed, lightness and power, it satisfies all the needs of fishing with "rod in the hand".*

CODE	Length (mt)	Casting W. (gr)	cl.Length (cm)	Weight (gr)	Diameter (mm)	Sections
CAAG03	5,00	20-100	153	480	18,60	3+3 tips

- █ CARBON TIP HH       CARBON TIP LH
- █ CARBON TIP MH



Series: NT

LEG: NO Tangle  
STONE: Sic  
FRAME COLOR: Black

Series: XM

LEG: Micro Guides  
STONE: Sic  
FRAME COLOR: Black

**PROMESSA NX**

XT

MEDIUM LIGHT - ACTION 3

Questa canna oltre a stupire per sensibilità e leggerezza, vi colpirà anche per la facilità di utilizzo, concedendo anche a pescatori dal tasso tecnico non elevatissimo di lanciare a distanze davvero ragguardevoli.

*Besides its amazing lightness and sensibility this rod it is also impressively manageable, thus making it easier to long cast even for less experienced fishermen.*

CODE	Length (mt)	Casting W. (gr)	cl.Length (cm)	Weight (gr)	Diameter (mm)	Sections
CAPRO5A	4,20	20 - 100	142	378	16,60	3+3 Tips
CAPRO5B	4,50	20 - 100	152	436	17,90	3+3 Tips
CAPRO5C	5,00	20 - 100	168	536	19,20	3+3 Tips

- █ CARBON TIP HH       CARBON TIP LH
- █ CARBON TIP MH



Series: NT

LEG: NO Tangle  
STONE: Sic  
FRAME COLOR: Black

Series: XM

LEG: Micro Guides  
STONE: Sic  
FRAME COLOR: Black



# TELE BEACH

SUPER SENSITIVE

Series: XY

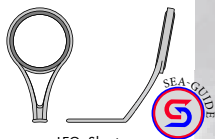

LEG: Short  
STONE: Sic  
FRAME COLOR: Frosted Gun Smoke

Series: XB

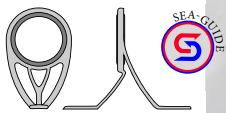

STONE: Sic  
FRAME COLOR: Frosted Gun Smoke

**CAXIN**  
REEL SEAT



## DIRECT BEACH

X4

MEDIUM LIGHT - ACTION 3

Ideale per il beach ledgering e le tutte le competizioni dove è importante avere un attrezzo che ci permetta di effettuare la pesca di ricerca con canna in mano utilizzando lenze lunghe e sottili. Leggera e bilanciata, garantisce sicurezza anche con prede di buona taglia grazie alla potenza del fusto.

*Perfect for beach ledgering and competition fishing when managing very long rigs search fishing with the rods in hands is the must. The rod is very light and balanced but can manage large specimens without problems thanks to the blank power.*

CODE	Length (mt)	Casting W. (gr)	cl.Length (cm)	Weight (gr)	Diameter (mm)	Sections
CAD130A	4,85	30-80	141	362	24,00	4+2 tips

CARBON TIP 40-80gr.



CARBON TIP 30-50gr.



## BLUE WAVE

X5

MEDIUM LIGHT - ACTION 2

Canna telescopica robusta e ben bilanciata per la pesca leggera, è consigliata per la pesca dell'orata con il granchio vivo, vista la grande sensibilità della sottile vetta in carbonio pieno.

*Blue wave it's a telescopic rod conceived for light fishing, stiff and well balanced. For his very sensitive carbon tip it his highly recommended for fishing the bream fish using alive crabs*

Series: XB

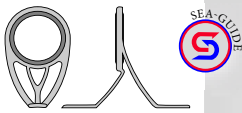

STONE: Sic  
FRAME COLOR: Black

CODE	Length (mt)	Casting W. (gr)	cl.Length (cm)	Weight (gr)	Diameter (mm)	Sections
CABL90A	4,00	20-100	149	353	19,45	4





## ADVENTURE MORMORA

x5

MEDIUM LIGHT - ACTION 2

Canna telescopica ideale per la pesca con i pasturatori. La sensibile vetta è prodotta in fibra di vetro multicolor. Eccezionale rapporto qualità prezzo!

*Telescopic rod designed for beach ledgering. Ideally suited for feeder fishing. The rod features a sensitive multicoloured fibreglass. Exceptional value for money.*

CODE	Length (mt)	Casting W. (gr)	cl.Length (cm)	Weight (gr)	Diameter (mm)	Sections
CAAD40	4,00	30-100	140	430	22,30	5



Series: T

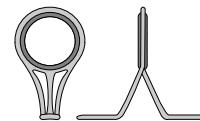

LEG: Medium  
STONE: Simil Sic  
FRAME COLOR: Black

Series: OS



LEG: Short  
STONE: Simil Sic  
FRAME COLOR: Black



## AMANTE MORMORA

X5

MEDIUM LIGHT - ACTION 2

Canna dal fusto sottile e rigido abbinato ad una vetta in fiberglass, che la rende di una sensibilità eccellente nell'avvertire le tocche dei pesci anche in situazioni avverse.

*A slender and stiff shaft, combined with a fiberglass tip, endow this rod with a super sensitivity in detecting the bites of the fish, even in adverse conditions.*

CODE	Length (mt)	Casting W. (gr)	cl.Length (cm)	Weight (gr)	Diameter (mm)	Sections
CAAM30A	4,00	100	140	428	21,90	5

Series: T

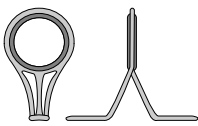

LEG: Medium  
STONE: Simil Sic  
FRAME COLOR: Black

Series: OS

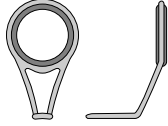

LEG: Short  
STONE: Simil Sic  
FRAME COLOR: Black

U.L.A.F. ULTRA LIGHT AEROSPACE FIBER

SST Hi-Tech SUPER SLIDING TOUCH

## MORMORA

X5

MEDIUM LIGHT - ACTION 3

Telescopica progettata per la pesca a per la pesca alla mormora. Ha un fusto rigido ed una vetta molto sensibile. Ottimo rapporto, qualità prezzo.

*A telescopic rod designed for striped bream fishing. Robust, balanced and manageable, this unit offers excellent casting performance, even for less experienced anglers. Optimal price-quality ratio.*

CODE	Length (mt)	Casting W. (gr)	cl.Length (cm)	Weight (gr)	Diameter (mm)	Sections
CAM001	3.90	80	137	440	22,50	5

Series: MN



STONE: Simil Sic  
FRAME COLOR: Black

U.L.A.F. ULTRA LIGHT AEROSPACE FIBER SST Hi-Tech SUPER SLIDING TOUCH

## FURYA



EXTRA STRONG - ACTION 1

Progettata appositamente per la pesca a bolentino di profondità. Da usare principalmente con mulinelli elettrici di notevole dimensione e peso (con capienza 800/1000 mt di braided dalle 60 alle 100 lbs). La Furia si presta egregiamente anche all'utilizzo in ambito lacustre e fluviale, laddove si vanno ad insidiare prede come il siluro.

*The rod is designed for the underneath boat fishing. It is mainly used with electric reels of a generous dimensions and weight (with capacity 800/1000 mt of braided from 60 until 100 lbs). The rod is suitable for saddled bream and groupers fishing and for all abyss's fishes. Furia can be used in lakes and in rivers as well, for big sizes fishes as the catfish.*

CODE	Length (m)	Casting W. (gr)	cl.Length (cm)	Weight (gr)	Diameter R/S (mm)	Sections
CAFUR01A	2,70	250-750	140	600	26,00	2
CAFUR01B	3,00	250-750	155	690	28,00	2
CAFUR01C	2,70	400-1300	140	660	28,00	2
CAFUR01D	3,00	400-1300	155	750	28,00	2

Series: HB

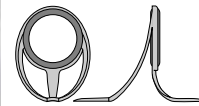

STONE: Sic  
FRAME COLOR: Black



Series: LDB



LEG: Micro Guides  
STONE: Sic  
FRAME COLOR: Black



Series: XB



STONE: Sic  
FRAME COLOR: Black



## TANUTA



STRONG - ACTION 1

Bolentino Light Medium sia per mulinello fisso che elettrico, consigliato per medie profondità (50-120mt). Una canna micidiale con il sugarello, la boga o il calamaro ,rivi, per una pesca dedicata a sua maestà il dentice o ai grossi S.Pietro.

*Boat fishing Light Medium for both fixed electric reel, recommended for medium depth (50-120m). A deadly weapon when used with live Atlantic horse mackerel, bogue or squid for fishing His Majesty the Dentex or big exemplars of John Dory.*

CODE	Length (m)	Casting W. (gr)	cl.Length (cm)	Weight (gr)	Diameter R/S (mm)	Sections
CAT8A	3,60	70-400	139	370	18,90	3



X-CARBON



# BOAT 2 SECTIONS

## DENTICE

XT

STRONG - ACTION 2

Bolentino Light consigliato per medie profondità (50-100m). Con la particolare disposizione degli anelli questa eccezionale canna può essere impiegata sia con mulinello fisso o elettrico. Nonostante la sua struttura slim, bilanciatura eccellente, la canna ha una piega armoniosa senza alcun punto di cedimento.

*Light boat fishing recommended for medium depth (50-100m). Deep boat fishing from boat and electric reels, enhanced performance despite the slim structure, excellent balancing and a harmonious flexing without any point of yield.*

CODE	Length (m)	Casting W. (gr)	cl.Length (cm)	Weight (gr)	Diameter R/S (mm)	Sections
CADE61	2,40	70-350	128	335	14,90	2
CADE61A	2,70	70-350	142	340	16,00	2
CADE61B	3,00	70-350	158	355	16,50	2
CADE61C	3,50	70-350	181	440	19,60	2



Series: LDB



LEG: Micro Guides  
STONE: Sic  
FRAME COLOR: Black

Series: XB



STONE: Sic  
FRAME COLOR: Black



## ZENNON

XT

SUPER STRONG - ACTION 1

Bolentino per mulinello elettrico, consigliato per profondità da 100 a 250m. Canna leggerissima, con una grande sensibilità di vetta realizzata, destinata al bolentino di profondità, testata su grandi occhioni e cernie anche di grossa taglia.

*For boat fishing electric reel, recommended for depths from 100 to 250m. Light rod designed for electric reel, destined use is boat fishing from boat. It has been tested on groupers, even of large dimensions.*

CODE	Length (m)	Casting W. (gr)	cl.Length (cm)	Weight (gr)	Diameter R/S (mm)	Sections
CAZE44A	2,70	100-500	142	365	18,10	2



Series: XM

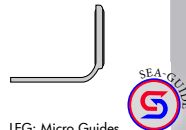

LEG: Micro Guides  
STONE: Sic  
FRAME COLOR: Black

Series: XB

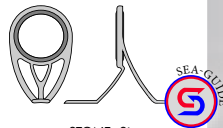

STONE: Sic  
FRAME COLOR: Black



Series: OS

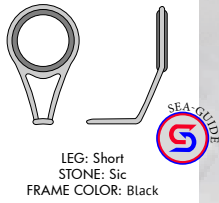

Series: XB

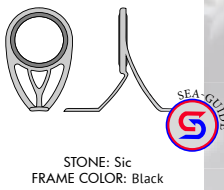

## GHEMON PRO

X5

STRONG - ACTION 2

Leggera e resistente trova le sua applicazione nella pesca a drifting e nel bolentino medio-leggero.

*Light and resistant, finding its application in the boat fishing or in the drifting fishing medim-light.*

CODE	Length (mt)	Casting W. (gr)	cl.Length (cm)	Weight (gr)	Diameter R/S (mm)	Sections
CAGH50A	2,40	300	126	204	22,70	2+2Tips
CAGH50B	2,70	300	139	219	22,70	2+2Tips
CAGH50C	3,00	300	158	240	22,70	2+2Tips

F.GLASS TIP - LH

F.GLASS TIP - HH



Series: OS

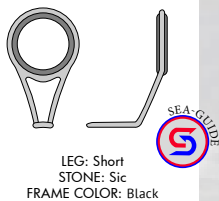

Series: XB

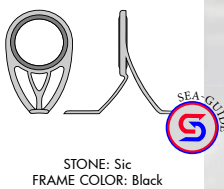

## GHEMON YOUNG

X5

STRONG - ACTION 2

Leggera e resistente trova le sua applicazione nella pesca a drifting e nel bolentino medio-leggero.

*Light and resistant, finding its application in the boat fishing or in the drifting fishing medim-light.*

CODE	Length (mt)	Casting W. (gr)	cl.Length (cm)	Weight (gr)	Diameter R/S (mm)	Sections
CAGH60A	2,40	300	126	250	23,00	2+2Tips
CAGH60B	2,70	300	139	275	23,00	2+2Tips
CAGH60C	3,00	300	158	300	23,00	2+2Tips

F.GLASS TIP - LH

F.GLASS TIP - HH



# BOAT 3 SECTIONS

## ADRIATICA

XT

MEDIUM STRONG - ACTION 3

Canna da bolettino ideale per pescare su bassi fondali e con grammature medio leggere. Molto leggera, bilanciata e affidabile.

*Boat fishing rod, ideal for fishing on not very deep sea bottom using medium /light weights. Very light and reliable.*

CODE	Length (mt)	Casting W. (gr)	cl.Length (cm)	Weight (gr)	Diameter R/S (mm)	Sections
CAAD01A	2,80	30-200	120	209	14,00	2+4Tips
CAAD01B	3,30	30-200	120	216	15,45	3+4Tips
CAAD01C	3,80	30-200	130	243	16,75	3+4Tips

F.GLASS TIP - HH

F.GLASS TIP - MH

F.GLASS TIP - LH

F.GLASS TIP - LL



Series: XT



LEG: Medium  
STONE: Sic  
FRAME COLOR: Titanium S-SC  
Treatment

Series: XY

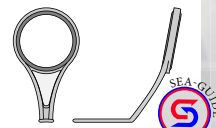

LEG: Short  
STONE: Sic  
FRAME COLOR: Titanium S-SC  
Treatment

## ARATON PRO

XT

STRONG - ACTION 2

Canna da bolettino, strutturata e progettata per tutti i fondali con grammature medio pesanti.

*Rod for boat fishing, Araton it can deal with any different type of sea boat fishing using medium / heavy weight.*

CODE	Length (mt)	Casting W. (gr)	cl.Length (cm)	Weight (gr)	Diameter R/S (mm)	Sections
CAAR02A	2,80	70-300	125	222	14,40	2+4Tips
CAAR02B	3,30	70-300	106	236	14,50	3+4Tips
CAAR02C	3,80	70-300	126	287	16,50	3+4Tips

CARBON TIP - HH

CARBON TIP - MH

CARBON TIP - LH

CARBON TIP - LL



Series: XB

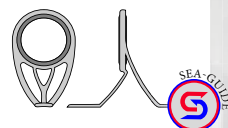

STONE: Sic  
FRAME COLOR: Titanium S-SC  
Treatment

## TIPS ADRIATICA ARATON PRO



CARBON TIPS

CODE	ACTION	COLOR
CAAR02O	HH	Red
CAAR02N	MH	White
CAAR02M	LH	Yellow
CAAR02L	LL	Orange

FIBER GLASS TIPS

CODE	ACTION	COLOR
CAAR02I	HH	Red
CAAR02H	MH	White
CAAR02G	LH	Yellow
CAAR02F	LL	Orange

Series: XM

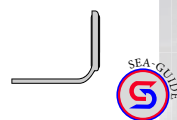

LEG: Micro Guides  
STONE: Sic  
FRAME COLOR: Titanium S-SC  
Treatment

SPECIAL SQUID

Series: XM

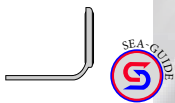

LEG: Micro Guides  
STONE: Sic  
FRAME COLOR: Black

Series: XB

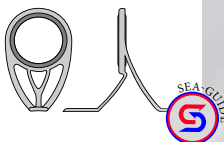

STONE: Sic  
FRAME COLOR: Black

## KITA KAREI "KK EVOLUTION"

STRONG - ACTION 3

Canna ideata per la pesca dalla barca con Misaki, Sabiki e Inchiku, sensibile con una grande riserva di potenza è adatta alla pesca di sgombri, sugarelli, con i Sabiki e calamari con i Misaki.

*Rod designed for fishing from boat with Misaki, Sabiki and Inchiku has been designed to be more reliable. Sensitive and powerful rod suitable for fishing of mackerel, jack mackerel with Sabiki and squid with Misaki.*

CODE	Length (ft)	Casting W. (gr)	cl.Length (cm)	Weight (gr)	Diameter R/S (mm)	Sections
CAK101E	6'7"	200	105	143	10,40	2
CAK101F	7'7"	200	119	161	11,80	2
CAK101G	8'7"	200	134	180	13,50	2



## RABA BORON SPINNING

ACTION 3

Canne con un'incredibile leggerezza abbinata ad un fusto potente e reattivo con azione medio progressiva, capace di animare le nostre esche in maniera eccezionale. Ideali per il vertical Fishing sia leggero che medio pesante.

*Rods incredible lightness and the powerful and reactive medium fast progressive action blank, that will perfectly work our lures. Ideal for medium-light vertical fishing on the markets today.*

CODE	Length (m)	Casting W. (gr)	ACTION	cl.Length (cm)	Weight (gr)	Diameter R/S (mm)	Sections
CARA50A	2,10	115	M	120	142	9,60	2
CARA50B	2,30	115	M	131	153	10,40	2
CARA50C	2,10	250	MH	120	154	10,60	2
CARA50D	2,30	250	MH	131	165	10,65	2

Series: XM

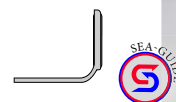

LEG: Micro Guides  
STONE: Sic  
FRAME COLOR: Titanium S-SC Treatment

Series: XB

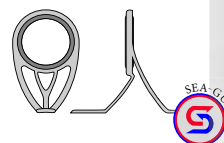

STONE: Sic  
FRAME COLOR: Titanium S-SC Treatment





# BOAT 2-3 SECTIONS

U.L.A.F. ULTRA LIGHT AEROSPACE FIBER

TREVIRA BAG

Series: LDB



LEG: Micro Guides  
STONE: Simil Sic  
FRAME COLOR: Black

Series: LR



STONE: Simil Sic  
FRAME COLOR: Black

## CALIBRA

XF

STRONG - ACTION 3

Canna ideale per ogni tipo di pesca dalla barca. Leggera, bilanciata e potentissima, sviluppa un'azione rigida ed una buona sensibilità alla vetta.

*Rod ideal for every type of boat fishing; light and balanced, it develops a stiff action with good sensitivity at the tip.*

CODE	Length (mt)	Casting W. (gr)	cl.Length (cm)	Weight (gr)	Diameter R/S (mm)	Sections
<b>SOLD OUT</b>	2,10	70-300	109	250	12,70	2
<b>SOLD OUT</b>	2,40	70-300	125	273	14,40	2
<b>SOLD OUT</b>	2,70	70-300	140	292	15,50	2
<b>CACA02D</b>	3,00	70-300	156	315	16,20	2

U.L.A.F. ULTRA LIGHT AEROSPACE FIBER

Series: T



STONE: Hardloy  
FRAME COLOR: Black



## SMASH-HH TRAVEL

XF

EXTRA STRONG - ACTION 2

Canna polivalente testata con su i grossi predatori dei mari tropicale può essere utilizzata per tutti i tipi di pesca dalla barca.

*A multipurpose rod, tested on the big predators of the tropical seas, which can be used for all types of boat fishing.*

CODE	Length (mt)	Casting W. (gr)	Weight (gr)	Diameter R/S (mm)	Sections
<b>CASMA1</b>	2,45	100	300	18,50	3
<b>CASMA2</b>	2,85	100	415	19,60	3

**SOLD OUT**

**SOLD OUT**

U.L.A.F. ULTRA LIGHT AEROSPACE FIBER

## PANTER FRAGOLINO

XF

MEDIUM STRONG - ACTION 3

Canna da bolettino medio leggero con una potenza da 20gr a 150gr, prodotta in carbonio HMC40 T, viene corredata di vetta con azione sensibile e colorata con vernice fluorescente.

*Rod for medium-light boat fishing from boat with a power range from 20 g to 150 g. Made from HMC40 T carbon, it is equipped with sensitive action tip coated with fluorescent paint.*

CODE	Length (mt)	Casting W. (gr)	cl.Length (cm)	Weight (gr)	Diameter R/S (mm)	Sections
<b>SOLD OUT</b>	1,80	20-150	94	110	8,50	2
<b>CAPA75A</b>	2,10	20-150	112	125	10,20	2
<b>CAPA75B</b>	2,40	20-150	126	160	11,20	2
<b>SOLD OUT</b>	2,70	20-150	141	180	11,90	2

Series: MN



STONE: Simil Sic  
FRAME COLOR: Black

Series: OS



LEG: Short  
STONE: Simil Sic  
FRAME COLOR: Black

Series: MK



LEG: Micro Guides  
STONE: Simil Sic  
FRAME COLOR: Black

## ALGAR XF

SUPER STRONG - ACTION 2

Canna da bolentino medio pesante, viene cordata di vetta con azione sensibile e colorata con vernice fluorescente.

Rod for medium- heavy boat fishing, it is equipped with sensitive action tip coated with fluorescent paint.

Series: MN-OB



STONE: Simil Sic  
FRAME COLOR: Black

CODE	Length (mt)	Casting W. (gr)	cl.Length (cm)	Weight (gr)	Diameter R/S (mm)	Sections
CAAL05A	2,10	100-350	113	245	17,70	2
CAAL05B	2,40	100-350	127	300	18,70	2
CAAL05C	2,70	100-350	140	345	20,00	2

**SOLD OUT**

## STERN XF XF

STRONG - ACTION 2

Canna da bolentino medio pesante. Il suo rapporto qualità prezzo è ottimo e le finiture altrettanto.

Rod for medium-heavy boat fishing from boat. The price-quality ratio is excellent, as are the finishes.

Series: MN-OB



STONE: Simil Sic  
FRAME COLOR: Black

CODE	Length (mt)	Casting W. (gr)	Weight (gr)	Diameter R/S (mm)	Sections
CAST60	2,10	200	188	18,00	2
CAST60A	2,40	200	218	19,30	2
CAST60B	2,70	200	323	19,60	2

**SOLD OUT**

## PANTER TATAKI XF

STRONG - ACTION 3

Canna nata prettamente per la tecnica del TATAKI al calamaro. Un ottimo rapporto tra qualità e prezzo.

This rod is conceived specifically for the TATAKI squid fishing technique. Superb value for money.

CODE	Length (mt)	Casting W. (gr)	cl.Length (cm)	Weight (gr)	Diameter R/S (mm)	Sections
CAPA74	1,80	30-150	94	145	12,70	2
CAPA74A	2,10	30-150	106	160	13,50	2
CAPA74B	2,40	30-150	125	220	14,60	2

Series: MN



STONE: Simil Sic  
FRAME COLOR: Black

Series: OS



LEG: Short  
STONE: Simil Sic  
FRAME COLOR: Black

Series: MK



LEG: Micro Guides  
STONE: Simil Sic  
FRAME COLOR: Black

# BOAT 2 SECTIONS

## PANTER BOLENTINO

XF

STRONG - ACTION 2

Canna per la pesca a bolentino medio leggero con azione rigida, ma con una sensibilità sulla vetta adatta alla bolentino costiero.

*Rod ideal for anyone looking for a rod for medium-light boat fishing from boat with a stiff action combined with the tip sensitivity suitable for offshore boat fishing. Unbeatable price-quality ratio.*

CODE	Length (m)	Casting W. (gr)	cl.Length (cm)	Weight (gr)	Diameter R/S (mm)	Sections
CAPA73	1,80	200	101	145	11,65	2
CAPA73A	2,10	200	111	185	14,50	2
CAPA73B	2,40	200	131	235	16,50	2
CAPA73C	2,70	200	146	260	18,10	2

## SEPIA

XF

MEDIUM STRONG - ACTION 3

Il giusto attrezzo per chi cerca una canna per la pesca a scarroccio alla Seppia con esche artificiali.

*The perfect piece of equipment for anglers looking for a rod for drifting fishing for cuttlefish using artificial lures such as shrimps and artificial fish.*

CODE	Length (m)	Casting W. (gr)	cl.Length (cm)	Weight (gr)	Diameter R/S (mm)	Sections
CASE16	1,60	120	85	125	11,80	2
CASE18	1,80	120	94	140	12,40	2
CASE20	2,00	120	104	155	12,80	2
CASE22	2,20	120	114	160	13,20	2

## ORANGE BOAT

XF

MEDIUM STRONG - ACTION 3

Canna realizzata in materiale composito, azione ideale per la pesca a i cefalopodi. Incredibile rapporto tra prezzo e qualità.

*Two-section rod made from composite material, with an ideal action for cephalopod fishing. Incredible value for money.*

CODE	Length (m)	Casting W. (gr)	cl.Length (cm)	Weight (gr)	Diameter R/S (mm)	Sections
CAOR16	1,60	100	84	120	11,00	2
CAOR18	1,80	100	93	135	12,00	2
CAOR20	2,00	100	104	145	12,30	2



Series: MK



LEG: Micro Guides  
STONE: Simil Sic  
FRAME COLOR: Black

Series: OS

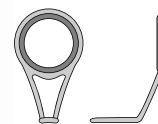

LEG: Short  
STONE: Simil Sic  
FRAME COLOR: Black

Series: MN



STONE: Simil Sic  
FRAME COLOR: Black

# SPECIAL BOLENTINO

## GALACTIC

XXX

MEDIUM STRONG - ACTION 2

Ideale per il bolettino di basso e medio fondale. Dal pagello più difficile alla più aggressiva tanuta questa canna saprà tener testa alle mangiate di qualsiasi pesce da bolettino e la sua incredibile leggerezza e resistenza esalteranno al massimo ogni vostra cattura.

*Ideal for medium dept range boat fishing. From the picky sea bream to the aggressive black sea bream this rod will handle any boat fishing bite and fish, its incredible lightness and strongness will make every capture a pleasure.*

CODE	Length (m)	Casting W. (gr)	cl.Length (cm)	Weight (gr)	Diameter R/S (mm)	Sections
CAGA100A	3,80	75-350	133	207	21,80	4+3Tips

FIBER GLASS TIP - MH

FIBER GLASS TIP - L

FIBER GLASS TIP - ML



## HARIAL

XXX

MEDIUM - ACTION 1

Pronta per tutte le esigenze di pesca dalla barca, questa canna si adatta in maniera eccellente a tutte le pesche praticabili con la tecnica del bolettino di medio e basso fondale.

*The Harial rod is the rod the any fishing boat can't miss. Perfect for any different fishing situation this all round rod will adapt to any shallow to medium range boat fishing.*

CODE	Length (m)	Casting W. (gr)	cl.Length (cm)	Weight (gr)	Diameter R/S (mm)	Sections
CAHA10A	3,70	50-200	143	295	21,80	5+3tips

FIBER GLASS TIP - MH

FIBER GLASS TIP - L

FIBER GLASS TIP - ML



## TIPS GALACTIC HARIAL

CODE	ACTION	COLOR
CAGA101A	LL	Orange
CAGA101B	L	Yellow
CAGA101C	ML	Orange
CAGA101D	MH	Red
CAGA101E	H	Yellow

SENSITIVE TIPS

ADJUSTABLE STOPPER

ADJUSTABLE STOPPER

ADJUSTABLE STOPPER

SENSITIVE TIPS

Series: KT



LEG: Micro guides  
STONE: Sic  
FRAME COLOR: Frosted White

Series: NT



LEG: NO Tangle Stone  
STONE: Sic  
FRAME COLOR: Frosted White

CAXIN REEL SEAT



# TELE-ADJUSTABLES

CANNE - RODS

Series: KT



LEG: Micro guides  
STONE: Sic  
FRAME COLOR: Frosted White

## SEA BULLET

X<sup>T</sup>

SUPER STRONG - ACTION 2

Progettata per la pesca con zavorre pesanti mantenendone però una maneggevolezza e una sensibilità eccezionale.

*Developed for heavy loads maintaining a great maneuverability and sensibility thanks to its conical taper and the two sections configuration.*

Series: NT



LEG: NO Tangle  
STONE: Sic  
FRAME COLOR: Frosted White

CODE	Length (mt)	Casting W. (gr)	cl.Length (cm)	Weight (gr)	Diameter R/S (mm)	Sections
CASEA15A	3,20-3,70	400	170	330	29,50	2+3tips



GLASS TIP LH (60-150gr - Code:CASEA16A)

GLASS TIP MH (100-200gr) - Code:CASEA16B

GLASS TIP HH (200-300gr) - Code:CASEA16C

FUJI REEL SEAT



TELESCOPIC BUTT



## SEA LION

X<sup>XT</sup>

STRONG - ACTION 1

Canna da bolentino, leggera e bilanciata ideale per profondità medie con grammature pesanti.

Rod for boat fishing, light and balanced, ideal for medium deep and heavy weight.

CODE	Length (mt)	Casting W. (gr)	cl.Length (cm)	Weight (gr)	Diameter R/S (mm)	Sections
CASEA11	3,00-4,00	50-300	141	260	19,30	4+3 Tips
<b>SOLD OUT</b>	3,50-4,50	50-300	141	300	21,80	4+3 Tips
	4,00-5,00	50-300	146	355	24,00	5+3 Tips

CARBON TIP - LL

CARBON TIP - LH

CARBONTIP - MH

Series: XM



LEG: Micro Guides  
STONE: Sic  
FRAME COLOR: Black

Series: MN



STONE: Sic  
FRAME COLOR: Black



POWER 4KG



Series: B



STONE: Sic  
FRAME COLOR: White Chrome

Series: OS



LEG: Short  
STONE: Sic  
FRAME COLOR: White Chrome

**MALIB**

MEDIUM STRONG - ACTION 1

Canna da bolentino medio – pesante, dall'ingombro ridotto ideale per essere lasciata montata nel gavone della barca.

*Bottom fishing rod - heavy, ideal for anyone looking for a rod keep assembled and ready in the locker of the boat.*

CODE	Length (mt)	Casting W. (gr)	cl.Length (cm)	Weight (gr)	Diameter R/S (mm)	Sections
<b>CAMA91A</b>	2,70	50-150	86	188	25,40	5
<b>CAMA91B</b>	3,00	50-150	96	210	25,40	5
<b>CAMA91C</b>	3,50	50-150	98	290	27,40	6



Series: MK



LEG: Micro Guides  
STONE: Simil Sic  
FRAME COLOR: Black

Series: MN



STONE: Simil Sic  
FRAME COLOR: Black

**SEA DREAM**

x5

STRONG - ACTION 1

Canna per il bolentino medio leggero.

*Rod for medium-light boat fishing from boat.*

CODE	Length (mt)	Casting W. (gr)	cl.Length (cm)	Weight (gr)	Diameter R/S (mm)	Sections
<b>CASEA14A</b>	2,50	250	104	170	16,20	3+2 Tips
<b>CASEA14B</b>	3,00	250	109	220	19,10	4+2 Tips
<b>CASEA14C</b>	3,40	250	113	285	21,20	5+2 Tips

FIBER GLASS - H



FIBER GLASS - HH



# TELE - BOAT

CANNE - RODS

## NARSIL

X5

MEDIUM STRONG - ACTION 1

Economica e robusta, questa canna si contraddistingue inoltre per una corta pezzatura delle sezioni, facendo quindi registrare un ingombro veramente minimo.

*Narsil is strong and at the same time economic, another remarkable feature of Narsil is the small size of the sections, that it makes these rods very easy to transport. Ideal for light boat fishing.*

CODE	Length (mt)	Casting W. (gr)	cl.Length (cm)	Weight (gr)	Diameter R/S (mm)	Sections
CANA47A	2,20	30-120	80	153	14,20	4
CANA47B	2,50	30-120	86	161	14,40	4
CANA47C	2,80	30-120	93	223	17,20	5



Series: T



STONE: Simil Sic  
FRAME COLOR: Black

**SOLD OUT**

## PRIUS

X4

MEDIUM STRONG - ACTION 3

Canne per il bolentino medio leggero, a pezzatura molto corta. Canna economica, ma al tempo stesso affidabile e versatile.

*Rods for medium-light boat fishing from boat. A very affordable pole, good value and at the same time reliable and versatile.*

CODE	Length (mt)	Casting W. (gr)	cl.Length (cm)	Weight (gr)	Diameter R/S (mm)	Sections
CAPR12A	2,10	50-100	100	150	15,40	4
CAPR12B	2,40	50-100	100	150	18,00	4
CAPR12C	2,70	50-100	100	150	19,80	4
CAPR12D	3,00	50-150	100	284	21,60	5

**SOLD OUT**



Series: T



STONE: Simil Sic  
FRAME COLOR: Black

## ARGENTIA

XXX

ACTION 4

Canna indicata per il Big Game fishing. Non solo pesca in drifting al tonno ma anche traina d'altura. Gli anelli roller Stuart permettono di utilizzare monofilo di qualsiasi diametro.

Rod dedicated to the "Big Game" fishing. It not only fishes Tuna in drifting, but also during throws in deep waters. The Roller Stuart guides permit to use any diameter monofilament.

CODE	Length	Casting W. (Lbs)	cl.Length (cm)	Weight (gr)	Diameter R/S (mm)	Sections
CDAR01	5'6"	50-80	127	785	13,20	1+U.B.
CDAR02	5'6"	80-120	127	1000	15,70	1+U.B.
CDAR03	6'	30-50	138	820	14,80	1+U.B.
CDAR04	6'	50-80	138	930	16,90	1+U.B.



## ONEWAY

XXX

ACTION 3

Il futuro è utilizzare il "Braided Line" in bobina. Ecco perché Colmic ha progettato una canna potente con anelli Fuji SIN-II. Oneway sarà sicuramente uno "status symbol" del Angler moderno.

The future in fishing is to use the spooled "Braided Line". This is the reason why Colmic has designed a powerful rod with Fuji SIN-II guides. "Oneway" will certainly become a "status symbol" for the modern Angler.

CODE	Length	Casting W. (Lbs)	cl.Length (cm)	Weight (gr)	Diameter R/S (mm)	Sections
CDONE01	6'	30-50	138	645	13,20	1+U.B.
CDONE02	6'	50-80	138	680	14,60	1+U.B.
CDONE03	6'6"	30-50	158	690	14,40	1+U.B.

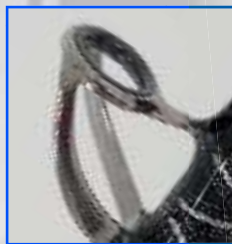

## TWIST

XXX

ACTION 3

Già da anni Colmic esegue test su canne con anelli a spirale tipo "Acid Rod". Fino a poco tempo fa non era soddisfatta di entrare sul mercato con qualcosa di usual.

For years Colmic has performed tests on rods wearing "Acid Rod" spiral guides. Until recently she was not satisfied to enter the market with something usual.

CODE	Length	Casting W. (Lbs)	cl.Length (cm)	Weight (gr)	Diameter R/S (mm)	Sections
CDTW01	6'	30-50	138	645	13,20	1+U.B.
CDTW02	6'	50-80	138	680	14,60	1+U.B.
CDTW03	6'6"	30-50	158	690	14,40	1+U.B.

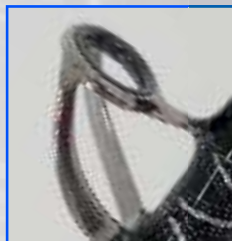

## STAND-UP CURVET BUTT

CODE: CDAR11

### COMPATIBILITY

- CDAR01 - Argentia 5'6" / 50-80Lbs
- CDAR02 - Argentia 5'6" / 80-120Lbs
- CDAR03 - Argentia 6' / 30-50Lbs
- CDAR04 - Argentia 6' / 50-80Lbs
- CDONE02 - One Way 6' / 50-80Lbs
- CDTW02 - Twist 6' / 50-80Lbs

ACID SYSTEM



## VASTAR PLATINUM

XXX

### ACTION 3

Canna sobria, leggera, slanciata, incredibilmente reattiva e potente capace di salpare le prede più grandi con meno sforzo e più rapidamente. La lunghezza di 7 piedi è indicata per la classica pesca con la sedia da combattimento dove la leva lunga compensata dalla comodità della sedia è necessaria per un sicuro pompaggio fuori dagli ostacoli, la lunghezza di 5,6 piedi è la misura ideale per la tecnica stand up in piedi, la lunghezza di 5,2 è la preferita dai nostri campioni nelle competizioni dove la leva cortissima, anche se non di facile gestione, permette con l'ausilio di particolari harnett di abbreviare moltissimo i tempi di combattimento. I calci possono essere sia dritti che curvi e le potenze, rispettate alla perfezione, sono di 30 e 50 lbs, perfette quindi per poter praticare nel migliore dei modi questa stupenda disciplina che sia in Drifting o traina Off shore.

*Rod light, slender and incredibly responsive and powerful, capable of landing the largest prey more rapidly and with the greatest of ease. The 7-foot length is recommended for classic fishing from the fighting seat, where the long leverage offset by the comfort of the seat is necessary for a secure pumping away from the obstacles. 5 foot 6 is the ideal choice for the stand-up technique, while the 5 foot 2 is the favourite with our competition champions, since the very short leverage - even though it is not so easy to manage - with the help of special harness makes it possible to greatly reduce battle times. The butts can be either straight or curved and the power, respected to perfection, ranges from 30 to 50 lbs, hence perfect for enjoying this splendid type of fishing at its best, either drifting or offshore trolling.*

CODE	Length	Casting W. (lbs)	cl.Length (cm)	Weight (gr)	Diameter R/S (mm)	Sections
<b>SOLD OUT</b>	5'6"	30	127	825	13,80	1+U.B.
CDVAPL05	7'	30	164	1015	17,80	1+U.B.
CDVAPL01	5'2"	50	117	860	13,80	1+U.B.
CDVAPL06	7'	50	165	1045	18,00	1+ U.B.

**PRO FORCE**  
CARBON POWER DOUBLE TAPER

**ULTRA LIGHT**  
AEROSPACE FIBER

STANDARD  
TIP ROLLER

30lbs

REGULAR  
ROLLER GUIDE



COMPONETS

HEAVY DUTY  
ROLLER GUIDE

HEAVY DUTY  
TIP ROLLER

50lbs

## FIGHTING CHAIR CURVED BUTT

CODE: CDVAPL07



COMPONETS

# UNIQUE IN THE WORLD!

## PRO LIGHT XXT

XXT

### ACTION 4

La loro leggerezza vi permetterà di tenere la canna in mano tutto il giorno, la loro potenza e reattività vi farà apprezzare il combattimento dall'inizio alla fine con il massimo confort e la massima tranquillità. La lunghezza 7 piedi è consigliata per chi pesca da imbarcazioni con i motori fuoribordo e per il downrigger, quella di 6'6" per le altre imbarcazioni e per la tecnica del piombo guardiano, quella di 6' per chi ha problemi con lo stivaggio.

*The lightness allows you to hold the rod all day long, while the power and response capacities will allow you to enjoy the battle from start to finish in the greatest comfort and with the utmost peace of mind. The 7-foot length is recommended for those fishing from boats with outboard motors and for downriggers, while the 6'6" is suggested for other types of boat and for trolling with sinker; finally the 6-foot rod is the perfect choice for those with storage problems.*

**SOLD OUT**

CODE	Length	Casting W.(lbs)	cl.Length (cm)	Weight (gr)	Diameter R/S (mm)	Sections
CDPRF01	6'	20	143	482	10,50	1+U.B.
CDPRF02	6'	20	143	510	11,30	1+U.B.
CDPRF04	6'6"	20	160	470	11,30	1+U.B.
CDPRF05	6'6"	20	160	519	12,10	1+U.B.
CDPRF06	7'	20	173	486	11,50	1+U.B.
CDPRF07	7'	20	173	504	12,30	1+U.B.
CDPRF08	7'	30	173	561	14,10	1+U.B.

**SOLD OUT**

Series: LR

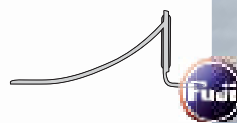

STONE: Alconite  
FRAME COLOR: Silver Plated

**PRO FORCE**  
CUT DOWN POWER ENHANCING TIPS

**U.L.A.F.** ULTRA LIGHT AEROSPACE FIBER

## CARBON UNI BUTT

# TROLLING

## PRO LIGHT XT

ACTION 4

Il gioiello di casa Colmic per quello che riguarda la traina in profondità, è ideale per gestire al meglio i combattimenti con grosse prede utilizzando mulinelli e terminali ultra leggeri.

*The glittering gem of the Colmic deep trolling sector, is ideal for managing to the best the combat with big prey using ultra-light reels and rigs.*

CODE	Length	Casting W.(lbs)	cl.Length (cm)	Weight (gr)	Diameter R/S (mm)	Sections
CDPR10	6'	30	150	575	13,10	1+U.B.
CDPR11	6'6"	12	165	550	12,60	1+U.B.
CDPR12	6'6"	20	165	565	13,00	1+U.B.
CDPR13	6'6"	30	165	590	13,50	1+U.B.
CDPR14	7'	12	180	580	13,30	1+U.B.
CDPR15	7'	20	180	600	14,00	1+U.B.
CDPR16	7'	30	180	650	15,00	1+U.B.

U.L.A.F. ULTRA LIGHT AEROSPACE FIBER

Series: LR

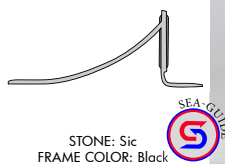

ALUMINIUM

NEOPRENE  
UNI BUTT

HEAVY DUTY  
BODY - HOODS



## PRO LIGHT WHITE SERIES XT

ACTION 4

Ideale sia per la traina costiera con esca viva sia con artificiale. Potenza e leggerezza dei materiali sono le caratteristiche vincenti.

*Its ideal use is for the trolling either as live baits as artificial. The winning material's features are power and lightness.*

CODE	Length	Casting W. (lbs)	cl.Length (cm)	Weight (gr)	Diameter R/S (mm)	Sections
CDPRW01A	7'	4-8	214	365	25	1
CDPRW01B	7'	6-12	214	390	25	1
CDPRW01C	7'	12-20	214	390	25	1
CDPRW01D	7'	20-30	214	395	25	1

U.L.A.F. ULTRA LIGHT AEROSPACE FIBER

Series: CR

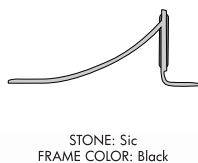

ALUMINIUM

NEOPRENE

HEAVY DUTY  
BODY - HOODS



## ADVANCED FIGHT XT

XT

**ACTION 3**

Canna con riserva di potenza eccezionale pur mantenendo inalterate le doti di sensibilità e reattività.

*In spite of its great power, Advance XXT still is a really reactive and sensible rod.*

CODE	Length (ft)	Casting W. (lbs)	cl.Length (cm)	Weight (gr)	Diameter R/S (mm)	Sections
CDAD02	6'	30	148	578	12,00	1+U.B.
CDAD03	6'6"	12	162	550	11,20	1+U.B.
CDAD04	6'6"	20	162	594	12,20	1+U.B.
CDAD05	6'6"	30	162	624	13,10	1+U.B.
CDAD06	7'	12	178	584	12,10	1+U.B.
CDAD07	7'	20	178	617	13,10	1+U.B.
CAAD08	7'	30	178	683	14,60	1+U.B.

ULTRA LIGHT AEROSPACE FIBER

**TREVIRA BAG**

Series: LR

 STONE: Sic  
 FRAME COLOR: Black

ALUMINIUM

 NEOPRENE  
 UNI BUTT

 HEAVY DUTY  
 BODY - HOODS

## LIGHT FORCE TROLLING

**MEDIUM LIGHT - ACTION 4**

Canna da trolling leggero, il diametro sottilissimo e l'incredibile leggerezza del blank, la rendono un prodotto unico. La rivoluzionaria progettazione consente di forzare il blank al massimo senza pericolo di rottura.

*Light trolling rod: the super-slender diameter and incredible lightness of the blank make it truly unique. The revolutionary design it possible to force the blank to the utmost without the slightest danger.*

ULTRA LIGHT AEROSPACE FIBER

Series: LR

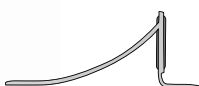
 STONE: Sic  
 FRAME COLOR: Black

CODE	Length (ft)	Casting W. (lbs)	cl.Length (cm)	Weight (gr)	Diameter R/S (mm)	Sections
CALIO2A	6'6"	4-8	164	475	10,20	1+U.B.
CALIO2B	7'	4-8	180	490	10,80	1+U.B.
CALIO2C	7'6"	4-8	195	500	10,90	1+U.B.

**UNI BUTT**

## FRENZEN PRO

**MEDIUM - ACTION 3**

Canna studiata per la traina costiere è ideale per chi si avvicina a questa meravigliosa tecnica e non vuole lasciare niente al caso.

*Inshore trolling rod, is the perfect for the fisherman approaching this wonderful technique.*

CODE	Length (ft)	Casting W. (gr)	cl.Length (cm)	Weight (gr)	Diameter R/S (mm)	Sections
CAFRO2A	1,40	100 - 400	140	206	10,70	1
CAFRO2B	1,60	100 - 400	160	260	11,00	1
CAFRO2C	1,75	100 - 400	175	289	12,20	1
CAFRO2D	1,90	100 - 400	190	350	13,00	1

# JIGGING

## LIGHT FORCE JIGGING

MEDIUM LIGHT - ACTION 4

Ideale per la pesca a vertical jigging ha una reattività in azione di pesca veramente eccezionale.

*Ideal for vertical jigging fishing, offers a truly exceptional response during fishing.*

CODE	Length (ft)	Casting W. (lbs)	cl. Length (cm)	Weight (gr)	Diameter R/S (mm)	Sections
CALI03A	5'3"	70-250	160	240	8,20	1
CALI03B	6'	70-250	180	270	9,30	1

Series: MN

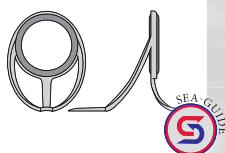

STONE: Sic  
FRAME COLOR: Black



PUT-OVER

## PREMIUM NET

XT

Questo gioiello di casa Colmic, si distingue per un bilanciamento ed una leggerezza senza pari. Il particolare diametro dei pezzi base, è compatibile inoltre con i kit carpa in quattro sezioni di tutte le nostre RBS, consentendo quindi il loro uso come prolunghe per i kit stessi. Si potrà ottenere così una robustissima e pratica mini roubaisienne (spondino), da utilizzare durante le gravose sessioni di pesca in carpo dromo.

*This latest gem from Colmic is distinguished by a peerless balance and lightness. The specific diameter of the base sections also mean that it is compatible with the 4-section carp kits of all our Roubaisienne rods, so that they can also be used as extensions for the kits. In practice, this means that you can also have a very strong and practical mini Roubaisienne to use during arduous fishing sessions in commercial carp fisheries.*

FIRST SECTION



CODE	Length (mt)	cl. Length (cm)	Weight (gr)	Diameter R/S (mm)	Sections
GXPR44	4,40	151	433	33,20	3
GXPR58	5,80	151	586	36,00	4

**SOLD OUT**

**SOLD OUT**



PUT-OVER

## SKAR K3

XT

Guadino da competizione ad innesti. Lo SKAR H3 è un binomio di leggerezza e maneggevolezza abbinata ad una affidabilità unica, caratteristiche indispensabili che deve avere un manico per guadino da gara.

*This is a competition put over landing net pole, the SKAR H3 features an incredible lightness and manageability and is totally reliable, making it a perfect competition landing net pole.*

RIVET SYSTEM



BRASS SCREW

CODE	Length (mt)	cl. Length (cm)	Weight (gr)	Diameter R/S (mm)	Sections
GXSK01A	4,20	151	433	33,20	3
GXSK01B	5,50	151	586	36,00	4



# LANDING NET HANDLES

TELESCOPIC

PUT-OVER

## CARPA X POWER <sup>XT</sup>

Questo manico per guadino, è stato appositamente studiato per affrontare le situazioni di pesca più estreme.

*This landing net handle has been specifically designed to meet the most extreme fishing situations.*

CODE	Length (mt)	cl.Length (cm)	Weight (gr)	Diameter R/S (mm)	Sections
GXCA31	3,30	121	280	25,00	3
GXCA32	4,50	121	380	25,70	4

RIVET SYSTEM

BRASS SCREW

**PRO FORCE**  
CARBON Power Double Tap

**U.L.A.F.** ULTRA LIGHT  
AEROSPACE FIBER

**SOLD OUT**

PUT-OVER

## SPECI PLUS HANDLE <sup>XT</sup>

Guadino studiato e creato per i big da carpodromo e per tutte le situazioni di pesca dove abbiamo a che fare con pesci di grandissima taglia.

*This landing net pole has been expressly developed for carpodrome fishing and for all the big specimens fishing in general.*

CODE	Length (mt)	cl.Length (cm)	Diameter (mm)	Sections
GXSP30A	3,60	121	29,80	3

**SOLD OUT**

RIVET SYSTEM

BRASS SCREW

**PRO FORCE**  
CARBON Power Double Tap

**U.L.A.F.** ULTRA LIGHT  
AEROSPACE FIBER

**SST** HI-Tech  
SUPER SLIDING TOUCH

TELESCOPIC

## ARES NET

XT

Manico veramente robusto, con una down-force notevole; questo lo rende senz'altro adatto alla competizione, ma anche alla pesca per diletto.

*Very strong landing net pole, the great down force make it suitable for both competition and leisure fishing.*

CODE	Length (mt)	cl.Length (cm)	Weight (gr)	Diameter R/S (mm)	Sections
GXR01A	4,00 - 2,80	160	350	29,25	3
GXR01B	5,50 - 4,10 - 2,80	165	530	33,00	4

ADJUSTABLE STOPPER

REINFORCED AREA 35CM



RIVET SYSTEM

BRASS SCREW



TELESCOPIC

## VALUS NET

XT

Pratico, leggero e robusto, il Valus net è adatto per la pesca al colpo e per quella in ambito marino.

*Practical, light and strong, the Valus net is perfect for coarse and for saltwater fishing.*

CODE	Length (mt)	cl.Length (cm)	Weight (gr)	Diameter R/S (mm)	Sections
GXA01B	4,25 - 3,30 - 2,30	118	335	25,5	4



ADJUSTABLE STOPPER





# LANDING NET HANDLES

PUT - OVER

## EPIC NET x5

Affidabile e robusto è adatto ai principianti della pesca ma anche per il pescatore più esperto come pratico ed economico guadino di riserva.

*Reliable and robust, it is perfect either as for the beginners either as a spare handle for the more experienced anglers.*

CODE	Length (m)	cl.Length (cm)	Weight (gr)	Diameter R/S (mm)	Sections
GXEP01A	4,00-3,00	120	490	30,00	4
GXEP01B	5,00-4,00	120	620	32,60	5

MIX CARBON

FIRST SECTION



PUT - OVER

## TENSION NET x5

Robusto ed affidabile, è dotato di un tak-a part di 30 cm.

*Very strong and reliable, it comes equipped with an 30cm take-apart.*

CODE	Length (m)	cl.Length (cm)	Weight (gr)	Diameter R/S (mm)	Sections
GXTE01A	3,30-2,20	119	420	29,50	4

MIX CARBON

FIRST SECTION



PUT - OVER

## JAVIK NET x5

Ottimo per chi si avvicina alla pesca e desidera un guadino resistente. Affidabilità e durata sono i punti di forza del Javik.

*It is ideal even for less experienced anglers. Reliability and long duration are its major features.*

CODE	Length (m)	cl.Length (cm)	Weight (gr)	Diameter R/S (mm)	Sections
GXJA01A	3,00	114	365	29,80	3
GXJA01B	4,00	114	340	34,50	4

MIX CARBON

FIRST SECTION



MANICI DI GUADINO - LANDING NET HANDLES





TELESCOPIC

## SECTOR NET

X5

Guadino in Mix – Carbon, affidabile, robusto viene usato, sia dagli agonisti, che da chi pesca per diletto, in quanto risulta maneggevole e leggero.

*Very strong telescopic landing net in Carbon-Mix. It is suitable both as a reserve net for competition anglers and for anyone looking for a good, light and manageable landing net.*

### MIX CARBON

FIRST SECTION



CODE	Length (mt)	cl.Length (cm)	Weight (gr)	Diameter R/S (mm)	Sections
GXSE01A	3,00	115	320	26,00	3
<b>SOLD OUT</b>	4,00	115	475	28,40	4
	5,00	115	630	31,30	5

TELESCOPIC

## ERON PRO

X5

Maneggevole, rigido e molto robusto, ideale per le più svariate tecniche di pesca.

*It is handy and stiff, the ERON PRO is suitable for all fishing techniques.*

### MIX CARBON

FIRST SECTION



CODE	Length (mt)	cl.Length (cm)	Weight (gr)	Diameter R/S (mm)	Sections
GXER50A	2,00	114	190	24,50	2
GXER50B	3,00	114	285	27,80	3
GXER50C	4,00	114	440	31,50	4

**SOLD OUT**

TELESCOPIC

## BYTTE XF

XF

Maneggevole, rigido e molto robusto, ideale per le più svariate tecniche di pesca.

*It is handy and stiff, the Byte is suitable for all fishing techniques.*

### MIX CARBON

FIRST SECTION



CODE	Length (mt)	cl.Length (cm)	Diameter R/S (mm)	Sections
GXBY01A	2,00	114	25,00	2

**SOLD OUT**

## FIBERGLASS TIPS

WITH GUIDES	WITHOUT GUIDES				
CODE	CODE	LENGTH MM	BOTTOM Ø MM	ACTION	COLOR
SOLD OUT	VE015	600	4,50	Soft	Yellow
SOLD OUT	VE016	600	4,50	Medium - Strong	Orange
SOLD OUT	VE017	650	4,50	Medium	Orange
SOLD OUT	VE018	600	5,00	Soft	Yellow
SOLD OUT	VE019	600	5,00	Medium	Orange
SOLD OUT	SOLD OUT	600	5,00	Strong	Red
SOLD OUT	VE021	650	5,00	Soft	Yellow
SOLD OUT	SOLD OUT	650	5,00	Medium - Soft	Green
SOLD OUT	SOLD OUT	650	5,00	Medium - Strong	Orange
SOLD OUT	SOLD OUT	650	5,00	Strong	Red
SOLD OUT	SOLD OUT	700	5,00	Soft	Yellow
VE012	SOLD OUT	700	5,00	Medium	Orange
SOLD OUT	SOLD OUT	750	5,00	Soft	Yellow
VE014	SOLD OUT	750	5,00	Medium	Orange



## CARBON TIPS

CODE	LENGTH MM	TOP Ø MM	BOTTOM Ø MM
SOLD OUT	500	0,80	2,00
SOLD OUT	550	0,70	2,30
SOLD OUT	550	0,80	2,30
SOLD OUT	600	0,80	2,30
SOLD OUT	600	0,90	2,50
SOLD OUT	600	0,90	2,70
SOLD OUT	650	0,90	2,70



# Nuclear

## HOOKS MADE IN JAPAN

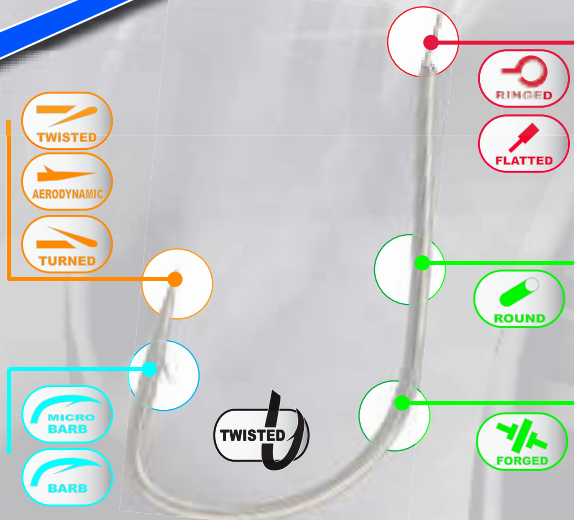

Ami NUCLEAR in acciaio e carbonio 100 tecnologicamente perfetti. Le punte ad ago affilate chimicamente hanno la proprietà di grande robustezza e di una enorme penetrazione. Gli ardiglioni variano da micro a regular per facilitare l'innesco su esche particolarmente delicate. Tutti gli ami nuclear sono di progettazione esclusiva COLMIC.

NUCLEAR hooks in steel and carbon 100 technologically perfect for competitions and amateurs. The chemically sharpened needle points have the characteristic of being extremely strong and penetrating. This guarantees easy hooking even with the most suspicious fish. The steel diameter changes in the different series for every single hook size according to the exclusive COLMIC project.

### N957NX - B957NX

NICKEL - BRONZE



20 pcs per Bag - 10pcs per Pack

**MATCH LINE**



Amo ideale per pesci difficili per i quali è necessario un innesco che risulti sempre perfetto. Ottimo in acque dolci.

*The ideal hook for "difficult" fish for which the bait must always be perfectly rigged to ensure it remains strong and vital. Excellent in inland waters.*

BRONZE		NICKEL	
Code	Size	Code	Size
AMY12	12	AMZ12	12
AMY14	14	AMZ14	14
AMY16	16	AMZ16	16
AMY18	18	AMZ18	18
AMY20	20	AMZ20	20

### N500 - NX

NICKEL



20 pcs per Bag - 10pcs per Pack

**CARP LINE**

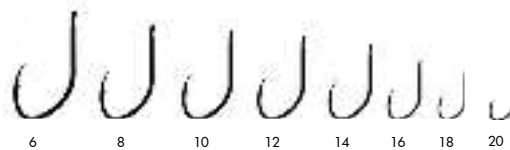

L'amo ideale per carpe e grossi pesci. Usato con successo dai migliori agonisti del nostro team.

*The special bend ensures a perfect hold on the hooked fish and easy landing. Used successfully by our team.*

Code	Size
AMZA06	6
AMZA08	8
AMZA10	10
AMZA12	12
AMZA14	14
AMZA16	16
AMZA18	18
AMZA20	20

## N1000

NICKEL



15 pcs per Bag - 10pcs per Pack

MATCH LINE

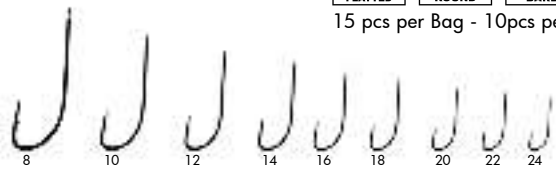

Amo dritto curva crystal, acciaio al carbonio e punta affilata chimicamente. Nelle misure più piccole, si presta egregiamente alla pesca del pesce minuto ed in quelle più grandi, può tranquillamente essere utilizzato per una pesca generica, con terminali anche generosi. La lunghezza del gambo poi, favorisce la fase di slamatura del pesce garantendo sempre una presa più salda. Molto indicato, sempre nelle misure grandi, per la pesca veloce in gare di surf casting.

*The N1000 of CURVA CRYSTAL straight hook, made in carbon steel and chemically sharpened. The smaller sizes are suitable for both tiny and bigger preys, allowing so, in between all fishing techniques, a generic fishing, also with big rigs. The long shank makes it easier to disgorge the fishes, even maintaining a strong grab. The bigger sizes are especially recommended for a quick fishing in surf casting competitions.*

Code	Size
AMLL08	8
AMLL10	10
AMLL12	12
AMLL14	14
AMLL16	16
AMLL18	18
AMLL20	20
AMLL22	22
AMLL24	24

## N600

NICKEL



20 pcs per Bag - 10pcs per Pack

MATCH LINE

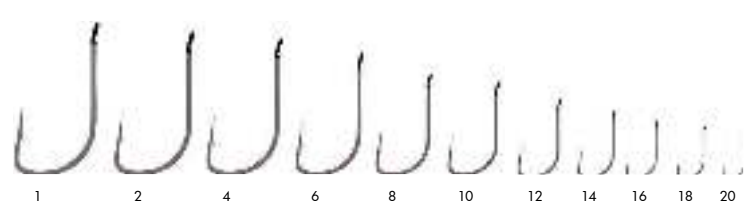

Colmic ve lo consiglia per la pesca ai ciprinidie per la pesca alla trota con l'innesco della camola o del verme di terra.

*Colmic recommends this hook; is ideal for rigging with waxworm, the medium sizes are excellent for baiting with corn.*

Code	Size
AMK01	1
AMK02	2
AMK04	4
AMK06	6
AMK08	8
AMK10	10
AMK12	12
AMK14	14
AMK16	16
AMK18	18
AMK20	20

## N957-B957

NICKEL - BRONZE



20 pcs per Bag - 10pcs per Pack

MATCH LINE

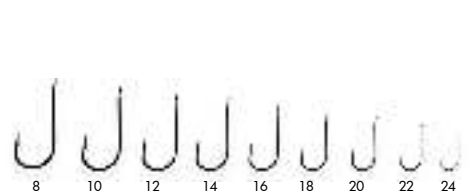

Il 957 è l'amo ideale per pesci difficili per i quali è necessario un innesco che risulti sempre perfetto. Ottimo in acque dolci.

*The 957 is the ideal hook for "difficult" fish for which the bait must always be perfectly rigged to ensure it remains strong and vital. Excellent in inland waters.*

BRONZE		NICKEL	
Code	Size	Code	Size
AMF08	8	AMM08	8
AMF10	10	AMM10	10
AMF12	12	AMM12	12
AMF14	14	AMM14	14
AMF16	16	AMM16	16
AMF18	18	AMM18	18
AMF20	20	AMM20	20
AMF22	22	AMM22	22
		AMM24	24

## B2000

BRONZE



20 pcs per Bag - 10pcs per Pack

MATCH LINE

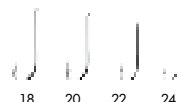

Ideale per alborella e gardon.

*Ideal for bleak e gardon.*

IDEAL FOR



Code	Size
AMA18	18
AMA20	20
AMA22	22
AMA24	24



## BS5000

BRONZE



20 pcs per Bag - 10pcs per Pack

MATCH LINE

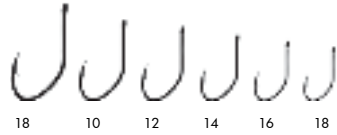

Consigliamo il BS5000 per insidiare carassi, carpe, gardons e grosse bremes.

*We recommend the BS5000 for fishing for crucians, other carp, roach, and large bream.*

Code	Size
AMP08	8
AMP10	10
AMP12	12
AMP14	14
AMP16	16
AMP18	18

## N900-B900

NICKEL - BRONZE



20 pcs per Bag - 10pcs per Pack

MATCH LINE



La robustezza di quest'amo è davvero incredibile. Indicato per tutte le specialità di pesca in acque interne e in mare con bigattino.

*This hook is incredibly durable despite the relatively fine wire section. Suitable for all inland fishing specialties and for fish of up to considerable size.*

BRONZE		NICKEL	
Code	Size	Code	Size
AMC14	14	AML12	12
AMC16	16	AML14	14
AMC18	18	AML16	16
AMC20	20	AML18	18
AMC22	22	AML20	20
		AML22	22
		AML24	24

## WB958

BRONZE



10 pcs per Bag - 10pcs per Pack

MATCH LINE

BARBLESS

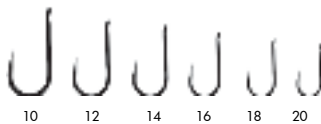

È indicato per insidiare prede diffidenti di grossa mole, innescando tutte le esche, delle quali non verrà lesa in alcun modo la vitalità.

*The WB958 is especially recommended for attracting large, shy biting fish with bluebottle larvae, horsefly larvae, or earthworms. Nor will it decrease the liveliness of these baits in any way.*

Code	Size
AMXA10	10
AMXA12	12
AMXA14	14
AMXA16	16
AMXA18	18
AMXA20	20

## WB400

BRONZE



10 pcs per Bag - 10pcs per Pack

MATCH LINE

BARBLESS

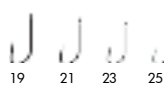

Leggerissimo e molto robusto, è adatto alla pesca di grossi pesci notoriamente molto "sospettosi".

*It is very lightweight and very strong and therefore also suitable for large fish and all other fish defined as notoriously "shy."*

Code	Size
AMRA19	19
AMRA21	21
AMRA23	23
AMRA25	25

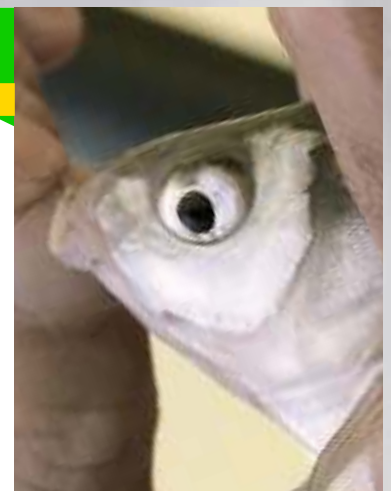

## WB610

BRONZE



10 pcs per Bag - 10pcs per Pack

**MATCH LINE**  
**BARBLESS**

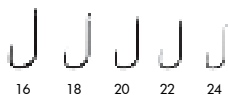

16 18 20 22 24

È indicato per pesche difficili, anche dedicate a pesci di notevole mole.  
*It's recommended for "hard-to-catch" fish, even if quite large in size.*

Code	Size
AMXB16	16
AMXB18	18
AMXB20	20
AMXB22	22
AMXB24	24

## WN501

NICKEL



10 pcs per Bag - 10pcs per Pack

**CARP LINE**  
**BARBLESS**



10 12 14 16 18 20

Molto indicato per la pesca in carpodromo, dove è importantissimo non rovinare l'apparato boccale di pesci allamati con frequenza.

*Recommended for carp fisheries, where there is a real need not to wound the mouths of fishes that are hooked repeatedly.*

Code	Size
AMHW21	10
AMHW22	12
AMHW24	14
AMHW26	16
AMHW28	18
AMHW30	20

## N500

NICKEL



20 pcs per Bag - 10pcs per Pack

**CARP LINE**

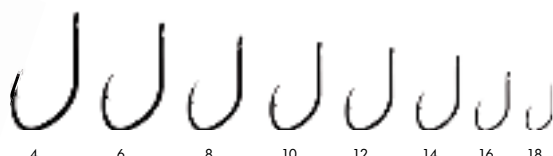

4 6 8 10 12 14 16 18

Quest'amo, è sicuramente uno dei più apprezzati dai pescatori di tutta Europa. L'amo ideale per carpe e grossi pesci. Usato con successo dai migliori agonisti del nostro team.

*This is one of the favorite hooks of anglers all over Europe. The special bend ensures a perfect hold on the hooked fish and easy landing. Used successfully by our team.*

Code	Size
AMH04	4
AMH06	6
AMH08	8
AMH10	10
AMH12	12
AMH14	14
AMH16	16
AMH18	18

## NK800-DK800

NICKEL - GOLD



20 pcs per Bag - 10pcs per Pack

**CARP LINE**



4 6 8 10 12 14 16 18

Un amo resistente a qualsiasi tipo di sollecitazione, indicato per prede di qualunque dimensione.

*A hook that will stand up to any kind of stress, suitable for any size fish.*

GOLD		NICKEL	
Code	Size	Code	Size
AMQ06	6	AMO 04	4
AMQ08	8	AMO06	6
AMQ10	10	AMO08	8
AMQ12	12	AMO10	10
AMQ14	14	AMO12	12
AMQ16	16	AMO14	14
AMQ18	18	AMO16	16
		AMO18	18

**TR99**

**BRONZE**



20 pcs per Bag - 10pcs per Pack

**TROUT LINE**

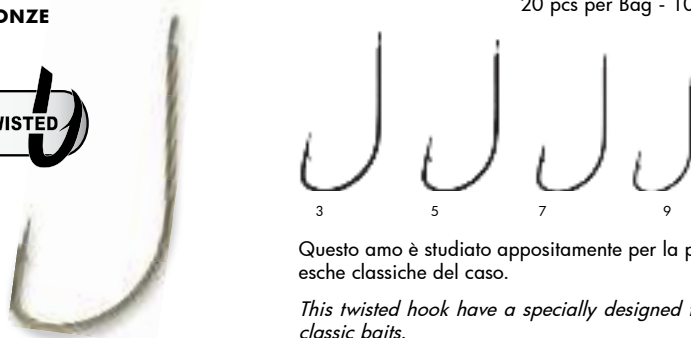

Questo amo è studiato appositamente per la pesca alla trota in torrente e lago, con tutte le esche classiche del caso.

*This twisted hook have a specially designed for stream and lake trout fishing with all the classic baits.*

Code	Size
AMU03	3
AMU05	5
AMU07	7
AMU09	9

**N510**

**NICKEL**



20 pcs per Bag - 10pcs per Pack

**TROUT LINE**

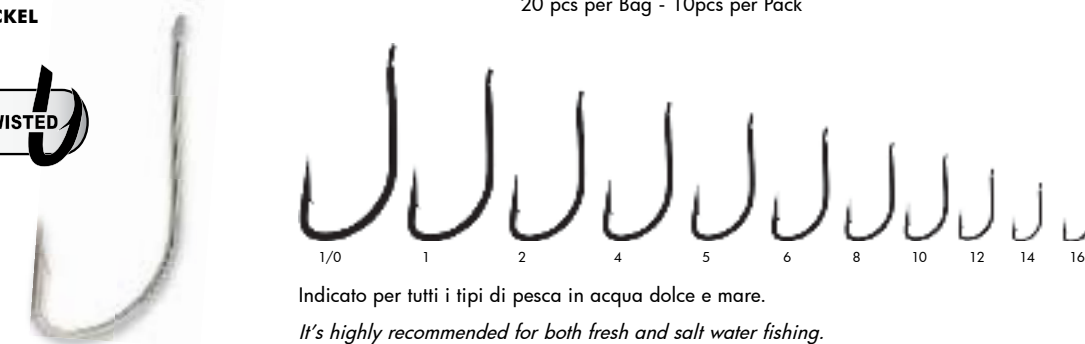

Indicato per tutti i tipi di pesca in acqua dolce e mare.

*It's highly recommended for both fresh and salt water fishing.*

Code	Size
AMJ00	1/0
AMJ01	1
AMJ02	2
AMJ04	4
AMJ05	5
AMJ06	6
AMJ08	8
AMJ10	10
AMJ12	12
AMJ14	14
AMJ16	16

# Nuclear





## SEA LINE Nuclear



### MR300

BLACK NICKEL



20 pcs per Bag - 10pcs per Pack

SEA  
LINE

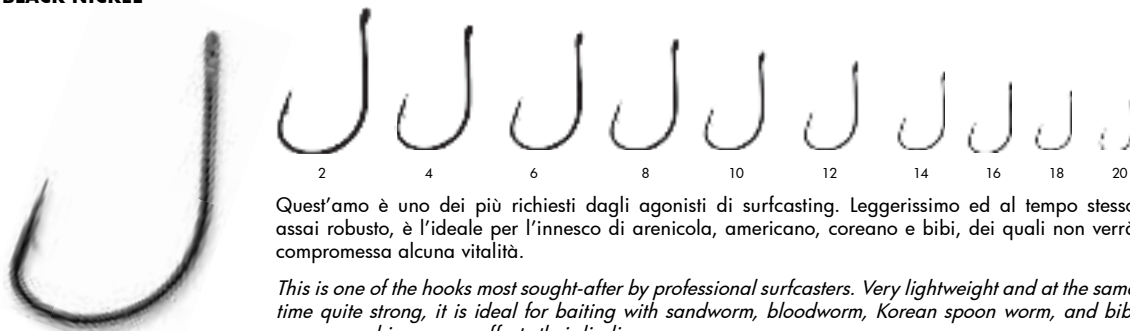

Code	Size
AM0602	2
AM0604	4
AM0606	6
AM0608	8
AM0610	10
AM0612	12
AM0614	14
AM0616	16
AM0618	18
AM0620	20

Quest'amo è uno dei più richiesti dagli agonisti di surfcasting. Leggerissimo ed al tempo stesso assai robusto, è l'ideale per l'innescò di arenicola, americano, coreano e bibi, dei quali non verrà compromessa alcuna vitalità.

*This is one of the hooks most sought-after by professional surfcasters. Very lightweight and at the same time quite strong, it is ideal for baiting with sandworm, bloodworm, Korean spoon worm, and bibi worm – and in no way affects their liveliness.*

### MR200

NICKEL



20 pcs per Bag - 10pcs per Pack

SEA  
LINE

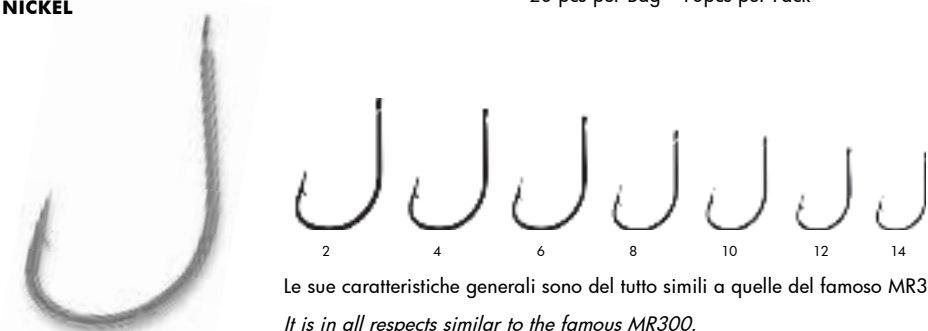

Code	Size
AM0502	2
AM0504	4
AM0506	6
AM0508	8
AM0510	10
AM0512	12
AM0514	14

Le sue caratteristiche generali sono del tutto simili a quelle del famoso MR300.

*It is in all respects similar to the famous MR300.*

### N970

NICKEL



20 pcs per Bag - 10pcs per Pack

SEA  
LINE

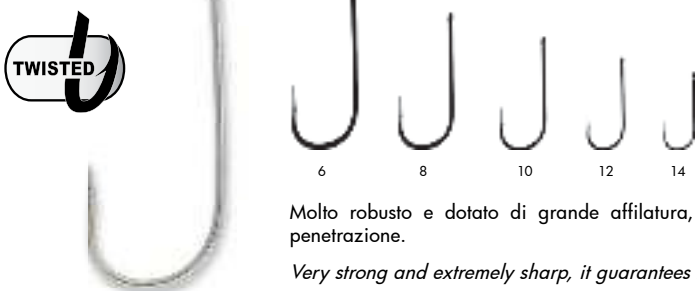

Code	Size
AMN06	6
AMN08	8
AMN10	10
AMN12	12
AMN14	14

Molto robusto e dotato di grande affilatura, garantisce affidabilità ed elevata capacità di penetrazione.

*Very strong and extremely sharp, it guarantees reliability and high penetration.*

**MR66**

**BLACK NICKEL**



10pcs per Pack

**SEA LINE**

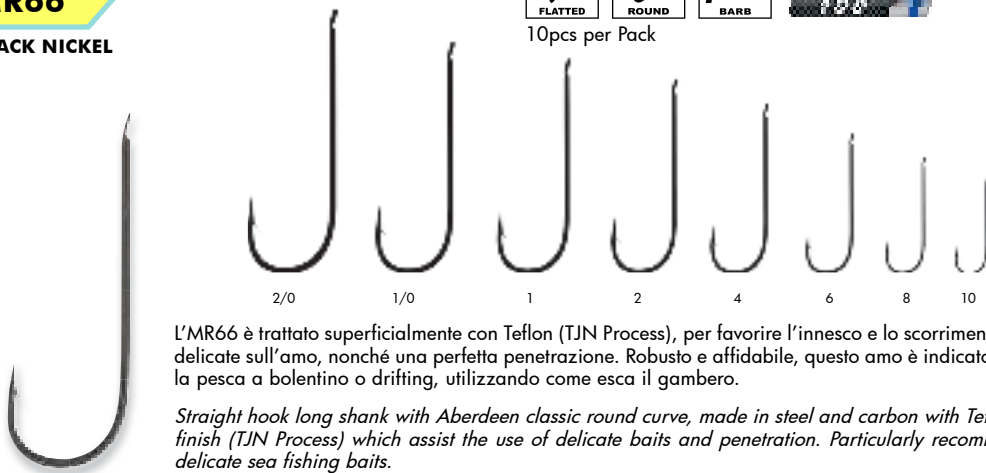

L'MR66 è trattato superficialmente con Teflon (TJN Process), per favorire l'innesco e lo scorrimento, di esche delicate sull'amo, nonché una perfetta penetrazione. Robusto e affidabile, questo amo è indicato anche per la pesca a bolentino o drifting, utilizzando come esca il gambero.

*Straight hook long shank with Aberdeen classic round curve, made in steel and carbon with Teflon surface finish (TJN Process) which assist the use of delicate baits and penetration. Particularly recommended for delicate sea fishing baits.*

Code	Size	PCS
AM0304	2/0	5
AM0305	1/0	6
AM0310	1	7
AM0320	2	8
AM0340	4	9
AM0360	6	10
AM0380	8	10
AM03100	10	10

**MR67**

**BLACK NICKEL**



10pcs per Pack

**SEA LINE**

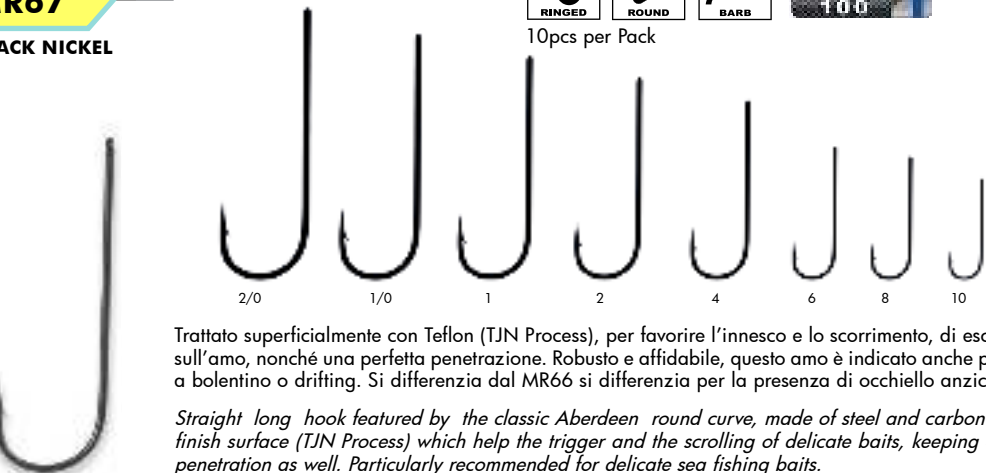

Trattato superficialmente con Teflon (TJN Process), per favorire l'innesco e lo scorrimento, di esche delicate sull'amo, nonché una perfetta penetrazione. Robusto e affidabile, questo amo è indicato anche per la pesca a bolentino o drifting. Si differenzia dal MR66 si differenzia per la presenza di occhiello anzichè paletta.

*Straight long hook featured by the classic Aberdeen round curve, made of steel and carbon with Teflon finish surface (TJN Process) which help the trigger and the scrolling of delicate baits, keeping an effective penetration as well. Particularly recommended for delicate sea fishing baits.*

Code	Size	PCS
AM03801	2/0	5
AM03802	1/0	6
AM03803	1	7
AM03804	2	8
AM03805	4	9
AM03806	6	10
AM03807	8	10
AM03808	10	10

**MR42**

**BRONZE**



10pcs per Pack

**SEA LINE**

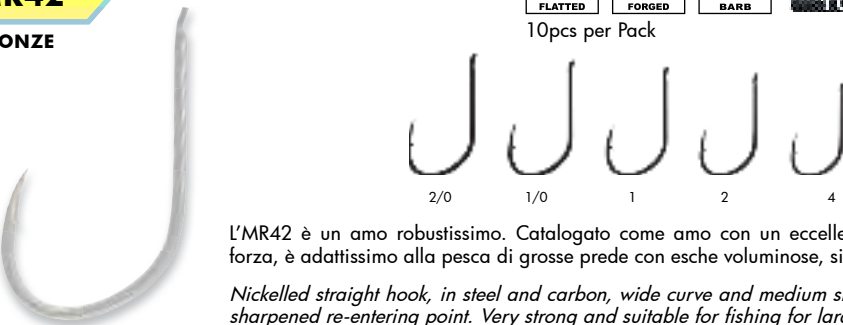

L'MR42 è un amo robustissimo. Catalogato come amo con un eccellente rapporto tra leggerezza e forza, è adattissimo alla pesca di grosse prede con esche voluminose, sia in mare che in acque interne.

*Nickelled straight hook, in steel and carbon, wide curve and medium shank. Flattened with chemically sharpened re-entering point. Very strong and suitable for fishing for large prey with voluminous baits.*

Code	Size	PCS
AM0202	2/0	8
AM0203	1/0	8
AM0210	1	8
AM0220	2	10
AM0240	4	10

**MR70**

**BLACK NICKEL**



10pcs per Pack

**SEA LINE**



Leggerissimo e fedele come pochi, viene utilizzato sia dalla barca che per la pesca a surf casting per le grandi orate e grossi sparidi.

*A highly effective and strong hook. Rockfishing testing on important fish preys such as corvina, large sparids.*

Code	Size	PCS
AM0401	1	6
AM0402	2	8
AM0404	4	10
AM0406	6	10
AM0408	8	10

## MR 700

BRONZE



10pcs per Pack

SEA LINE

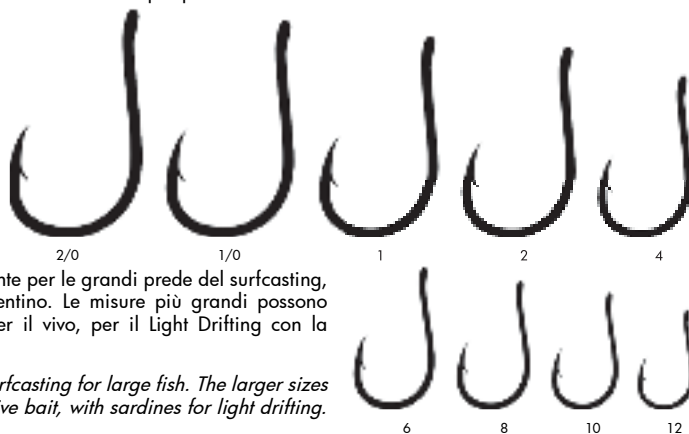

Ideato appositamente per le grandi prede del surfcasting, rock fishing e bolentino. Le misure più grandi possono essere utilizzate per il vivo, per il Light Drifting con la sarda.

*It's designed for surfcasting for large fish. The larger sizes can be used with live bait, with sardines for light drifting.*

Code	Size	PCS
AM0700	2/0	5
AM0701	1/0	5
AM0702	1	5
AM0703	2	5
AM0704	4	10
AM0706	6	10
AM0708	8	10
AM0709	10	10
AM0710	12	10

## MR 21

BLACK NICKEL



10pcs per Pack

SEA LINE

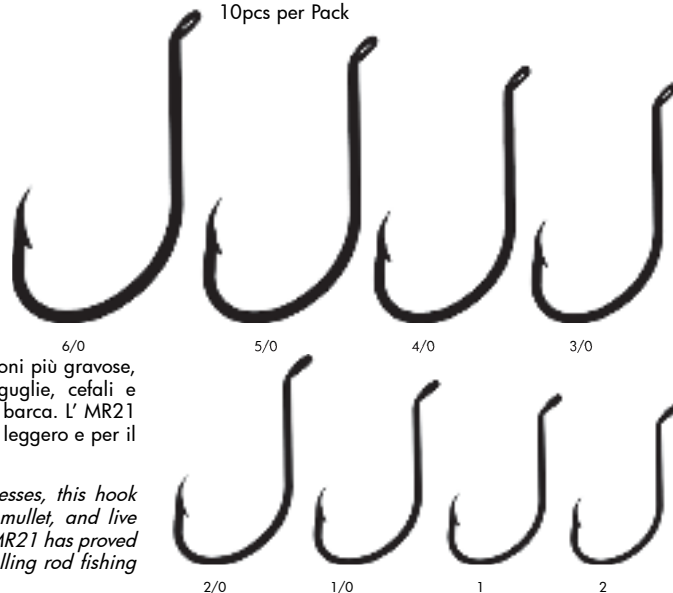

Creato appositamente per resistere alle sollecitazioni più gravose, si presta in modo particolare all'innesco di aguglie, cefali e calamari vivi, pescando in mare, da terra o dalla barca. L' MR21 si è rivelato oltremodo valido anche per il drifting leggero e per il bolentino, innescando la sarda intera o a pezzi.

*Specially created to stand up to the heaviest stresses, this hook is particularly suitable for baiting with garfish, mullet, and live calamari for sea-fishing, from shore or boat. The MR21 has proved to be just as effective for light drifting and for trolling rod fishing when rigged with whole or chunk sardines.*

Code	Size	PCS
AM0100	6/0	5
AM0101	5/0	6
AM0102	4/0	6
AM0103	3/0	6
AM0104	2/0	7
AM0105	1/0	7
AM0110	1	7
AM0120	2	8

## MR TUNA

BLACK NICKEL



10pcs per Pack

SEA LINE



Destinato a pesci di grandi dimensioni, il TUNA è particolarmente indicato per prede come appunto il tonno, il pesce spada, gli squali, ed altri pesci importanti.

*Specially destined for capturing large fish, the TUNA hook is recommended for tuna, for such targets as swordfish, shark, and other important game fish.*

Code	Size	PCS
AM0801	7/0	3
AM0802	6/0	3
AM0803	5/0	4

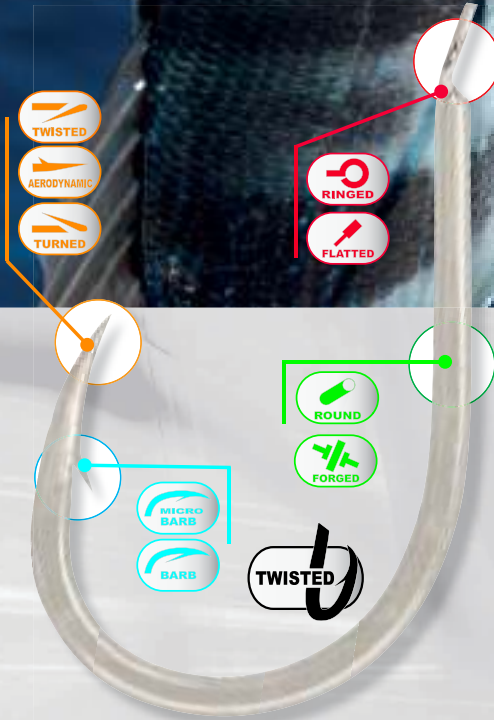
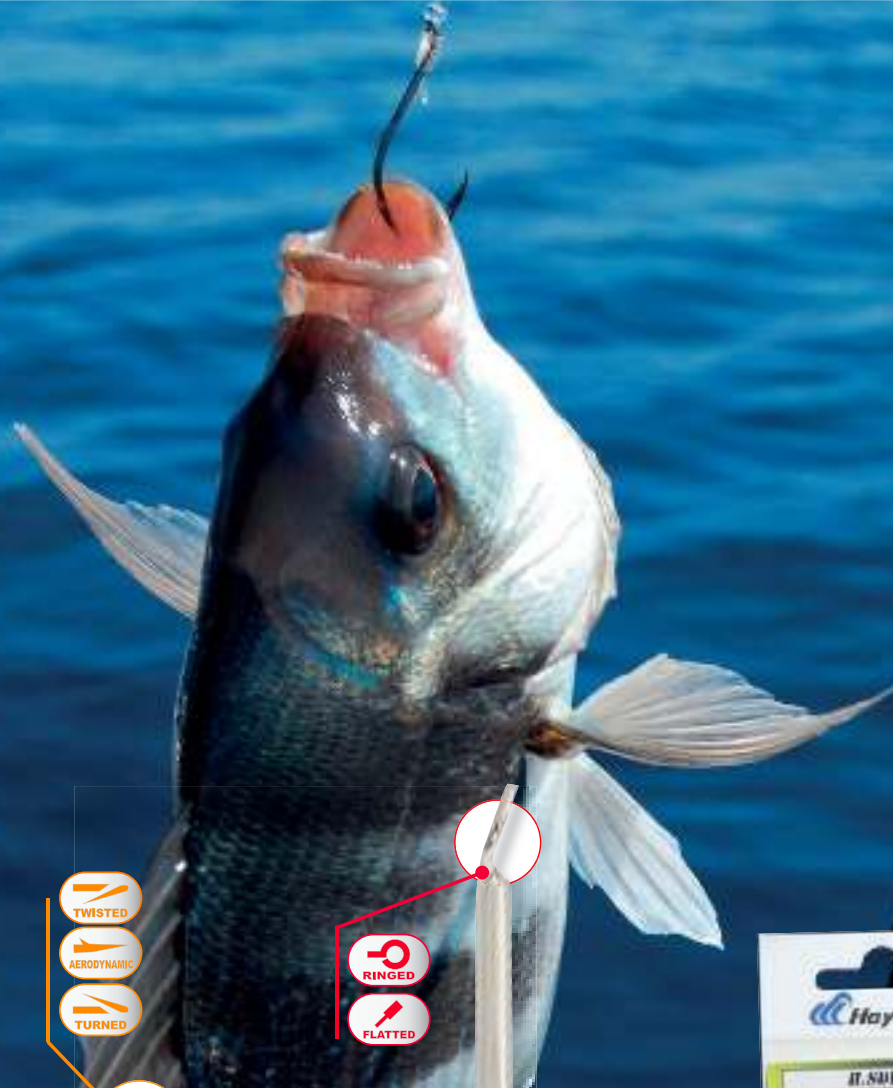
Ami giapponesi prodotti in acciaio al "CARBONIO 110" e punte ad affilatura chimica. Sono caratterizzati da diametri sottili, da un rapporto tra peso e resistenza alla trazione eccellente e da micro ardiglioni che lasciano l'esca molto vitale, pur offrendo una salda presa in fase di recupero del pesce.

*Japanese hooks made of Carbon 110 steel and chemical tool grinding tip. Characterized by a slim diameter, an excellent weight-resistance ratio and micro anchors that leave the fish vital but still offering a strong hold during fish retrieve.*

# TECHNOLOGY

**HCHK 128**
**NICKEL - BLACK NICKEL**

**ROUND**

10pcs per Bag - 15pcs per Pack



Amo leggerissimo e al tempo stesso assai robusto. Ideale per l'innesco del verde vase e bigattino.

*The HCHK 128 is a lightweight but quite strong hook. It's ideal for baiting with joker, is recommended for arousing the curiosity of any bream, crucian carp, biting chub, or roach, even specimen-size.*

**BLACK NICKEL**

CODE	Size
HAYAM128BN08	8
HAYAM128BN10	10
HAYAM128BN12	12
HAYAM128BN14	14
HAYAM128BN16	16
HAYAM128BN18	18
HAYAM128BN19	19
HAYAM128BN20	20
HAYAM128BN22	22

**NICKEL**

Code	Size
HAYAM128N08	8
HAYAM128N10	10
HAYAM128N12	12
HAYAM128N14	14
HAYAM128N16	16
HAYAM128N18	18
HAYAM128N19	19
HAYAM128N20	20
HAYAM128N22	22

**HCHN 122**
**NICKEL - BLACK NICKEL**

10pcs per Bag - 15pcs per Pack



Nonostante si tratti di un amo robusto, ideale per grosse carpe, è comunque leggero e molto affilato. Ciò consente un innesco sempre perfetto e vitale.

*Despite being a particularly robust product, ideal when targeting large fish, it remains a lightweight, very sharp hook that permits precise penetration to keep the bait pert and lively.*

**BLACK NICKEL**

CODE	Size
HAYAM122BN02	2
HAYAM122BN04	4
HAYAM122BN06	6
HAYAM122BN08	8
HAYAM122BN10	10
HAYAM122BN12	12
HAYAM122BN14	14

**NICKEL**

CODE	Size
HAYAM122N02	2
HAYAM122N04	4
HAYAM122N06	6
HAYAM122N08	8
HAYAM122N10	10
HAYAM122N12	12
HAYAM122N14	14

**DSR 132**
**NICKEL**

10pcs per Bag - 10pcs per Pack



Molto simile come risposta, alla nostra serie Nuclear MR300, questo amo ha in più una curva più rotonda e forse anche una maggior tenuta. Indicato per le tecniche di pesca a fondo dalla spiaggia, innescando vermi in genere, preserva totalmente l'integrità dell'esca. Validò anche per il feeder.

*Similar to the Nuclear MR300 series, Hayabusa DSR132 has a more rounded shape and a better grab. Recommended for surfcasting and beachledgering. This series is ideal to be used with delicate baits, but it can also be used for feeder fishing.*

**CODE**

CODE	Size
HAYAM132BM02	2
HAYAM132BM03	3
HAYAM132BM04	4
HAYAM132BM06	6
HAYAM132BM08	8

**HSDE 194**
**NICKEL**

10pcs per Bag - 15pcs per Pack

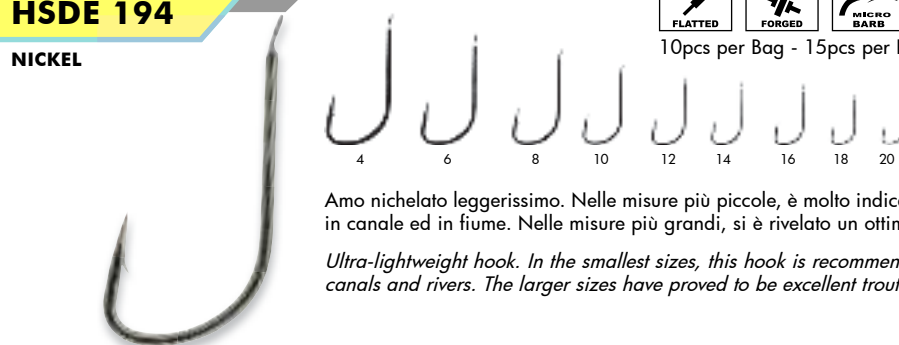

Amo nichelato leggerissimo. Nelle misure più piccole, è molto indicato per la pesca al colpo in canale ed in fiume. Nelle misure più grandi, si è rivelato un ottimo amo da trota.

*Ultra-lightweight hook. In the smallest sizes, this hook is recommended for coarse fishing in canals and rivers. The larger sizes have proved to be excellent trout hooks.*

**CODE**

CODE	Size
HAYAM194N04	4
HAYAM194N06	6
HAYAM194N08	8
HAYAM194N10	10
HAYAM194N12	12
HAYAM194N14	14
HAYAM194N16	16
HAYAM194N18	18
HAYAM194N20	20

**HYMM 220**

**NICKEL**



10pcs per Bag - 15pcs per Pack

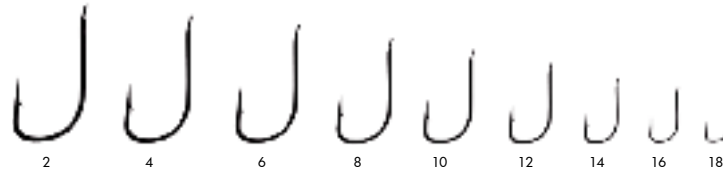

Leggero, affidabile, è un amo ideale per pesci di tutte le taglie

*It offers one of the best balances available between light weight and reliability. Ideal for small and large fishes.*

CODE	Size
HAYAM220N02	2
HAYAM220N04	4
HAYAM220N06	6
HAYAM220N08	8
HAYAM220N10	10
HAYAM220N12	12
HAYAM220N14	14
HAYAM220N16	16
HAYAM220N18	18

**HISE 145**

**NICKEL - BLACK NICKEL - GOLD**



10pcs per Bag - 15pcs per Pack



Ideale per pesche molto gravose sia in acqua dolce (grosse carpe) che in acqua salata (orate e saraghi). Un amo affidabilissimo, che è in grado di mantenere inalterata la sua affilatura anche dopo molte catture.

*Ideal for use with voluminous baits. The smaller sizes, recommended for generic baits, have been applauded by anglers at carp fisheries. A reliable hook that keeps its edge even after many catches.*

**BLACK NICKEL**

CODE	Size
HAYAM145BN02	2
HAYAM145BN04	4
HAYAM145BN06	6
HAYAM145BN08	8
HAYAM145BN10	10
HAYAM145BN12	12
HAYAM145BN14	14
HAYAM145BN16	16

**GOLD**

CODE	Size
HAYAM145G04	4
HAYAM145G06	6
HAYAM145G08	8
HAYAM145G10	10
HAYAM145G12	12

**NICKEL**

CODE	Size
HAYAM145N02	2
HAYAM145N04	4
HAYAM145N06	6
HAYAM145N08	8
HAYAM145N10	10
HAYAM145N12	12
HAYAM145N14	14
HAYAM145N16	16

**HMRS 176**

**NICKEL - BLACK NICKEL**



10pcs per Bag - 15pcs per Pack

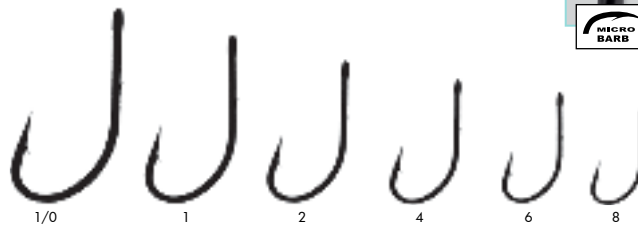

Amo robustissimo. Veramente il top dei top, per il surf casting puro e per il rock fishing.

*A very strong, straight-shanked forged hook. It's the top of the top for pure surfcasting and for rockfishing.*

**NICKEL**

CODE	Size
HAYAM176N10	1/0
HAYAM176N01	1
HAYAM176N02	2
HAYAM176N04	4
HAYAM176N06	6
HAYAM176N08	8

**BLACK NICKEL**

CODE	Size
HAYAM176BN10	1/0
HAYAM176BN01	1
HAYAM176BN02	2
HAYAM176BN04	4
HAYAM176BN06	6
HAYAM176BN08	8



**HKAJ 157**
**BLACK NICKEL - NICKEL**

10pcs per Bag - 15pcs per Pack

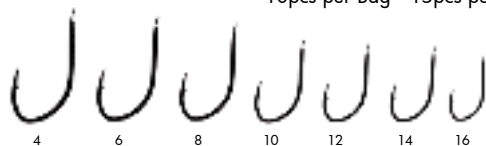

Leggerissimo, molto robusto e di sezione ultrafine. Indicato per la pesca dedicata a carassi e bremes. La sua grande capacità di penetrazione, lo rende idoneo anche per l'innescò del ver de vase.

*Lightweight and very strong the HKAJ 157 is strongly recommended for rod-and-reel fishing for crucian and bream. It penetrates easily and is thus suitable for baiting with joker, especially if your targets are large fish.*

NICKEL	
CODE	Size
HAYAM157N04	4
HAYAM157N06	6
HAYAM157N08	8
HAYAM157N10	10
HAYAM157N12	12
HAYAM157N14	14
HAYAM157N16	16

BLACK NICKEL	
CODE	Size
HAYAM157BN04	4
HAYAM157BN06	6
HAYAM157BN08	8
HAYAM157BN10	10
HAYAM157BN12	12
HAYAM157BN14	14
HAYAM157BN16	16

**HISE 147**
**BLACK NICKEL**

10pcs per Bag - 15pcs per Pack

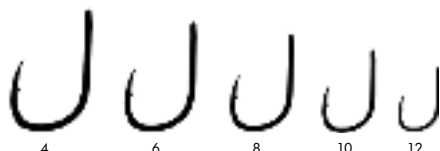

Amo robustissimo. Ideale per carpfishing e per il surf casting, quest'amo consente un innescò impeccabile ed un'affidabilità estrema.

*A very strong forged hook with eye. Ideal for carp fishing and for surf casting, this hook permits impeccable baiting and guarantees extreme reliability.*

CODE	Size
HAYAM147BN04	4
HAYAM147BN06	6
HAYAM147BN08	8
HAYAM147BN10	10
HAYAM147BN12	12

**HCHN 018**
**BLACK NICKEL**

10pcs per Bag - 15pcs per Pack

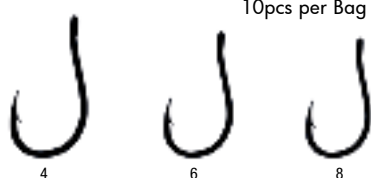

Robustissimo e quindi molto affidabile, è un amo ideale per il carp fishing. Quest'amo può essere usato con soddisfazione anche nel surf casting e nel rock fishing, con tutte le esche tipiche del caso.

*Strong and highly reliable, it is an ideal hook for carp fishing and for other large fish. This hook can also be used with good results for surf casting and rock fishing, with all the baits normally used in these specialties.*

CODE	Size
HAYAM018BN04	4
HAYAM018BN06	6
HAYAM018BN08	8

**HSNA 201**
**BLACK NICKEL**

10pcs per Bag - 15pcs per Pack

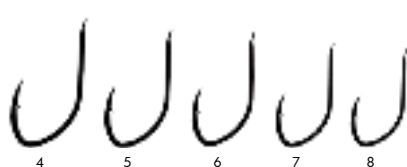

Sono caratterizzati da diametri sottili, da un rapporto tra peso e resistenza alla trazione eccellente e da micro ardiglioni che lasciano l'esca molto vitale, pur offrendo una salda presa in fase di recupero del pesce.

*The HSNA 201 has been acclaimed as one of the best hooks available for the American catfish and for all heavy fishing applications at the carp fisheries.*

CODE	Size
HAYAM201BN04	4
HAYAM201BN05	5
HAYAM201BN06	6
HAYAM201BN07	7
HAYAM201BN08	8



# Hayabusa

## SEA SELECTION



### HSOI 230

NICKEL - BLACK NICKEL



10pcs per Pack

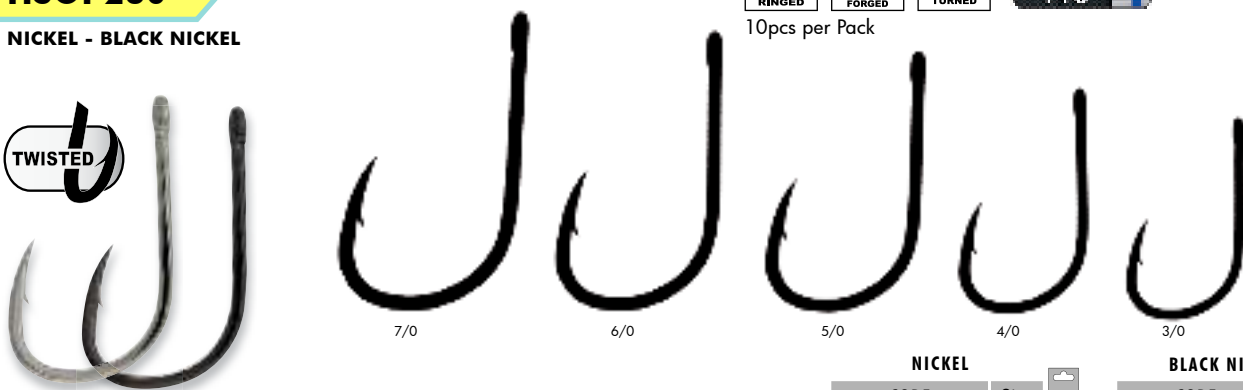

**NICKEL**

**BLACK NICKEL**

CODE	Size	PCS
HAYAM230N70	7/0	5
HAYAM230N60	6/0	5
HAYAM230N50	5/0	6
HAYAM230N40	4/0	7
HAYAM230N30	3/0	7

CODE	Size	PCS
HAYAM230BN70	7/0	5
HAYAM230BN60	6/0	5
HAYAM230BN50	5/0	6
HAYAM230BN40	4/0	7
HAYAM230BN30	3/0	7

Amo forgiato storto robustissimo e leggero. Realizzato per l'innesci di esche vive per la traina come calamari, sugarelli seppie e aguglie, ideale per insidiare grosse prede.

Forged eyed hook with slightly bent point. For use with live bait for trolling and drifting.

### HBST 563

BLACK NICKEL



10pcs per Pack

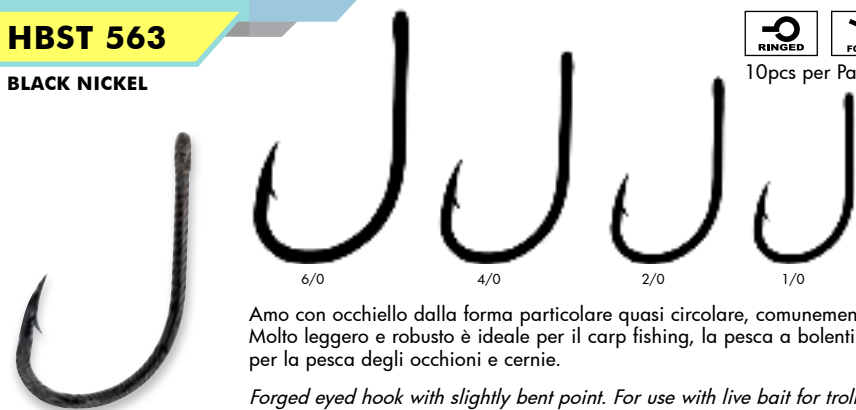

Amo con occhiello dalla forma particolare quasi circolare, comunemente chiamato auto ferrante. Molto leggero e robusto è ideale per il carp fishing, la pesca a bolentino e bolentino di fondale, per la pesca degli occhioni e cernie.

Forged eyed hook with slightly bent point. For use with live bait for trolling and drifting..

CODE	Size	PCS
HAYAM563BN60	6/0	4
HAYAM563BN40	4/0	5
HAYAM563BN20	2/0	6
HAYAM563BN10	1/0	7



**HCRL 186**
**BLACK NICKEL**

10pcs per Pack

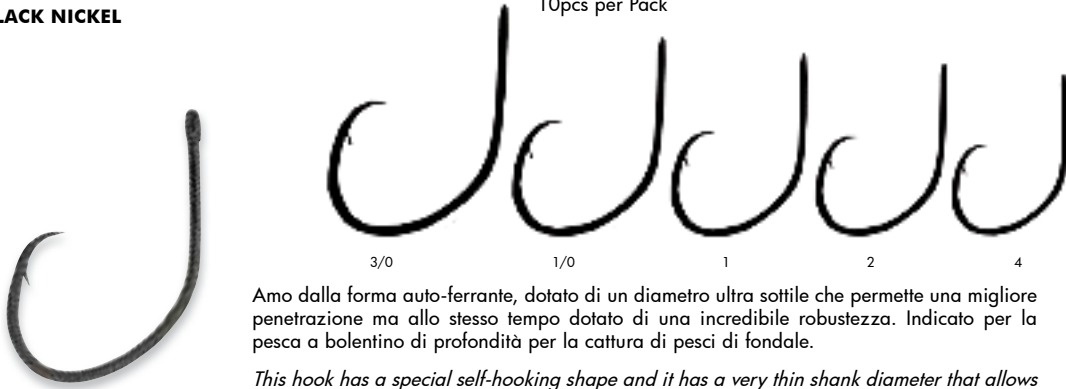

Amo dalla forma auto-ferrante, dotato di un diametro ultra sottile che permette una migliore penetrazione ma allo stesso tempo dotato di una incredibile robustezza. Indicato per la pesca a bolentino di profondità per la cattura di pesci di fondale.

*This hook has a special self-hooking shape and it has a very thin shank diameter that allows a better penetration but yet performing an incredible strength. Recommended of the deep bottom sea fishing.*

CODE	Size	PCS
HAYAM186BN30	3/0	5
HAYAM186BN10	1/0	7
HAYAM186BN01	1	8
HAYAM186BN02	2	10
HAYAM186BN04	4	12

**HBEK 562**
**NICKEL - BLACK NICKEL**

10pcs per Pack

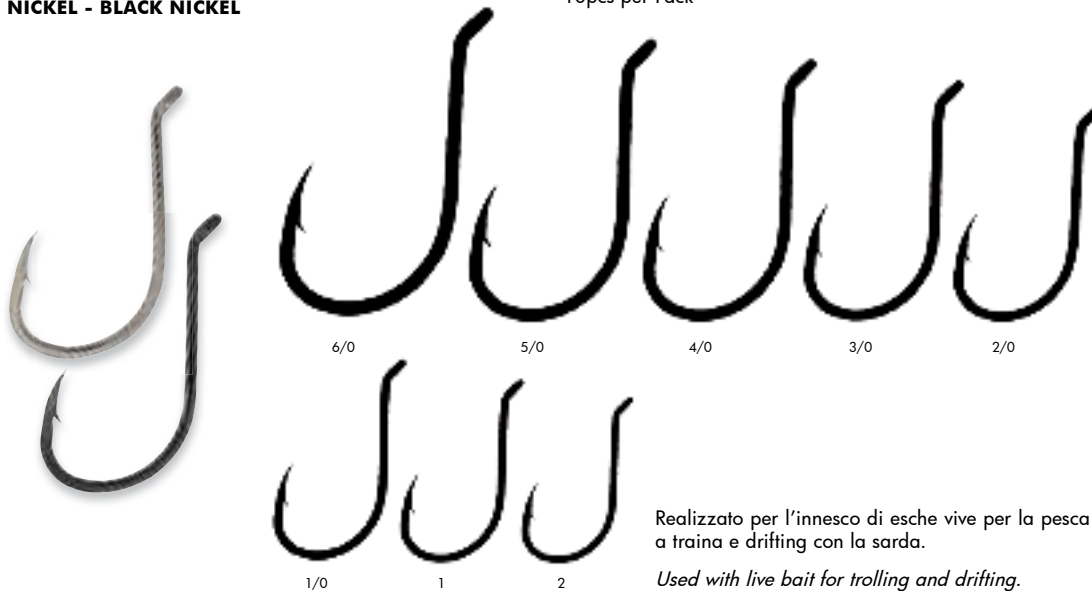
**NICKEL**

CODE	Size	PCS
HAYAM562N60	6/0	4
HAYAM562N50	5/0	4
HAYAM562N40	4/0	5
HAYAM562N30	3/0	5
HAYAM562N20	2/0	6
HAYAM562N10	1/0	6
HAYAM562N01	1	8
HAYAM562N02	2	8

**BLACK NICKEL**

CODE	Size	PCS
HAYAM562BN60	6/0	4
HAYAM562BN50	5/0	4
HAYAM562BN40	4/0	5
HAYAM562BN30	3/0	5
HAYAM562BN20	2/0	6
HAYAM562BN10	1/0	6
HAYAM562BN01	1	8
HAYAM562BN02	2	8

Realizzato per l'innescio di esche vive per la pesca a traina e drifting con la sarda.

*Used with live bait for trolling and drifting.*

**HCRL 187**
**BLACK NICKEL**

10pcs per Pack



Amo forgiato con occhiello, il massimo della robustezza. Realizzato per l'innescio di grosse esche per la pesca di fondale alle grandi cernie e squali di fondale.

*Bent eyed hook with particular shape, almost circular, gives instant penetration. Ultra-lightweight and strong, it is ideal for trolling and deep trolling for red sea-bream.*

CODE	Size	PCS
HAYAM187BN40	4/0	2
HAYAM187BN20	2/0	3
HAYAM187BN01	1	4

# Hayabusa



## HMAG 188

BLACK NICKEL



10pcs per Pack

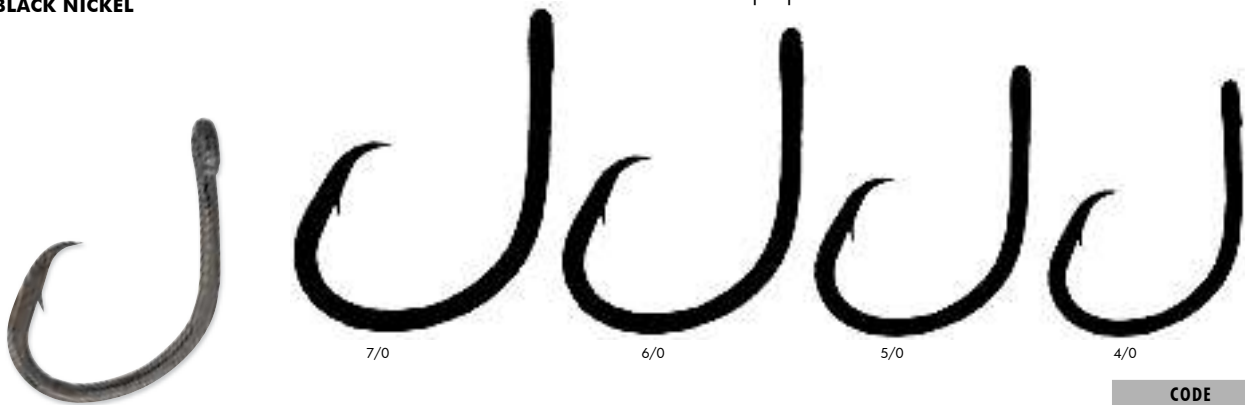

Amo con occhiello realizzato per la pesca al tonno allo spada ed a tutte le grosse prede del big game.

*Bent eyed hook made for tuna and swordfish fishing and for all big game fishes.*

CODE	Size	PCS
HAYAM188BN70	7/0	3
HAYAM188BN60	6/0	3
HAYAM188BN50	5/0	3
HAYAM188BN40	4/0	3

## HLBT 571

BLACK NICKEL



10pcs per Pack

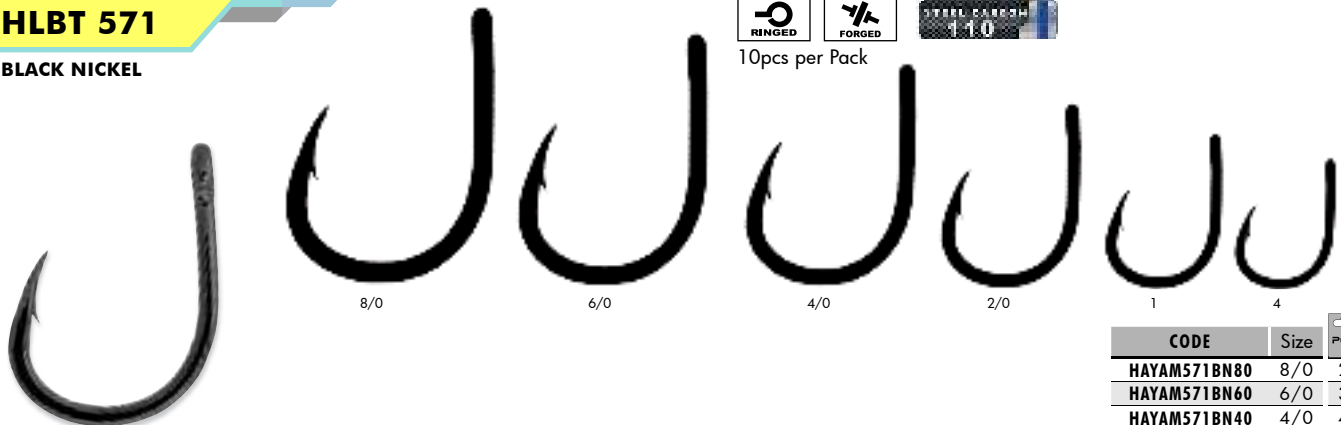

Realizzato per la pesca al tonno ai pesci spada ed a tutte le grosse prede del big game e bolentino di fondale.

*Forged, straight eyed hook for tuna and swordfish fishing, as well as for all big game fishes.*

CODE	Size	PCS
HAYAM571BN80	8/0	2
HAYAM571BN60	6/0	3
HAYAM571BN40	4/0	4
HAYAM571BN20	2/0	5
HAYAM571BN01	1	6
HAYAM571BN04	4	7

# ASSIST HOOKS SPECIAL JIGGING

Nel mondo della pesca a "Vertical Jigging" c'è una ricerca continua nel trovare in commercio, ami con punta affilata chimicamente montati professionalmente con materiali di primissima qualità. Multifibra tubolare, treccia, solid ring in acciaio sono alcuni dei materiali usati nella costruzione per poter esaltare resistenza e qualità del prodotto.

*In the "Vertical Jigging" fishing world there is a continuous research for hooks with a chemically sharpened tip mounted professionally with high quality materials. Tubular multi-fibre, braid, and steel solid ring are some of materials used in the process to exalt resistance and quality of the product.*

## POWER ASSIST HOOK

**LONG BRAID - SOLID RING**  
**BRAID LENGTH 60MM**

2pcs per Bag - 10pcs per Pack

CODE	Size	Pe Line
ASSPL90	9/0	250 Lbs
ASSPL70	7/0	250 Lbs



## POWER ASSIST HOOK

**SHORT BRAID - SOLID RING**  
**BRAID LENGTH 22MM**

2pcs per Bag - 10pcs per Pack

CODE	Size	Pe Line
ASSPS90	9/0	250 Lbs
ASSPS70	7/0	250 Lbs



## SINGLE ASSIST SKIN

**LONG BRAID - SOLID RING**  
**BRAID LENGTH 60MM**

2pcs per Bag - 10pcs per Pack

CODE	Size	Braid Line	Pe Line
ASSSK90	9/0	52mm	250 Lbs
ASSSK70	7/0	38mm	250 Lbs
ASSSK50	5/0	42mm	250 Lbs
ASSSK30	3/0	35mm	250 Lbs



## SINGLE ASSIST HOOK

**LONG BRAID**  
**BRAID LENGTH 60MM**

2pcs per Bag - 10pcs per Pack

CODE	Size	Pe Line
ASSSL90	9/0	250 Lbs
ASSSL70	7/0	250 Lbs
ASSSL50	5/0	250 Lbs



## TWIN ASSIST HOOK

**LONG BRAID - SOLID RING**  
**BRAID LENGTH 60MM**

2pcs per Bag - 10pcs per Pack

CODE	Size	Braid Line	Pe Line
ASSTSR50	5/0	20/40mm	250 Lbs
ASSTSR70	7/0	22/44mm	250 Lbs



## SINGLE ASSIST GLOW

**LONG BRAID - SOLID RING**  
**BRAID LENGTH 60MM**

2pcs per Bag - 10pcs per Pack

CODE	Size	Braid Line	Pe Line
ASSSG90	9/0	52mm	250 Lbs
ASSSG70	7/0	38mm	250 Lbs
ASSSG50	5/0	42mm	250 Lbs



# SNELLED HOOKS

Ogni amo è stato minuziosamente montato a mano e sottoposto al controllo di qualità più severo per garantire un prodotto di massima affidabilità. Tutte le confezioni sono da 5 pezzi ed hanno 8 ami legati per Packcino.

*Each hook is carefully tied by hand and thanks to a rigorous individual inspection procedure we achieve a perfect product that can be relied upon every time. All the trade packs are from 5 pieces and have 8 snelled hooks for card.*



## N500

LENGTH 70CM

 8pcs per Bag  
5pcs per Pack

CODE	Size	Line Ømm
AL10416	4	0,16
AL10418	4	0,18
AL10420	4	0,20
AL10616	6	0,16
AL10618	6	0,18
AL10620	6	0,20

CODE	Size	Line Ømm
AL10814	8	0,14
AL10816	8	0,16
AL10818	8	0,18
AL11012	10	0,12
AL11014	10	0,14
AL11016	10	0,16
AL11212	12	0,12
AL11214	12	0,14
AL11216	12	0,16
AL11412	14	0,12
AL11414	14	0,14
AL11416	14	0,16
AL11610	16	0,10
AL11612	16	0,12
AL11614	16	0,14

## N600

LENGTH 70CM

 8pcs per Bag  
5pcs per Pack

CODE	Size	Line Ømm
AL20616	6	0,16
AL20618	6	0,18
AL20620	6	0,20
AL20814	8	0,14
AL20816	8	0,16
AL20818	8	0,18
AL21014	10	0,14
AL21016	10	0,16
AL21018	10	0,18

CODE	Size	Line Ømm
AL21212	12	0,12
AL21214	12	0,14
AL21216	12	0,16
AL21412	14	0,12
AL21414	14	0,14
AL21416	14	0,16
AL21610	16	0,10
AL21612	16	0,12
AL21614	16	0,14
AL21810	18	0,10
AL21812	18	0,12
AL22008	20	0,08
AL22010	20	0,10

## N957

LENGTH 70CM

 8pcs per Bag  
5pcs per Pack

CODE	Size	Line Ømm
AL31212	12	0,12
AL31214	12	0,14

CODE	Size	Line Ømm
AL31410	14	0,10
AL31412	14	0,12
AL31414	14	0,14
AL31610	16	0,10
AL31612	16	0,12
AL31808	18	0,08
AL31810	18	0,10
AL31812	18	0,12
AL32008	20	0,08
AL32010	20	0,10
AL32208	22	0,08
AL32210	22	0,10

## NK800

LENGTH 70CM

 8pcs per Bag  
5pcs per Pack

CODE	Size	Line Ømm
AL40418	4	0,18
AL40420	4	0,20
AL40616	6	0,16
AL40618	6	0,18
AL40814	8	0,14
AL40816	8	0,16
AL40818	8	0,18
AL41014	10	0,14
AL41016	10	0,16
AL41018	10	0,18
AL41212	12	0,12
AL41214	12	0,14
AL41216	12	0,16

## MR300

LENGTH 150CM

8pcs per Bag - 5pcs per Pack



CODE	Size	Line Ømm
AL60425	4	0,25
AL60430	4	0,30
AL60622	6	0,22
AL60625	6	0,25
AL60628	6	0,28
AL60818	8	0,18
AL60820	8	0,20
AL60823	8	0,23
AL61016	10	0,16
AL61018	10	0,18
AL61020	10	0,20
AL61214	12	0,14
AL61216	12	0,16
AL61218	12	0,18

## N600 TROUT

LENGTH 200CM

 8pcs per Bag  
5pcs per Pack

CODE	Size	Line Ømm
AL70616	6	0,16
AL70618	6	0,18
AL70620	6	0,20
AL70814	8	0,14
AL70816	8	0,16
AL70818	8	0,18
AL71014	10	0,14
AL71016	10	0,16

## WN501

LENGTH 70CM

 8pcs per Bag  
5pcs per Pack

CODE	Size	Line Ømm
AL51216	12	0,16
AL51218	12	0,18
AL51414	14	0,14
AL51416	14	0,16
AL51614	16	0,14
AL51616	16	0,16
AL51814	18	0,14

## CARPA & RIVER

Finali da competizione realizzati per le molteplici esigenze della pesca sportiva. Sono muniti di asola per la connessione diretta alla lenza madre. Lunghezza 30 cm

Competition hooks created for the multiple demands of anglers. Complete with eye for attaching directly to the main line. Length 30 cm.



### CARP CR830



8pcs per Bag  
10pcs per Pack

CODE	Size	Line Ømm
<del>ALCR83005</del>	10	0,16
<del>ALCR83006</del>	12	0,18
<del>ALCR83007</del>	12	0,16
ALCR83008	12	0,14
ALCR83009	14	0,16
<del>ALCR83010</del>	14	0,14
ALCR83011	16	0,14
<del>ALCR83012</del>	16	0,12
<del>ALCR83013</del>	18	0,14
<del>ALCR83014</del>	18	0,12

### CARP CR721



8pcs per Bag  
10pcs per Pack

CODE	Size	Line Ømm
ALCR72114	14	0,14
ALCR72115	16	0,14
ALCR72116	16	0,12

### RIVER RV703



8pcs per Bag  
10pcs per Pack

**SOLD OUT**

### RIVER RV696



8pcs per Bag  
10pcs per Pack

CODE	Size	Line Ømm
<del>ALRV69602</del>	12	0,12
<del>ALRV69604</del>	14	0,12
<del>ALRV69605</del>	16	0,14
<del>ALRV69606</del>	16	0,12
ALRV69607	16	0,10
<del>ALRV69608</del>	18	0,12
ALRV69609	18	0,10

### CARP CR130



8pcs per Bag  
10pcs per Pack

CODE	Size	Line Ømm
ALCR13011	14	0,14
ALCR13014	16	0,12

# SABIKI Hayabusa

## S500E (MIX-YARN)

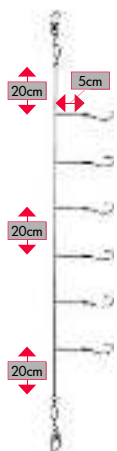

6pcs per Bag  
10pcs per Pack

**EUROPEAN SIZE**

CODE	Japan	Hooks	Main Line	Branch
HAYAS50006	6	10	1,40mt/0,29mm	0,21mm
HAYAS50008	8	7	1,40mt/0,33mm	0,24mm



## S501E (MIX-YARN)

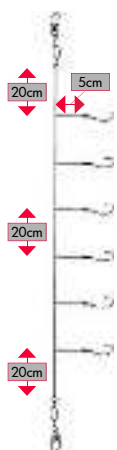

6pcs per Bag  
10pcs per Pack

**EUROPEAN SIZE**

CODE	Japan	Hooks	Main Line	Branch
HAYAS50110	10	4	1,65mt/0,47mm	0,37mm
HAYAS50112	12	2	1,65mt/0,47mm	0,37mm



## S505E (MIX-FLASHER)

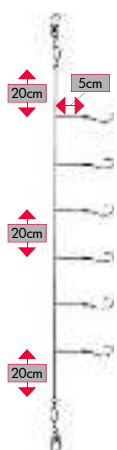

6pcs per Bag  
10pcs per Pack

**EUROPEAN SIZE**

CODE	Japan	Hooks	Main Line	Branch
HAYAS50508	8	7	1,40mt/0,33mm	0,24mm

**SOLD OUT**



## EX110 (SILVER-FISHSKIN)

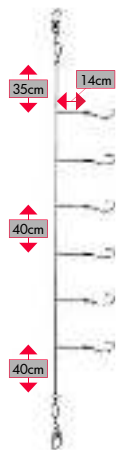

6pcs per Bag  
10pcs per Pack

### EUROPEAN SIZE

CODE	Japan	Hooks	Main Line	Branch
HAYAS11014	14	1	2,75mt/0,44mm	0,37mm



## HS401



HA	SOLD OUT	62	HAYAS40183
A	20		A 25
B	3		B 5
C	20		C 25
D	20		D 25

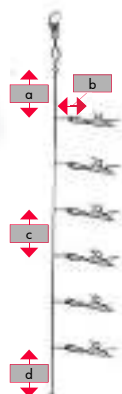

6pcs per Bag  
10pcs per Pack

### EUROPEAN SIZE

CODE	Japan	Hooks	Main Line	Branch
HA <b>SOLD OUT</b> 62	6-2-4	10	1,40mt/0,33mm	0,24mm
HAYAS40183	8-3-5	7	1,75mt/0,37mm	0,29mm



## EX111 (GOLD-FISHSKIN)

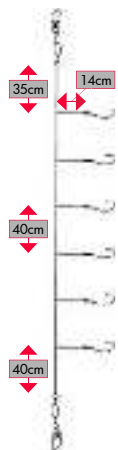

6pcs per Bag  
10pcs per Pack

### EUROPEAN SIZE

CODE	Japan	Hooks	Main Line	Branch
HAYAS11114	14	1	2,75mt/0,44mm	0,37mm



## HS420

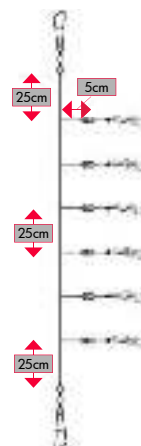

6pcs per Bag  
10pcs per Pack

### EUROPEAN SIZE

CODE	Japan	Hooks	Main Line	Branch
HAYAS42083	8-3-5	7	1,75mt/0,37mm	0,29mm

**SOLD OUT**



## EX120 (GOLD-FLASHER)

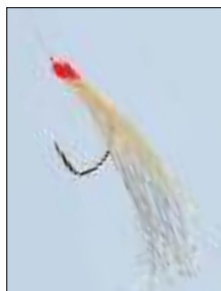
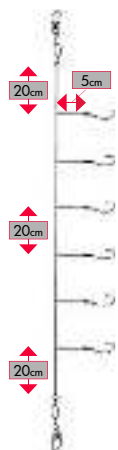

6pcs per Bag  
10pcs per Pack

### EUROPEAN SIZE

CODE	Japan	Hooks	Main Line	Branch
HAYAS120008	8	7	2,75mt/0,44mm	0,21mm
HAYAS120009	9	6	2,10mt/0,33mm	0,24mm



### HS425

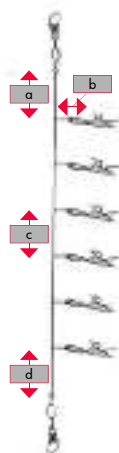

**HAYAS42562**

A	20
B	3
C	20
D	20

**HAYAS42563**

A	25
B	5
C	25
D	25



6pcs per Bag  
10pcs per Pack

**EUROPEAN SIZE**

CODE	Japan	Hooks	Main Line	Branch
HAYAS42562	6-2-4	10	1,40mt/0,33mm 0,24mm	
HAYAS42583	8-3-5	7	1,75mt/0,37mm 0,29mm	



### HS432

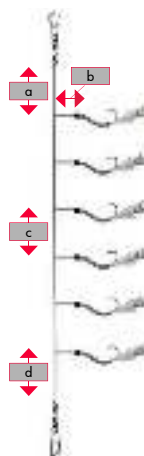

**HAYAS43262**

A	20
B	3
C	20
D	20

**HAYAS3263**

A	25
B	5
C	25
D	25



6pcs per Bag  
10pcs per Pack

**EUROPEAN SIZE**

CODE	Japan	Hooks	Main Line	Branch
HAYAS43262	6-2-4	10	1,40mt/0,33mm 0,24mm	
HAYAS43283	8-3-5	7	1,75mt/0,37mm 0,29mm	

**SOLD OUT**



### D151



5pcs per Bag  
10pcs per Pack

**EUROPEAN SIZE**

CODE	Japan	Hooks	Main Line	Branch
HAYAS15183	8-3-5	7	1,75mt/0,37mm 0,29mm	

**SOLD OUT**

### HS340

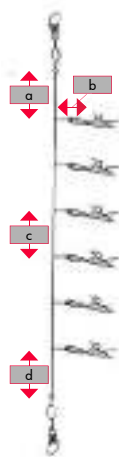

**HAYAS34061**

A	20
B	3
C	20
D	20

**HAYAS34082**

A	25
B	5
C	25
D	25



6pcs per Bag  
10pcs per Pack

**EUROPEAN SIZE**

CODE	Japan	Hooks	Main Line	Branch
HAYAS34061	6-1,5-3	10	1,40mt/0,29mm 0,21mm	
HAYAS34062	6-1-2	10	1,40mt/0,24mm 0,17mm	
HAYAS34082	8-2-4	7	1,75mt/0,33mm 0,24mm	





## HS351

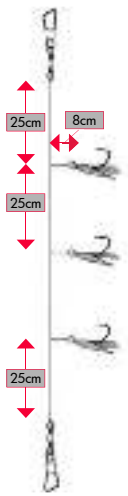

5pcs per Bag  
10pcs per Pack

### EUROPEAN SIZE

CODE	Japan	Hooks	Main Line	Branch
HAYAS35163	6-3-5	10	1,50mt/0,37mm	0,29mm
HAYAS43283	8-3-5	7	1,50mt/0,47mm	0,33mm

## HS352

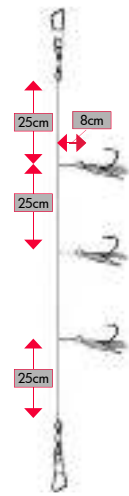

6pcs per Bag  
10pcs per Pack

### EUROPEAN SIZE

CODE	Japan	Hooks	Main Line	Branch
HAYAS35294	9-1-8-1	3	1,50mt/0,47mm	0,33mm

**SOLD OUT**

## HS712



6pcs per Bag  
10pcs per Pack

### EUROPEAN SIZE

CODE	Japan	Hooks	Main Line	Branch
<del>HAYAS71251</del>	5-1-2	12	1,40mt/0,25mm	0,17mm
<del>HAYAS71261</del>	6-1,5-3	10	1,40mt/0,29mm	0,21mm
<del>HAYAS71272</del>	7-2-4	8	1,40mt/0,33mm	0,24mm
<del>HAYAS71282</del>	8-2-4	7	1,75mt/0,33mm	0,24mm
HAYAS712103	10-3-5	4	1,75mt/0,37mm	0,29mm

## HS713



6pcs per Bag  
10pcs per Pack

### EUROPEAN SIZE

CODE	Japan	Hooks	Main Line	Branch
HAYAS71371	7-1,5-3	8	1,75mt/0,29mm	0,21mm
HAYAS71382	8-2-4	7	1,40mt/0,29mm	0,24mm
HAYAS71393	9-3-5	6	1,75mt/0,37mm	0,29mm

## HS714

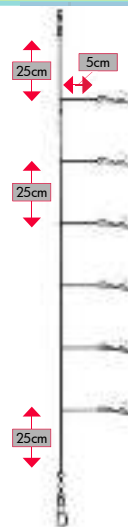

6pcs per Bag  
10pcs per Pack

### EUROPEAN SIZE

CODE	Japan	Hooks	Main Line	Branch
HAYAS71471	7-1,5-3	8	1,75mt/0,29mm	0,21mm
HAYAS71492	9-2-5	6	1,75mt/0,37mm	0,24mm

## HS715

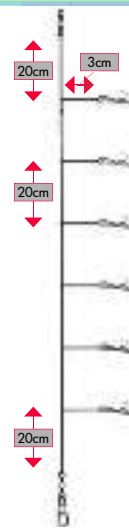

6pcs per Bag  
10pcs per Pack

### EUROPEAN SIZE

CODE	Japan	Hooks	Main Line	Branch
HAYAS71581	8-1,5-3	8	1,75mt/0,29mm	0,21mm

## VILMA

### COMPETITION - LAKE

Labels: HOLLOW PLASTIC, Balsa, Carbon

Size	0,20	0,30	0,50	0,75	1,00
Ant. Ø	1,50	1,50	1,50	1,50	1,50
Stem Ø	0,60	0,60	0,70	0,70	0,70

**CODE: GAVIL01**

## DUDDA

### COMPETITION - LAKE

Labels: HOLLOW PLASTIC + FIBERGLASS, Balsa, Carbon

Size	0,10	0,20	0,30	0,50	0,75	1,00
Ant. Ø	1,50	1,50	1,50	1,50	1,50	1,50
Stem Ø	0,70	0,70	0,70	0,70	0,70	0,70

**CODE: GADUD01**

## QUERCIA

### COMPETITION - LAKE

Labels: PLASTIC, Balsa, Carbon

Size	0,20	0,30	0,50	0,75	1,00
Ant. Ø	1,00	1,00	1,00	1,20	1,20
Stem Ø	0,60	0,60	0,60	0,70	0,70

**CODE: GAQUE01**

## SCACCIA

### COMPETITION - LAKE

Labels: PLASTIC, Carbon, Balsa, Carbon

Size	0,30	0,50	0,75	1,00	1,50	2,00
Ant. Ø	1,50	1,50	1,50	1,50	1,80	1,80
Stem Ø	0,70	0,70	0,70	0,70	0,80	0,80

**CODE: GASCA01**

## LIRI PASSANTE

### COMPETITION - LAKE

Labels: PLASTIC, Balsa, Carbon

Size	0,20	0,30	0,50	0,75	1,00	1,50	2,00
Ant. Ø	1,20	1,20	1,20	1,20	1,20	1,50	1,50
Stem Ø	0,60	0,60	0,60	0,70	0,70	0,70	0,80

**CODE: GALIR01**

# NEW FLOATS

Misura del galleggiante  
Float sizes

Size	0,10	0,20
Ant. Ø	1,50	1,50
Stem Ø	0,70	0,70

Misura dell'antenna  
Antenna sizes

Styl	gr.
4x8	0,060
4x10	0,12
4x12	0,212
4x14	0,328
4x16	0,512
4x18	0,704

Misura della deriva  
Stem sizes

Styl	gr.
4x20	1
5x20	1,25
6x20	1,50

## FILO PASSANTE LATERALE SIDE PASSING LINE

Quando si sposta il galleggiante,  
il nylon non segna la parete.  
*When you move the float,  
the nylon does not mark the wall.*



### SMASH PASSANTE

COMPETITION - LAKE

Size	0,30	0,50	0,75	1,00	1,50	2,00	3,00	4,00	5,00	6,00	8,00	10,00
Ant. Ø	1,50	1,50	1,50	1,50	1,50	1,50	1,80	1,80	1,80	1,80	2,00	2,00
Stem Ø	0,80	0,80	0,80	0,90	0,90	1,00	1,00	1,20	1,20	1,20	1,20	1,20

CODE: GASMA01

### VIPER

COMPETITION - LAKE

Size	0,20	0,30	0,50	0,75	1,00	1,25	1,50	2,00
Ant. Ø	0,80	0,80	0,80	0,80	0,90	0,90	1,00	1,00
Stem Ø	0,50	0,50	0,50	0,50	0,50	0,60	0,60	0,60

CODE: GAVIP01

### APACHE PASSANTE

COMPETITION - LAKE

Size	0,30	0,50	0,75	1,00	1,50	2,00	3,00	4,00	5,00	6,00	8,00
Ant. Ø	0,80	0,80	0,90	0,90	0,90	1,00	1,00	1,00	1,20	1,20	1,20
Stem Ø	0,60	0,60	0,60	0,70	0,70	0,70	0,80	0,80	0,80	0,90	0,90

CODE: GAAPA01

### MALAGA

COMPETITION - LAKE

Size	0,50	0,75	1,00	1,50	2,00	3,00
Ant. Ø	1,50	1,50	1,50	1,80	1,80	2,00
Stem Ø	0,70	0,70	0,80	0,80	0,80	0,90

CODE: GAMAL01

### LONDON PASSANTE

COMPETITION - LAKE

Size	0,10	0,20	0,30	0,50	0,75	1,00
Ant. Ø	2,00	2,00	2,00	2,00	2,00	2,00
Stem Ø	0,80	0,80	0,80	0,80	1,00	1,00

CODE: GALON01

## FURY PASSANTE

### COMPETITION - LAKE

**CODE: GAFUR01**

Size	0,10	0,20	0,30	0,50	0,75	1,00
Ant. Ø	2,20	2,20	2,20	2,20	2,20	2,20
Stem Ø	0,80	0,80	0,80	0,80	1,00	1,00

## TOLOSA PASSANTE

### COMPETITION - LAKE

**CODE: GATOL01**

Size	0,10	0,20	0,30	0,50	0,75	1,00
Ant. Ø	3,00	3,00	3,00	3,00	3,00	3,00
Stem Ø	0,80	0,80	0,80	0,80	1,00	1,00

## LIONE PASSANTE

### COMPETITION - LAKE

**CODE: GALIO01A**

Size	0,20	0,30	0,50	0,75	1,00
Ant. Ø	3,00	3,00	3,00	3,00	3,00
Stem Ø	0,80	0,80	0,80	0,80	1,00

## POSEIDON PASSANTE

### SPECIAL SEA

**CODE: GAPOS01**

Size	0,30	0,50	0,75	1,00	1,50	2,00	3,00	4,00	5,00	6,00
Ant. Ø	3,00	3,00	3,00	3,00	3,00	4,50	4,50	4,50	4,50	4,50
Stem Ø	0,80	0,80	0,80	0,80	0,90	0,90	1,00	1,00	1,00	1,00

## TRITON PASSANTE

### SPECIAL SEA

**CODE: GATRI01**

Size	0,30	0,50	0,75	1,00	1,50	2,00	3,00	4,00	5,00	6,00
Ant. Ø	3,00	3,00	3,00	3,00	3,00	4,50	4,50	4,50	4,50	4,50
Stem Ø	0,80	0,80	0,80	0,80	0,90	0,90	1,00	1,00	1,00	1,00

# NEW FLOATS

## SAAR

### SPECIALE BOLO



CODE: GASAA01

Size	6,00	8,00	10,00	12,00	14,00	16,00	18,00	20,00
Ant. Ø	2,50	2,50	2,50	3,00	3,00	3,00	3,00	3,00
Stem Ø	1,20	1,20	1,50	1,50	1,50	1,50	1,50	1,50

## SPRE PASSANTE

### SPECIALE BOLO



CODE: GASPR01

Size	10,00	12,00	14,00	16,00	20,00
Ant. Ø	3,00	3,00	3,00	3,00	3,00
Stem Ø	1,50	1,50	1,50	1,50	1,50

## SILO

### SPECIALE BOLO



CODE: GASIL02

Size	6,00	8,00	10,00	12,00	14,00	16,00	18,00
Ant. Ø	2,50	2,50	2,50	3,00	3,00	3,00	3,00
Stem Ø	1,20	1,20	1,50	1,50	1,50	1,50	1,50



## PERLA

Labels: HOLLOW PLASTIC, Balsa, CARBON

Size	0,10	0,20	0,30	0,50	0,75	1,00	1,50
Ant. Ø	1,50	1,50	1,50	1,50	1,50	1,50	1,50
Stem Ø	0,70	0,70	0,70	0,70	0,70	0,70	0,70

**CODE: GAPER**

## DIEGO

Labels: HOLLOW PLASTIC, Balsa, CARBON

Size	0,10	0,20	0,30	0,50	0,75	1,00	1,50	2,00
Ant. Ø	1,50	1,50	1,50	1,50	1,50	1,50	1,50	1,50
Stem Ø	0,70	0,70	0,70	0,70	0,70	0,70	0,70	0,70

**CODE: GADIE**

## BRUNO

Labels: HOLLOW PLASTIC, Balsa, CARBON

Size	0,10	0,20	0,30	0,50	0,75	1,00	1,50	2,00
Ant. Ø	1,50	1,50	1,50	1,50	1,50	1,50	1,50	1,50
Stem Ø	0,70	0,70	0,70	0,70	0,70	0,70	0,70	0,70

**CODE: GABRU**

## FILO PASSANTE LATERALE

### SIDE PASSING LINE

Quando si sposta il galleggiante, il nylon non segna la parete.

*When you move the float, the nylon does not mark the wall.*

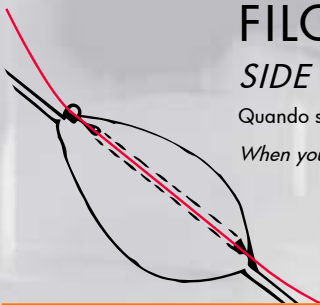

## SCOLMATORE PASSANTE

Labels: HOLLOW PLASTIC, Balsa, CARBON

Size	0,20	0,30	0,50	0,75	1,00	1,50	2,00
Ant. Ø	1,20	1,20	1,20	1,20	1,50	1,50	1,50
Stem Ø	0,70	0,70	0,70	0,70	0,80	0,80	0,80

**CODE: GASCO**

## PO PASSANTE

Labels: HOLLOW PLASTIC + FIBERGLASS, Balsa, CARBON

Size	0,20	0,30	0,50	0,75	1,00	1,50	2,00	2,50	3,00	4,00	5,00
Ant. Ø	1,50	1,50	1,50	1,50	1,50	1,70	1,70	1,80	1,80	1,80	1,80
Stem Ø	0,60	0,60	0,70	0,70	0,70	0,80	0,80	0,80	0,80	0,90	0,90

**CODE: GAPOO**

## VAGGIO PASSANTE

Diagram labels: HOLLOW PLASTIC + FIBERGLASS, BALSА, CARBON

CODE: GAVAG

Size	0,20	0,30	0,50	0,75	1,00	1,50
Ant. Ø	1,50	1,50	1,50	1,50	1,70	1,70
Stem Ø	0,70	0,70	0,70	0,70	0,80	0,80

## GUADIANA PASSANTE

Diagram labels: HOLLOW PLASTIC + FIBERGLASS, BALSА, CARBON

CODE: GAGUA

Size	0,20	0,30	0,50	0,75	1,00	1,50	2,00	3,00
Ant. Ø	1,20	1,20	1,20	1,20	1,20	1,20	1,20	1,20
Stem Ø	0,60	0,60	0,60	0,70	0,70	0,80	0,80	0,80

## MERIDA PASSANTE

Diagram labels: HOLLOW PLASTIC + FIBERGLASS, BALSА, CARBON

CODE: GAMER

Size	0,20	0,30	0,50	0,75	1,00	1,50	2,00	3,00
Ant. Ø	1,20	1,20	1,20	1,20	1,20	1,20	1,20	1,20
Stem Ø	0,60	0,60	0,60	0,70	0,70	0,80	0,80	0,80

## ARNO PASSANTE

Diagram labels: PLASTIC, BALSА, STEEL

CODE: GAARN

Size	0,20	0,30	0,50	0,75	1,00	1,50	2,00	2,50	3,00
Ant. Ø	1,00	1,00	1,00	1,00	1,20	1,20	1,20	1,20	1,20
Stem Ø	0,50	0,50	0,50	0,50	0,60	0,60	0,60	0,60	0,70

**SOLD OUT**

## METAURO PASSANTE

Diagram labels: PLASTIC, BALSА, STEEL

CODE: GAMET

Size	0,20	0,30	0,50	0,75	1,00	1,50	2,00	2,50	3,00	4,00	5,00	6,00	8,00	10,00
Ant. Ø	1,00	1,00	1,00	1,00	1,20	1,20	1,20	1,20	1,20	1,50	1,50	1,80	1,80	2,00
Stem Ø	0,50	0,50	0,50	0,50	0,60	0,60	0,60	0,60	0,60	0,70	0,70	0,80	0,80	0,80

## STREAM PASSANTE

Diagram labels: PLASTIC, BALSА, STEEL

CODE: GASTR

Size	4x20	1,50	2,00	2,50	3,00	4,00	5,00	6,00	8,00	10,0	12,0	15,0
Ant. Ø	1,20	1,50	1,50	1,50	1,80	1,80	1,80	2,00	2,00	2,00	2,00	2,00
Stem Ø	0,60	0,70	0,70	0,70	0,80	0,90	0,90	1,00	1,00	1,00	1,00	1,00

## MENTA PISA

**CODE: GAMEP**

Size	1,00	1,50	2,00	3,00	4,00	5,00	6,00	8,00	10,00	12,00	15,00	20,00
Ant. Ø	1,50	1,50	1,50	2,00	2,00	2,00	2,00	2,20	2,50	2,50	2,50	2,50
Stem Ø	0,90	0,90	0,90	1,00	1,00	1,00	1,00	1,20	1,20	1,20	1,20	1,20

## CASTELFRANCO PASSANTE

**CODE: GACAST**

Size	1,0	1,5	2,0	3,0	4,0	5,0	6,0	8,0
Ant. Ø	1,5	1,5	1,5	1,5	1,5	2,0	2,0	2,0
Stem Ø	0,90	0,90	0,90	1,00	1,00	1,00	1,00	1,20



## SPECIALCARP PASSANTE

**CODE: GASPEC05**

Size	0,10	0,20	0,30	0,50	0,7	1,0
An	0,70	0,70	0,70	0,70	0,70	0,70
Stem Ø	1,20	1,2	1,2	1,2	1,2	1,2

## MARGIN PASSANTE

**CODE: GAMAR05**

Size	0,10	0,20	0,30	0,50	0,75	1,00
Ant. Ø	0,7	0,7	0,7	0,7	0,7	0,7
Stem Ø	1,20	1,20	1,20	1,20	1,20	1,20



## MOON PASSANTE



Size	<b>SOLD OUT</b> 0,10	0,20	0,30
Ant. Ø	0,60	0,60	0,60
Stem Ø	0,60	0,60	0,70

CODE: GAMOO

## STORM PASSANTE

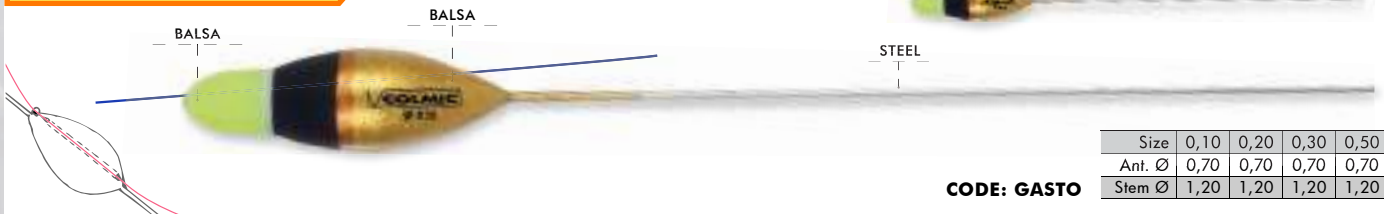

Size	0,10	0,20	0,30	0,50
Ant. Ø	0,70	0,70	0,70	0,70
Stem Ø	1,20	1,20	1,20	1,20

CODE: GASTO

## PINO PIOMBATO



Size	0,20	0,30
Ant. Ø	2,00	2,00
Stem Ø	0,70	0,80

CODE: GAPIN01

## COLOGNOLE PIOMBATO



Size	0,20	0,30
Ant. Ø	2,00	2,00
Stem Ø	0,70	0,80

CODE: GACOG01

## PROFESSIONAL PASSANTE

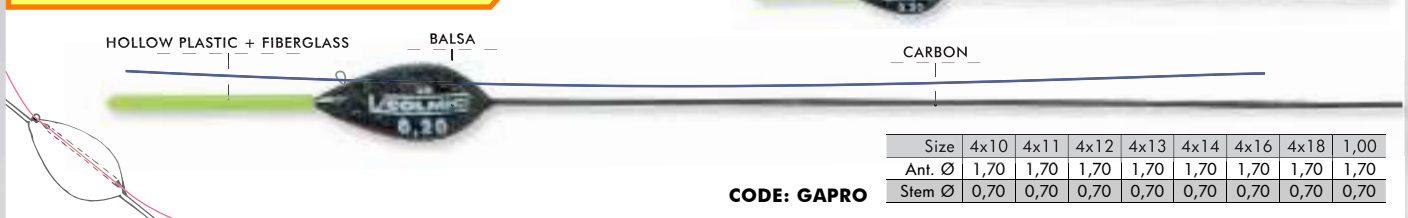

Size	4x10	4x11	4x12	4x13	4x14	4x16	4x18	1,00
Ant. Ø	1,70	1,70	1,70	1,70	1,70	1,70	1,70	1,70
Stem Ø	0,70	0,70	0,70	0,70	0,70	0,70	0,70	0,70

CODE: GAPRO

## SPECIALIST PASSANTE

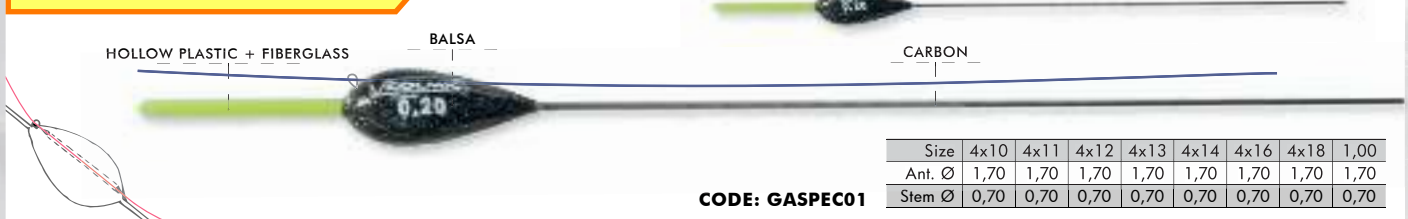

Size	4x10	4x11	4x12	4x13	4x14	4x16	4x18	1,00
Ant. Ø	1,70	1,70	1,70	1,70	1,70	1,70	1,70	1,70
Stem Ø	0,70	0,70	0,70	0,70	0,70	0,70	0,70	0,70

CODE: GASPEC01

**GALAXY PASSANTE**

PLASTIC BALSIA FIBER GLASS

ADDITIONAL PACK: ONLY RED ANTENNA

CODE: **G** SOLD OUT E  
CODE: **GAGAL**

Size	0,10	0,20	0,30	0,50	0,75	1,00	1,50
Ant. Ø	3,00	3,00	3,00	3,00	3,00	3,00	3,00
Stem Ø	0,80	0,80	0,80	1,00	1,00	1,00	1,00

**RED DEVIL PASSANTE**

PLASTIC BALSIA CARBON

NO RING

CODE: **GARED**

Size	0,10	0,20	0,30	0,50	0,75	1,00
Ant. Ø	2,00	2,00	2,00	2,00	2,00	2,00
Stem Ø	0,70	0,70	0,70	0,70	0,80	0,80

**BLACK DEVIL PASSANTE**

PLASTIC BALSIA CARBON

NO RING

CODE: **GABLA**

Size	0,10	0,20	0,30	0,50	0,75	1,00
Ant. Ø	1,50	1,50	1,50	1,50	1,70	1,70
Stem Ø	0,70	0,70	0,70	0,70	0,80	0,80

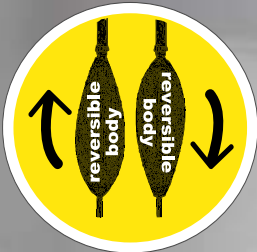

**REVERSIBLE BODY**

Filo passante interno con supporto in guaina.  
Internal line loop with protective sheath support.

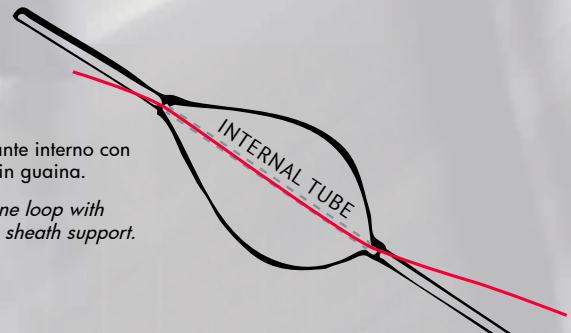

**KONAN PASSANTE**

HOLLOW PLASTIC BALSIA CARBON

ADDITIONAL PACK: ONLY RED ANTENNA

Code: **G** SOLD OUT E  
Code: **GAKON**

Size	0,10	0,20	0,30	0,50	0,75	1,00
Ant. Ø	2,00	2,00	2,00	2,00	2,00	2,00
Stem Ø	0,90	0,90	0,90	0,90	0,90	0,90

**KOY PASSANTE**

HOLLOW PLASTIC BALSIA CARBON

ADDITIONAL PACK: ONLY RED ANTENNA

Code: **G** SOLD OUT E  
Code: **GAKOY**

Size	0,10	0,20	0,30	0,50	0,75	1,00	1,50	2,00	2,50	3,00
Ant. Ø	2,00	2,00	2,00	2,00	2,00	2,00	2,00	2,00	2,00	2,00
Stem Ø	0,90	0,90	0,90	0,90	0,90	0,90	0,90	0,90	0,90	0,90

# COMPETITION - LAKE

## SKY PASSANTE



ADDITIONAL PACK: ONLY RED ANTENNA

Code: **GASOLD OUT**  
Code: **GASKY**

Size	0,10	0,20	0,30	0,50	0,75	1,00	1,50
Ant. Ø	1,50	1,50	1,50	1,50	1,50	1,50	1,50
Stem Ø	0,90	0,90	0,90	0,90	0,90	0,90	0,90

## MIKE PASSANTE



ADDITIONAL PACK: ONLY RED ANTENNA

Code: **GASOLD OUT**  
Code: **GAMIKRE**

Size	0,10	0,20	0,30	0,50	0,75	1,00	1,50
Ant. Ø	1,50	1,50	1,50	1,50	1,50	1,50	1,50
Stem Ø	0,90	0,90	0,90	0,90	0,90	0,90	0,90

## X-FORCE PASSANTE



ADDITIONAL PACK: ONLY RED ANTENNA

Code: **GASOLD OUT**  
Code: **GAXFO**

Size	0,20	0,30	0,50	0,75	1,00	1,50	2,00	3,00
Ant. Ø	1,50	1,50	1,50	1,50	1,50	1,80	1,80	2,00
Stem Ø	0,80	0,80	0,80	0,80	0,80	0,80	0,80	1,00

## MAGIC PASSANTE



CODE: **GAMAG**

**SOLD OUT**

Size	0,10	0,20	0,30	0,50	1,00	1,50	2,00
Ant. Ø	1,50	1,50	1,50	1,50	1,50	1,50	1,50
Stem Ø	0,90	0,90	0,90	0,90	0,90	0,80	0,80

## JOKER PASSANTE



CODE: **GAJOK**

**SOLD OUT**

Size	0,20	0,30	0,50	1,00	2,00	3,00
Ant. Ø	1,20	1,20	1,20	1,20	1,50	1,50
Stem Ø	0,60	0,60	0,60	0,60	0,80	0,80

## PULSAR PASSANTE



CODE: **GAPUL**

Size	0,10	0,20	0,30	0,50	0,75	1,00
Ant. Ø	1,80	1,80	1,80	1,80	1,80	1,80
Stem Ø	0,70	0,70	0,70	0,70	0,70	0,70

## CREXY PASSANTE

**CODE: GACRE**

Size	0,10	0,20	0,30	0,50	0,75	1,00
Ant. Ø	1,80	1,80	1,80	1,80	1,80	1,80
Stem Ø	0,70	0,70	0,70	0,70	0,70	0,70

## PECCI PASSANTE

**CODE: GAPEC01**

Size	0,10	0,20	0,30	0,50	0,75	1,00
Ant. Ø	1,50	1,50	1,50	1,50	1,50	1,80
Stem Ø	0,80	0,80	0,80	0,80	0,80	0,80

## AGLIANA PASSANTE

**CODE: GAAGLI01**

Size	0,10	0,20	0,30	0,50	0,75	1,00	1,50	2,00
Ant. Ø	1,50	1,50	1,50	1,50	1,50	1,80	1,80	1,80
Stem Ø	0,80	0,80	0,80	0,80	0,80	0,80	0,80	0,80

## RICCA

**CODE: GARIC**

Size	4x12	4x14	4x16	4x18	1,00	1,50
Ant. Ø	1,50	1,50	1,50	1,50	1,80	1,80
Stem Ø	0,70	0,70	0,70	0,70	0,80	0,80

## MATTE

**CODE: GAMAT**

Size	4x12	4x14	4x16	4x18	1,00	1,50
Ant. Ø	1,50	1,50	1,50	1,50	1,50	1,80
Stem Ø	0,60	0,60	0,70	0,70	0,80	0,80

## SMERALDO

**CODE: GASME**

Size	4x8	4x12	4x14	4x16	4x18	1,00
Ant. Ø	1,00	1,00	1,00	1,00	1,00	1,00
Stem Ø	0,60	0,60	0,60	0,60	0,60	0,70

# COMPETITION - LAKE

## ELSA



Size	4x8	4x10	4x12	4x14	4x16	4x18	1,00
Ant. Ø	1,20	1,20	1,20	1,20	1,20	1,20	1,20
Stem Ø	0,60	0,60	0,60	0,60	0,60	0,60	0,60

CODE: GAELSEB

## OMBRONE



Size	4x8	4x10	4x12	4x14	4x16	4x18	1,00
Ant. Ø	1,20	1,20	1,20	1,20	1,20	1,20	1,20
Stem Ø	0,60	0,60	0,60	0,60	0,60	0,60	0,60

CODE: GAE0MB

## LORY



Size	0,20	0,30	0,50	0,75	1,00	1,50
Ant. Ø	1,50	1,50	1,50	1,50	1,80	1,80
Stem Ø	0,60	0,60	0,60	0,60	0,70	0,70

CODE: GALOR

## GRANADA



Size	0,50	0,75	1,00	1,50	2,00	2,50	3,00
Ant. Ø	1,20	1,20	1,20	1,20	1,50	1,50	1,50
Stem Ø	0,70	0,70	0,70	0,80	0,80	1,00	1,00

CODE: GAGRBA

## PETER



Size	SOLD OUT	0,30	0,50	0,75	1,00	1,50	2,00
Ant. Ø	1,20	1,20	1,20	1,20	1,50	1,50	1,50
Stem Ø	0,60	0,60	0,70	0,70	0,80	0,80	0,80

CODE: GAPETA

## FRED



Size	0,20	0,30	0,50	0,75	1,00	1,50	2,00
Ant. Ø	1,20	1,20	1,20	1,20	1,50	1,50	1,50
Stem Ø	0,60	0,60	0,70	0,70	0,80	0,80	0,80

CODE: GAFREA

## GRACE



CODE: GAGR

Size	0,10	0,20	0,30	SOLD OUT	
Stem Ø	1,00	1,00	1,20	1,20	

## CINDY



CODE: GACI

Size	0,10	0,20	0,30	0,50
Stem Ø	1,00	1,00	1,20	1,20



## LIVERPOOL

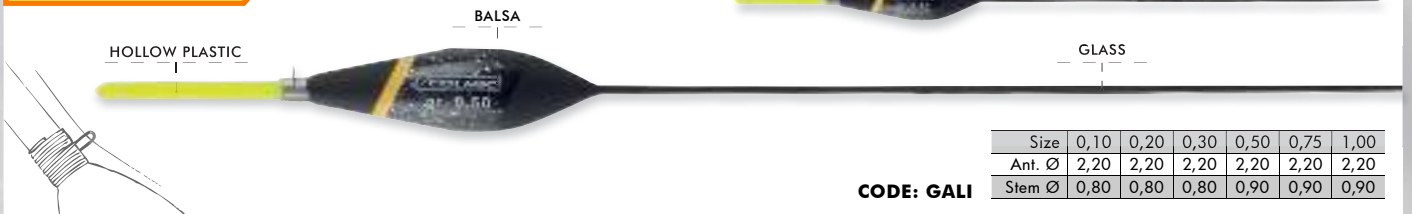

CODE: GALI

Size	0,10	0,20	0,30	0,50	0,75	1,00
Ant. Ø	2,20	2,20	2,20	2,20	2,20	2,20
Stem Ø	0,80	0,80	0,80	0,90	0,90	0,90

## MATRIX

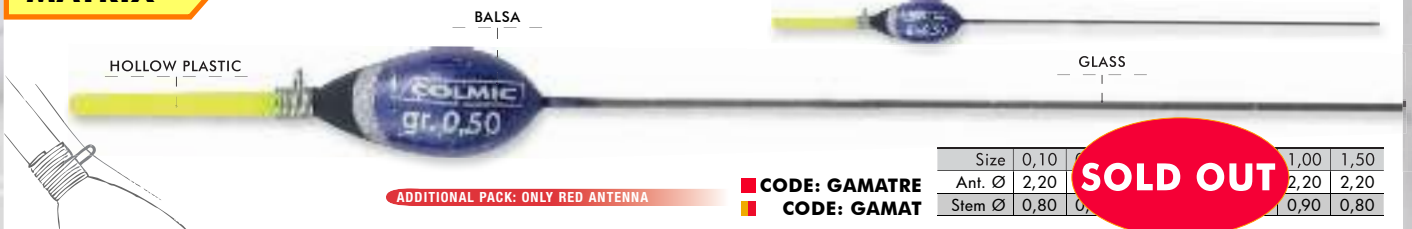

ADDITIONAL PACK: ONLY RED ANTENNA

CODE: GAMATRE  
CODE: GAMAT

**SOLD OUT**

Size	0,10	0,20	0,30	0,50	0,75	1,00	1,50
Ant. Ø	2,20	2,20	2,20	2,20	2,20	2,20	2,20
Stem Ø	0,80	0,80	0,80	0,90	0,90	0,80	0,80

## METAL



CODE: GAMET

Size	0,10	0,20	0,30	0,50	0,75	1,00
Ant. Ø	1,50	1,50	1,50	1,50	1,50	1,50
Stem Ø	0,80	0,80	0,80	0,80	0,80	0,80

# COMPETITION - LAKE

## HIPPOCARP



Size	0,30	0,50	0,75	1,00	1,50
Ant. Ø	2,00	2,00	2,00	2,00	2,00
Stem Ø	1,00	1,00	1,00	1,00	1,00

CODE: GAHIP01

## HIPPOPAST



Size	0,30	0,50	0,75	1,00	1,50
Ant. Ø	2,00	2,00	2,00	2,00	2,00
Stem Ø	1,00	1,00	1,00	1,00	1,00

CODE: GAHIP02

## KERRY



Size	0,10	0,20	0,30	0,50
Ant. Ø	2,60	2,60	2,60	2,60
Stem Ø	1,20	1,20	1,20	1,20

CODE: GAKER

## GARRETH



Size	0,10	0,20	0,30	0,50
Ant. Ø	2,60	2,60	2,60	2,60
Stem Ø	1,20	1,20	1,20	1,20

CODE: GAGAR

## JAMIE



Size	0,10	0,20	0,30	SOLD OUT
Ant. Ø	2,10	2,10	2,10	2,10
Stem Ø	1,00	1,00	1,00	1,00

CODE: GAJAM

## BRIAN PASSANTE

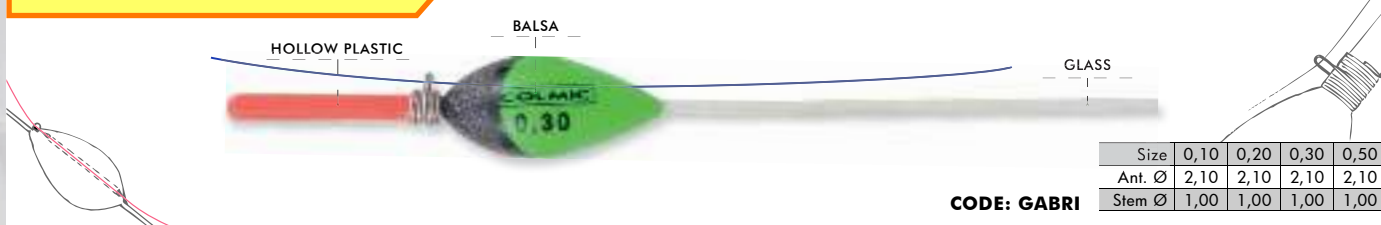

Size	0,10	0,20	0,30	0,50
Ant. Ø	2,10	2,10	2,10	2,10
Stem Ø	1,00	1,00	1,00	1,00

CODE: GABRI

## SPIRAL 1 PASSANTE

Size	0,10	0,20	0,30	0,50	0,75	1,00
Ant. $\varnothing$	1,80	1,80	1,80	1,80	1,80	1,80
Stem $\varnothing$	0,80	0,80	0,80	0,80	0,80	0,80

**CODE: GASPIR01**

## SPIRAL 2 PASSANTE

Size	0,10	0,20	0,30	0,50	0,75	1,00
Ant. $\varnothing$	2,20	2,20	2,20	2,20	2,20	2,20
Stem $\varnothing$	0,80	0,80	0,80	0,80	0,80	0,80

**CODE: GASPIR02**

## SPIRAL 3 PASSANTE

Size	0,10	0,20	0,30	0,50	0,75	1,00
Ant. $\varnothing$	2,20	2,20	2,20	2,20	2,20	2,20
Stem $\varnothing$	0,80	0,80	0,80	0,80	0,80	0,80

**CODE: GASPIR03**

# BLINDO MATERIAL

Blindo Rohacell51 è il materiale innovativo a cellule chiuse con cui vengono costruiti i modelli più innovativi. Questo materiale indistruttibile non prende acqua ed ha un peso specifico del 30% inferiore alla balza, significa che lo stesso galleggiante a pari portata con il materiale Blindo sarà di dimensioni ridotte del 20% e quindi con maggiore sensibilità.

*Blindo Rohacell51 is an innovative material with closed cells used to build innovative models. This indestructible material is water resistant and has a specific 30% less weight than the flounce, meaning that the same capacity float in the Blindo material will have a 20% reduced dimension, thus greater sensitivity.*

## MACISTE

Size	0,10	0,20	0,30	0,50	0,75	1,00
Ant. $\varnothing$	2,00	2,00	2,00	2,00	2,00	2,00
Stem $\varnothing$	0,90	0,90	0,90	0,90	0,90	0,90

**CODE: GAMAC**

**SOLD OUT**

## GOLIA

Size	0,10	0,20	0,30	0,50	0,75	1,00
Ant. $\varnothing$	2,00	2,00	2,00	2,00	2,00	2,00
Stem $\varnothing$	0,90	0,90	0,90	0,90	0,90	0,90

**CODE: GAGOL**

**SOLD OUT**



# COMPETITION - LAKE

## DJANGO

Labels: HOLLOW PLASTIC, BALSА, GLASS

CODE: GADJ

Size	0,10	0,20	0,30	0,50	0,75	1,00
Ant. Ø	1,80	1,80	1,80	1,80	1,80	1,80
Stem Ø	0,80	0,80	0,80	0,80	0,80	0,80

## QUENTIN

Labels: HOLLOW PLASTIC, BALSА, GLASS

CODE: GAQU

Size	0,10	0,20	0,30	0,50	0,75	1,00
Ant. Ø	1,80	1,80	1,80	1,80	1,80	1,80
Stem Ø	0,80	0,80	0,80	0,80	0,80	0,80

## DURANGO 1

Labels: PLASTIC, BALSА, GLASS

CODE: GADUR1

Size	0,10	0,20	0,30	0,50	0,75	1,00
Ant. Ø	2,20	2,20	2,20	2,20	2,20	2,20
Stem Ø	0,80	0,80	0,80	0,90	0,90	0,90

## DURANGO 2

Labels: PLASTIC, BALSА, GLASS

ADDITIONAL PACK: ONLY RED ANTENNA

CODE: GADUR2

Size	0,10	0,20	0,30	0,50	0,75	1,00
Ant. Ø	2,20	2,20	2,20	2,20	2,20	2,20
Stem Ø	0,80	0,80	0,80	0,90	0,90	0,90

## DURANGO 3

Labels: PLASTIC, BALSА, GLASS

ADDITIONAL PACK: ONLY RED ANTENNA

CODE: GADUR3

Size	0,10	0,20	0,30	0,50	0,75	1,00
Ant. Ø	2,20	2,20	2,20	2,20	2,20	2,20
Stem Ø	0,80	0,80	0,80	0,90	0,90	0,90

## DURANGO 4

Labels: PLASTIC, BALSА, GLASS

ADDITIONAL PACK: ONLY RED ANTENNA

CODE: GADUR4

Size	0,10	0,20	0,30	0,50	0,75	1,00
Ant. Ø	2,20	2,20	2,20	2,20	2,20	2,20
Stem Ø	0,80	0,80	0,80	0,90	0,90	0,90

## CARPA



ADDITIONAL PACK: ONLY RED ANTENNA

■ **CODE: GACARRE**  
■ **CODE: GACAR**

Size	0,10	0,20	0,30	0,50	0,75	1,00
Ant. Ø	2,20	2,20	2,20	2,20	2,20	2,20
Stem Ø	0,80	0,80	0,80	0,80	1,00	1,00

## RAMBO



ADDITIONAL PACK: ONLY RED ANTENNA

■ **CODE: GASOLD OUT**  
■ **CODE: GARAM**

Size	0,10	0,20	0,30	SOLD OUT	SOLD OUT	SOLD OUT	1,50
Ant. Ø	3,00	3,00	3,00	3,00	3,00	3,00	3,00
Stem Ø	0,80	0,80	0,80	1,00	1,00	1,00	1,00

## KIMBO



ADDITIONAL PACK: ONLY RED ANTENNA

■ **CODE: GASOLD OUT**  
■ **CODE: GAKIM**

Size	0,10	0,20	0,30	0,50	0,75	1,00	1,50
Ant. Ø	2,20	2,20	2,20	2,20	2,20	2,20	2,20
Stem Ø	0,60	0,60	0,60	0,60	0,60	0,60	0,60

## LIKE



**CODE: GALIK**

Size	0,10	0,20	0,30	0,50	0,75	1,00	1,50
Ant. Ø	3,00	3,00	3,00	3,00	3,00	3,00	3,00
Stem Ø	1,00	1,00	1,00	1,00	1,20	1,20	1,20

## LAROS



Plastic antenna holder

**CODE: GALAR**

Size	0,20	0,30	0,50	0,75	1,00	1,50
Ant. Ø	2,20	2,20	2,20	2,20	2,20	2,20
Stem Ø	0,80	0,80	0,80	0,80	0,80	0,80

## STING



Plastic antenna holder

**CODE: GASTI**

Size	0,20	0,30	0,50	0,75	1,00	1,50
Ant. Ø	2,20	2,20	2,20	2,20	2,20	2,20
Stem Ø	0,80	0,80	0,80	0,80	0,80	0,80

# COMPETITION - LAKE



## SAX

PLASTIC BALSIA CARBON

Size	0,20	0,30	0,50	0,75	1,00	1,50
Ant. Ø	2,20	2,20	2,20	2,20	2,20	2,20
Stem Ø	0,80	0,80	0,80	0,80	0,80	0,80

CODE: GASAX

## MOBY

PLASTIC BALSIA STEEL

ADDITIONAL PACK: ONLY RED ANTENNA

	0,20	0,30
	3,00	3,00
	1,00	1,00

CODE: GAI **SOLD OUT**  
CODE: GA

## SHARK

PLASTIC BALSIA FIBERGLASS

Size	0,10	0,20	0,30	0,50	0,75	1,00	1,50
Ant. Ø	3,00	3,00	3,00	3,00	3,00	3,00	3,00
Stem Ø	0,80	0,80	1,00	1,00	1,00	1,00	1,00

CODE: GASHAA

## STELLA

PLASTIC BALSIA FIBERGLASS

Size	0,10	1,00	1,50
Ant. Ø	3,00	3,00	3,00
Stem Ø	0,80	1,00	1,00

CODE: GASTL **SOLD OUT**

## SIRIA

PLASTIC BALSIA FIBERGLASS

Size	0,10	0,20	0,30	0,50	0,75	1,00	1,50
Ant. Ø	3,00	3,00	3,00	3,00	3,00	3,00	3,00
Stem Ø	0,80	0,80	1,00	1,00	1,00	1,00	1,00

CODE: GASIRA



## GHIGO PASSANTE

**ADDITIONAL PACK: ONLY RED ANTENNA**

**CODE: GAGHIRE**  
**CODE: GAGHI**

Size	0,10	0,20	0,30	0,50	0,75	1,00
Ant. Ø	2,20	2,20	2,20	2,20	2,20	2,20
Stem Ø	0,80	0,80	0,80	0,80	0,80	1,00

## SAURO PASSANTE

**CODE: GASAU**

Size	0,10	0,20	0,30	0,50	0,75	1,00
Ant. Ø	3,00	3,00	3,00	3,00	3,00	3,00
Stem Ø	0,80	0,80	1,00	1,00	1,00	1,00

## PEGASO PASSANTE

**CODE: GAPEGA**

Size	0,10	0,20	0,30	0,50	0,75	1,00	1,50	2,00	3,00	4,00
Ant. Ø	3,00	3,00	3,00	3,00	3,00	3,00	3,00	3,00	3,00	3,00
Stem Ø	0,80	0,80	1,00	1,00	1,00	1,00	1,20	1,20	1,20	1,20

## VETRICE PASSANTE

**CODE: GAVEVA**

Size	0,10	0,20	0,30	0,50	0,75	1,00
Ant. Ø	3,00	3,00	3,00	3,00	3,00	3,00
Stem Ø	1,00	1,00	1,20	1,20	1,20	1,20

# FAST WATERS



## SPOILER

CODE: GASPO

Size	Ant. Glass	Ant. Plastic	Ø Stem
2,00	1,00	1,80	0,80
3,00	1,00	1,80	0,80
4,00	1,00	1,80	0,80
5,00	1,00	2,10	0,90
6,00	1,20	2,10	0,90
8,00	1,20	2,10	0,90
10,00	1,20	2,10	0,90
12,00	1,20	2,10	0,90
15,00	1,50	2,50	0,90
20,00	1,50	2,50	1,20
25,00	1,50	2,50	1,20
30,00	1,50	2,50	1,20
40,00	1,50	2,50	1,20
50,00	1,50	2,50	1,20

## NAVY

CODE: GANAZ

Size	Ant.	Ø Stem	Size	Ant.	Ø Stem
4x14	1,00	0,60	20,00	2,00	1,20
4x16	1,00	0,60	25,00	2,00	1,20
4x18	1,00	0,60	30,00	2,00	1,20
1,00	1,00	0,60			
1,50	1,20	0,70			
2,00	1,20	0,70			
3,00	1,50	0,70			
4,00	1,70	0,80			
5,00	1,70	0,80			
6,00	1,70	0,80			
8,00	1,70	0,90			
10,00	2,00	0,90			
12,00	2,00	1,00			
15,00	2,00	1,00			

## SPINNAKER

CODE: GASPI

Size	Ant.	Ø Stem	Size	Ant.	Ø Stem
0,30	1,00	0,60	15,00	1,80	0,90
0,50	1,00	0,60	20,00	1,80	1,00
0,75	1,00	0,60	25,00	1,80	1,00
1,00	1,20	0,70	30,00	1,80	1,00
1,50	1,20	0,70	40,00	2,00	1,20
2,00	1,20	0,70	50,00	2,00	1,20
2,50	1,20	0,70	60,00	2,00	1,20
3,00	1,20	0,70	80,00	2,00	1,20
4,00	1,50	0,80			
5,00	1,50	0,80			
6,00	1,50	0,80			
8,00	1,80	0,80			
10,00	1,80	0,80			
12,00	1,80	0,90			

## COVATO

Diagram of the COVATO fishing float. It features a red fiberglass stem, a dark balsa body with 'COLMIC gr. 2' printed on it, and a steel hook. A smaller version of the float is shown above.

Size	4x12	4x14	4x16	4x18	1,00	1,25	1,50	2,00	2,50	3,00
Ant. Ø	0,90	0,90	0,90	0,90	1,00	1,00	1,00	1,00	1,20	1,20
Stem Ø	0,50	0,50	0,50	0,50	0,60	0,60	0,60	0,60	0,70	0,70

**CODE: GACOV**

## ABI

Diagram of the ABI fishing float. It features a red fiberglass stem, a dark balsa body with 'COLMIC gr. 1' printed on it, and a steel hook. A smaller version of the float is shown above.

Size	4x12	4x14	4x16	4x18	4x20	1,25	1,50	2,00
Ant. Ø	0,70	0,70	0,70	0,70	0,70	0,80	0,80	0,80
Stem Ø	0,50	0,50	0,50	0,50	0,50	0,50	0,50	0,60

**CODE: GAABI**

## TRENT

Diagram of the TRENT fishing float. It features a yellow fiberglass stem, a dark balsa body with 'COLMIC gr. 3' printed on it, and a steel hook. A smaller version of the float is shown above.

Size	4x14	4x16	4x18	1,00	1,50	2,00	2,50	3,00	4,00	5,00	6,00	8,00
Ant. Ø	0,70	0,70	0,80	0,80	0,80	0,80	0,90	0,90	1,00	1,00	1,00	1,20
Stem Ø	0,50	0,50	0,50	0,50	0,60	0,60	0,70	0,70	0,70	0,70	0,80	0,80

**CODE: GATRE**

## ROVEZZANO

Diagram of the ROVEZZANO fishing float. It features a red fiberglass stem, a light-colored balsa body with 'COLMIC gr. 4' printed on it, and a carbon hook. A smaller version of the float is shown above.

Size	4x10	4x12	4x14	4x16	4x18	1,00	1,50	2,00	2,50	3,00
Ant. Ø	0,80	0,80	0,80	0,80	0,90	0,90	1,00	1,00	1,00	1,20
Stem Ø	0,60	0,60	0,60	0,60	0,60	0,70	0,70	0,70	0,80	0,80

**CODE: GAROV**

# COMPETITION

## LUXOR



Size	4x12	4x14	4x16	4x18	1,00	1,25	1,50	2,00	2,50
Ant. Ø	0,70	0,70	0,70	0,70	0,80	0,80	0,80	0,80	0,80
Stem Ø	0,60	0,60	0,60	0,60	0,70	0,70	0,70	0,70	0,70

CODE: GALUY

## WIND



Size	0,50	0,75	1,00	1,25	1,50	2,00	2,50	3,00
Ant. Ø	0,80	0,80	0,80	0,80	0,80	0,80	0,80	0,80
Stem Ø	0,70	0,70	0,70	0,80	0,80	0,80	0,80	0,80

CODE: GAWIN

## ZAR



Size	4x12	4x14	4x16	4x18	1,00	1,25	1,50	2,00	2,50	3,00	4,00
Ant. Ø	0,70	0,70	0,70	0,70	0,70	0,80	0,80	0,80	0,80	0,80	1,00
Stem Ø	0,60	0,60	0,60	0,70	0,70	0,80	0,80	0,80	0,80	0,80	1,00

CODE: GAZAR



## JOLLY



ADDITIONAL PACK: ONLY RED ANTENNA

■ **CODE: G<sup>GOLD</sup> OUTRE**  
 ■ **CODE: GAJOL**

Size	4X8	4X10	4X12	4x14	4x16	4x18	4X20	1,25	1,50	2,00	2,50	3,00	4,00	5,00	6,00	8,00
Ant. Ø	0,80	0,80	0,80	0,80	0,80	1,00	1,00	1,00	1,20	1,20	1,20	1,20	1,50	1,50	1,80	1,80
Stem Ø	0,60	0,60	0,60	0,60	0,60	0,60	0,70	0,70	0,70	0,70	0,80	0,80	0,90	0,90	1,00	1,20

## MENTA

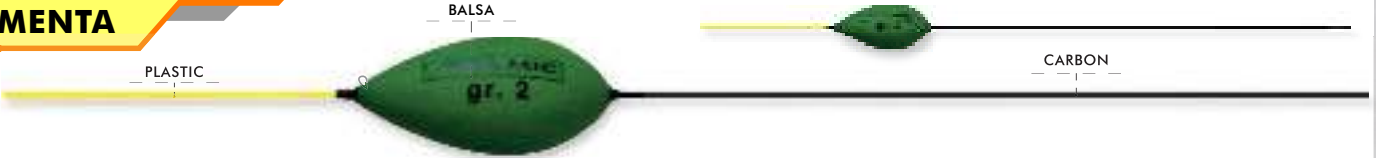

ADDITIONAL PACK: ONLY RED ANTENNA

■ **CODE: G<sup>GOLD</sup> OUTRE**  
 ■ **CODE: GAMEN**

Size	4X10	4X12	4x14	4x16	4x18	1,00	1,50	2,00	2,50	3,00	4,00	5,00	6,00	8,00	10,00
Ant. Ø	0,80	0,80	0,80	0,80	1,00	1,00	1,00	1,20	1,20	1,20	1,50	1,50	1,80	1,80	1,80
Stem Ø	0,60	0,60	0,60	0,60	0,60	0,70	0,70	0,70	0,80	0,80	0,90	0,90	1,00	1,20	1,20

## EDY



**CODE: GAEDY**

Size	4X8	4X10	4X12	4x14	0,50	0,75	1,00	1,25	1,50	2,00	2,50	3,00	4,00	5,00	6,00	8,00	10,00
Ant. Ø	1,00	1,00	1,00	1,00	1,00	1,00	1,20	1,20	1,20	1,20	1,20	1,20	1,20	1,20	1,20	1,20	1,20
Stem Ø	0,40	0,40	0,40	0,40	0,50	0,50	0,50	0,50	0,50	0,60	0,60	0,60	0,70	0,70	0,70	0,70	0,70

## CARPINA



**CODE: GACAPA**

Size	4X10	4X12	4x14	4x16	4x18	1,00	1,50	2,00
Ant. Ø	1,00	1,00	1,00	1,00	1,00	1,20	1,20	1,20
Stem Ø	0,60	0,60	0,60	0,60	0,70	0,70	0,70	0,80

## TEVERE



**CODE: GATEV**

Size	4x8	4x10	4x12	4x14	0,50	0,75	1,00	1,50	2,00
Ant. Ø	0,80	0,80	0,80	1,00	1,00	1,00	1,00	1,20	1,20
Stem Ø	0,40	0,40	0,40	0,40	0,50	0,50	0,50	0,60	0,60

## CARRERA



**CODE: GACAS**

Size	4x10	4x12	4x14	4x16	4x18	1,00	1,25	1,50	2,00	2,50	3,00
Ant. Ø	1,00	1,00	1,00	1,00	1,00	1,00	1,20	1,20	1,20	1,20	1,20
Stem Ø	0,50	0,50	0,50	0,50	0,50	0,50	0,60	0,60	0,60	0,60	0,70



# COMPETITION

## ROUBAIX



CODE: GAROU

Size	0,20	0,30	0,50	0,75	1,00	1,25	1,50
Ant. Ø	0,80	0,80	0,80	0,80	1,00	1,00	1,00
Stem Ø	0,50	0,50	0,50	0,50	0,60	0,60	0,60

## TIMON



CODE: GATIM

Size	4x12	4x14	4x16	4x18	1,00	1,25	1,50
Ant. Ø	0,70	0,70	0,70	0,80	0,80	0,80	0,90
Stem Ø	0,50	0,50	0,50	0,60	0,60	0,60	0,60

## LUX



ADDITIONAL PACK: ONLY RED ANTENNA

CODE: SOLD OUT XRE  
CODE: GALUX

Size	0,20	0,30	0,50	0,75	1,00	1,25	1,50
Ant. Ø	0,80	0,80	1,00	1,00	1,00	1,00	1,00
Stem Ø	0,60	0,60	0,60	0,60	0,60	0,60	0,60

## SPINADESCO



CODE: GASPI

Size	4x12	4x14	4x16	4x18	1,00	1,25	1,50
Ant. Ø	0,50	0,50	0,50	0,60	0,60	0,60	0,60
Stem Ø	0,40	0,40	0,40	0,50	0,50	0,50	0,50

## CAVECCHIA



CODE: GACAV

Size	4x12	4x14	4x16	4x18	1,00	1,25	1,50	2,00
Ant. Ø	0,50	0,50	0,50	0,50	0,60	0,60	0,60	0,60
Stem Ø	0,50	0,50	0,50	0,50	0,50	0,50	0,50	0,50

## VELOX



CODE: GAVEM

Size	4x8	4x10	4x12	4x14	4x16	4x18
Ant. Ø	0,70	0,70	0,70	0,70	0,80	0,80
Stem Ø	0,40	0,40	0,40	0,40	0,50	0,50

## BORMIDA

**CODE: GABOR**

Size	4x10	4x12	4x14	4x16	4x18	1,00	1,25	1,50
Ant. Ø	0,60	0,60	0,60	0,60	0,60	0,80	0,80	0,80
Stem Ø	0,50	0,50	0,50	0,50	0,50	0,50	0,50	0,50

## MONDINE

**CODE: GAMON02**

Si:	0,20	0,30	0,50	0,70	1,00	1,50
Ant. Ø	1,20	1,20	1,20	1,20	1,20	1,20
Stem Ø	0,70	0,70	0,70	0,70	0,70	0,70

## RUNNY

**CODE: GARUN**

Size	0,20	0,30	SOLD OUT	SOLD OUT	SOLD OUT	SOLD OUT
Ant. Ø	0,80	0,80	0,80	0,80	1,00	1,00
Stem Ø	0,50	0,50	0,50	0,50	0,50	0,50

## ALBORELLA

**CODE: GAALB**

Size	4x8	4x10	4x12	4x14	4x16	4x18	4x20	5x20	6x20
Ant. Ø	0,60	0,60	0,60	0,60	0,60	0,80	0,80	0,80	0,80
Stem Ø	0,40	0,40	0,40	0,50	0,50	0,50	0,50	0,50	0,50

## TESSE

**CODE: GATES**

Size	4x14	4x16	4x18	1,00	1,25	1,50	2,00	3,00
Ant. Ø	0,60	0,60	0,80	0,80	0,80	0,80	1,00	1,00
Stem Ø	0,40	0,40	0,40	0,40	0,40	0,40	0,50	0,50

## SENNÀ

**CODE: GASEN**

Size	4x8	4x10	4x12	4x14	4x16	4x18	1,00
Ant. Ø	0,60	0,60	0,60	0,80	0,80	0,80	0,80
Stem Ø	0,40	0,40	0,40	0,40	0,40	0,50	0,50

# SPECIAL BOLO

## ROXY



CODE: GAROX

Size	4,00	6,00	8,00	10,00	15,00
Ant. Ø	2,00	2,00	2,50	2,50	3,50
Stem Ø	1,00	1,00	1,00	1,00	1,20

## CIGNO



CODE: GACIG

Size	4,00	6,00	8,00	10,00	12,00	15,00	20,00
Ant. Ø	3,00	3,00	3,50	3,50	3,50	4,00	4,50
Stem Ø	1,20	1,20	1,50	1,50	1,50	1,50	1,80

## SILE PASSANTE

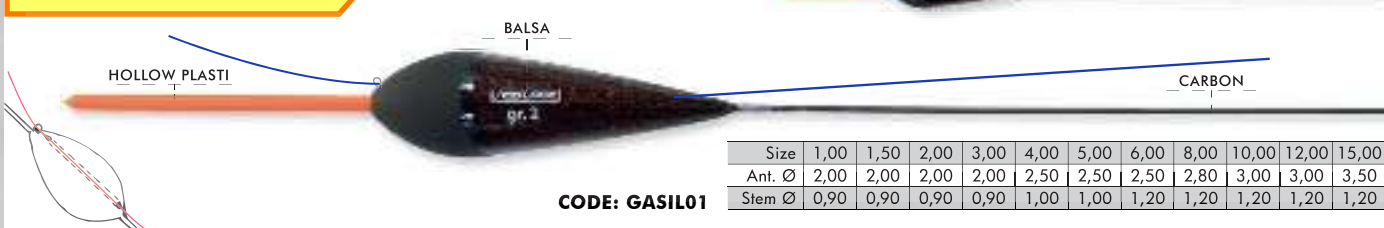

CODE: GASIL01

Size	1,00	1,50	2,00	3,00	4,00	5,00	6,00	8,00	10,00	12,00	15,00
Ant. Ø	2,00	2,00	2,00	2,00	2,50	2,50	2,50	2,80	3,00	3,00	3,50
Stem Ø	0,90	0,90	0,90	0,90	1,00	1,00	1,20	1,20	1,20	1,20	1,20

## MINCIO PASSANTE

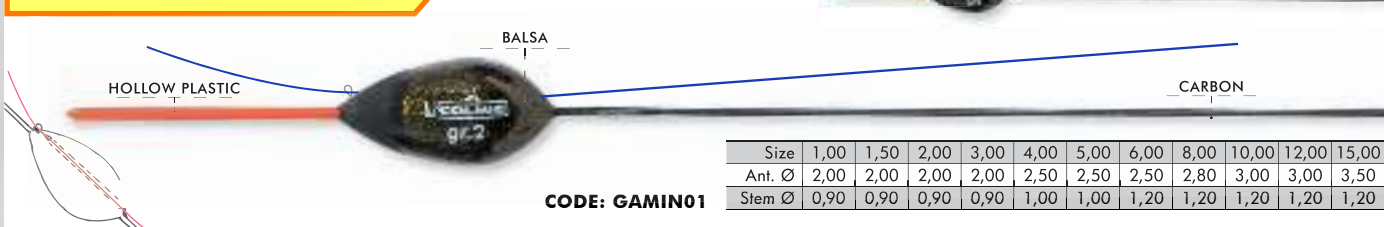

CODE: GAMIN01

Size	1,00	1,50	2,00	3,00	4,00	5,00	6,00	8,00	10,00	12,00	15,00
Ant. Ø	2,00	2,00	2,00	2,00	2,50	2,50	2,50	2,80	3,00	3,00	3,50
Stem Ø	0,90	0,90	0,90	0,90	1,00	1,00	1,20	1,20	1,20	1,20	1,20

## BIG



CODE: GABIG

Size	0,30	0,50	0,75	1,00	1,50	2,00	2,50	3,00	4,00	5,00	6,00	8,00
Ant. Ø	1,50	1,50	1,50	1,50	1,80	2,00	2,00	2,50	2,50	2,50	3,00	3,00
Stem Ø	0,80	0,80	0,80	1,00	1,00	1,00	1,20	1,20	1,35	1,35	1,35	1,35

## SAM



CODE: GASAM

Size	0,30	0,50	0,75	1,00	1,50	2,00	2,50	3,00
Ant. Ø	1,50	1,50	1,50	1,50	1,80	2,00	2,00	2,50
Stem Ø	0,80	1,00	1,00	1,00	1,00	1,20	1,20	1,20

## MULTI BARB



CODE: GAMUBA

Size	1,00	1,50	2,00	3,00	4,00	5,00
Ant. Ø	3,00	3,00	3,00	3,00	3,00	3,00
Stem Ø	1,20	1,20	1,20	1,20	1,50	1,50

## MULTI CARP



CODE: GAMUCA

Size	1,00	1,50	2,00	3,00	4,00	5,00
Ant. Ø	3,00	3,00	3,00	3,00	3,00	3,00
Stem Ø	1,20	1,20	1,20	1,20	1,50	1,50

## MULTI BREAM



CODE: GAMUBR

Size	1,00	1,50	2,00	3,00	4,00	5,00
Ant. Ø	2,00	2,50	2,50	2,50	2,50	2,50
Stem Ø	1,00	1,00	1,20	1,20	1,20	1,50

## MULTI MULET



CODE: GAMUMU

Size	1,00	1,50	SOLD OUT	SOLD OUT	SOLD OUT	SOLD OUT
Ant. Ø	3,00	3,00	3,00	3,00	3,00	3,00
Stem Ø	1,20	1,20	1,20	1,20	1,30	1,30



# MULTICOLOR

## JUAN



CODE: GAJUA

Size	1,00	1,50	2,00	3,00	4,00	6,00	8,00	10,00
Ant. Ø	3,00	3,00	3,00	3,00	3,00	3,00	3,00	3,00
Stem Ø	1,20	1,20	1,20	1,20	1,20	1,50	1,50	1,50

## PLOVDIV



CODE: GAPLO

Size	1,00	1,50	2,00	3,00	4,00	5,00
Ant. Ø	1,50	1,50	1,50	1,50	1,50	1,50
Stem Ø	0,80	0,80	0,80	0,80	0,80	0,80

## VALENCE



CODE: GAVALA

Size	1,00	1,50	2,00	3,00	4,00	5,00
Ant. Ø	2,10	2,10	2,10	2,10	2,10	2,10
Stem Ø	1,20	1,20	1,20	1,20	1,50	1,50





# SPECIAL TROUT

## MONACO

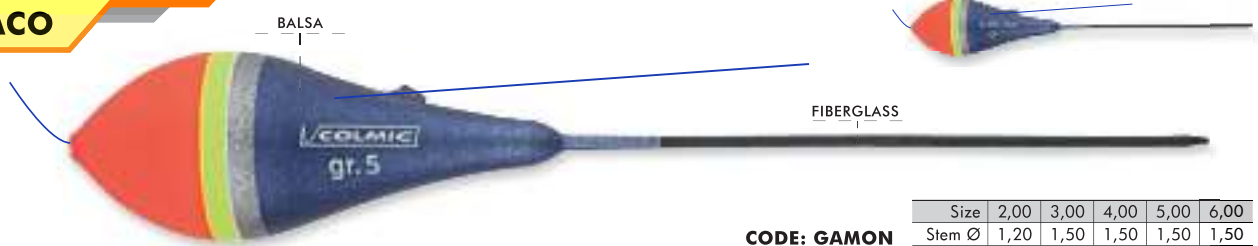

CODE: GAMON

Size	2,00	3,00	4,00	5,00	6,00
Stem Ø	1,20	1,50	1,50	1,50	1,50

## BERLINO



CODE: GABER

Size	2,00	3,00	4,00	5,00	6,00
Stem Ø	1,50	1,50	1,50	1,50	1,50

## COLONIA PASSANTE

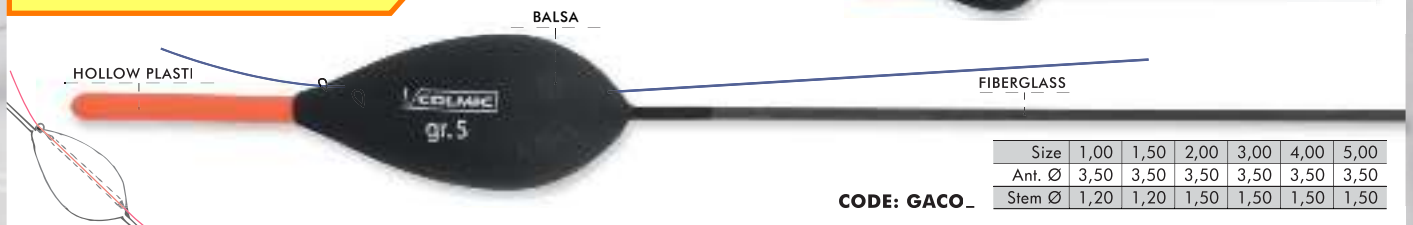

CODE: GACO

Size	1,00	1,50	2,00	3,00	4,00	5,00
Ant. Ø	3,50	3,50	3,50	3,50	3,50	3,50
Stem Ø	1,20	1,20	1,50	1,50	1,50	1,50

## PENNA TROTA

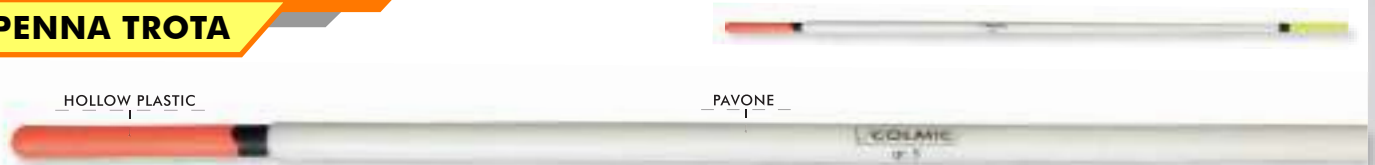

CODE: GAPEN

Size	2,00	3,00	4,00	5,00	6,00	8,00
Stem Ø	4,50	4,50	4,50	4,50	4,50	4,50

# BOMBARDE HAND MADE

Grazie al Poliuretano di ultima generazione, utilizzato anche nell'industria aeronautica, e al laborioso processo di lavorazione manuale, le bombarde Colmic hanno:

- Dimensioni contenute e tutte uguali rispetto alle comuni bombarde in balsa.
- Una perfetta bilanciatura che garantisce in qualsiasi situazione un recupero orizzontale.

*Thanks to an ultimate polyurethane used also in the aerospace industry and thanks to the laborious handcrafting, Colmic bombs feature:*

- *Small and all equal sizes than the commons raft's bombarde.*
- *A perfect balance which guarantees an horizontal recovery in any situation.*



1  
Tornitura della forma.  
Turning form.



2  
Taglio e tornitura del foro.  
Hole cutting and turning.



3  
Inserimento del peso in ottone.  
Inserting the weight brass.



4  
Saldatura con colla e levigatura della superficie.  
Glue welded and polished surface.



5  
Inserimento del tubetto in plastica.  
Plastic tube insertion.



6  
Verniciatura ed inserimento dell'anima in fibra protettiva.  
Painting and insertion of the protective fiber.



## BOMBARDE HAND MADE

	CAL.	code	SIZES (gr.)									
a	0	BMST00	6,00	8,00	10,00	12,00	15,00	20,00	25,00	30,00	35,00	40,00
b	0,20	BMST01	6,00	8,00	10,00	12,00	15,00	20,00	25,00	30,00	35,00	40,00
c	0,50	BMST02	6,00	8,00	10,00	12,00	15,00	20,00	25,00	30,00	35,00	40,00
d	1,00	BMST03	6,00	8,00	10,00	12,00	15,00	20,00	25,00	30,00	35,00	40,00
e	1,50	BMST04	6,00	8,00	10,00	12,00	15,00	20,00	25,00	30,00	35,00	40,00
f	2,00	BMST05	6,00	8,00	10,00	12,00	15,00	20,00	25,00	30,00	35,00	40,00
g	3,00	BMST06	6,00	8,00	10,00	12,00	15,00	20,00	25,00	30,00	35,00	40,00

	CAL.	code	SIZES (gr.)			
h	2	BMST608	2,00			
h	3	BMST610	10,00			
h	4	BMST613	13,00			
h	5	BMST6..	16,00	19,00		
h	6	BMST6..	22,00	26,00	30,00	35,00



**MAGRA PASSANTE**

Size	0,30	0,50	0,75	1,00	1,50	2,00	3,00
Ant. Ø	3,00	3,00	3,00	3,00	3,00	3,00	3,00
Stem Ø	0,80	0,80	0,80	0,80	0,90	0,90	1,00

**CODE: GAMAG05**

**ONDA PASSANTE**

Size	0,30	0,50	0,75	1,00	1,50	2,00	3,00
Ant. Ø	3,00	3,00	3,00	3,00	3,00	3,00	3,00
Stem Ø	0,80	0,80	0,80	0,80	0,90	0,90	1,00

**CODE: GAOND01**

**MARATEA STARLITE**

Size	0,50	0,75	1,00	1,50	2,00	3,00	4,00	5,00	6,00	8,00
Ant. Ø	3,00	3,00	3,00	3,00	4,50	4,50	4,50	4,50	4,50	4,50
Stem Ø	1,00	1,00	1,20	1,50	1,50	1,50	1,50	1,50	1,50	1,50

**CODE: GAMAR01**

**RAVENNA STARLITE**

Size	0,50	0,75	1,00	1,50	2,00	3,00	4,00	5,00	6,00	8,00
Ant. Ø	3,00	3,00	3,00	3,00	4,50	4,50	4,50	4,50	4,50	4,50
Stem Ø	1,00	1,00	1,20	1,20	1,20	1,50	1,50	1,50	1,50	1,50

**CODE: GARAV01**

**PALERMO**

Size	1,00	1,50	2,00	3,00	4,00	5,00	6,00
Ant. Ø	4,50	4,50	4,50	4,50	4,50	4,50	4,50
Stem Ø	1,20	1,20	1,20	1,50	1,50	1,50	1,50

**CODE: GAPAL**



# SPECIAL SEA

## BARI



CODE: GABAR

Size	1,00	1,50	2,00	3,00	4,00	5,00	6,00
Ant. Ø	4,50	4,50	4,50	4,50	4,50	4,50	4,50
Stem Ø	1,20	1,20	1,20	1,50	1,50	1,50	1,50

## VENEZIA



CODE: GAVEN

Size	1,00	1,50	2,00	3,00	4,00	5,00	6,00
Ant. Ø	4,50	4,50	4,50	4,50	4,50	4,50	4,50
Stem Ø	1,20	1,20	1,20	1,50	1,50	1,50	1,50

## NAPOLI



CODE: GANAP

Size	0,50	0,75	1,00	1,50	2,00	3,00
Ant. Ø	3,00	3,00	3,00	3,00	3,00	3,00
Stem Ø	1,00	1,00	1,20	1,20	1,20	1,20

## TROPEA



CODE: GATROP

Size	0,30	0,50	0,75	1,00	1,50	2,00	3,00
Ant. Ø	3,00	3,00	3,00	3,00	3,00	3,00	3,00
Stem Ø	1,00	1,00	1,00	1,20	1,20	1,20	1,20

## SARAGO



CODE: GASAR

Size	0,20	0,30	0,50	0,75	1,00	1,50	2,00	3,00	4,00
Ant. Ø	3,00	3,00	3,00	3,00	3,00	3,00	3,00	3,00	3,00
Stem Ø	1,00	1,00	1,00	1,00	1,20	1,20	1,35	1,35	1,35

## ZIP



CODE: GAZIP

Size	0,50	0,75	1,00	1,50	2,00	3,00	4,00
Ant. Ø	3,00	3,00	3,00	3,00	3,00	3,00	3,00
Stem Ø	1,00	1,00	1,20	1,20	1,35	1,35	1,50

## COOPER



ADDITIONAL PACK: ONLY RED ANTENNA



CODE: GACOORE  
CODE: GACOO

Size	0,30	0,50	0,75	1,00	1,50	2,00	3,00	4,00	5,00	6,00	8,00	10,00	12,00	15,00	20,00
Ant. Ø	3,00	3,00	3,00	3,00	3,00	3,00	3,00	3,00	4,50	4,50	4,50	4,50	4,50	4,50	4,50
Stem Ø	1,00	1,00	1,00	1,20	1,20	1,35	1,35	1,50	1,50	1,50	1,50	1,50	1,75	1,75	1,75

## TRIGLIA



CODE: GATRIA

Size	1,00	1,50	2,00	3,00	4,00	5,00	6,00	8,00
Ant. Ø	4,50	4,50	4,50	4,50	4,50	4,50	4,50	4,50
Stem Ø	1,35	1,35	1,35	1,50	1,50	1,50	1,50	1,50

## BOGA



CODE: GABOG

Size	1,00	1,50	2,00	3,00	4,00	5,00	6,00	8,00	10,00
Ant. Ø	4,50	4,50	4,50	4,50	4,50	4,50	4,50	4,50	4,50
Stem Ø	1,20	1,20	1,35	1,35	1,50	1,50	1,50	1,50	1,50



## AGUGLIA STARLITE



PU  
POLIURETANO  
HIGH SPECIFIC WEIGHT

CODE: GAAGG

Size	2,00	3,00	4,00	6,00	8,00	10,00	15,00	20,00
Ant. Ø	4,50	4,50	4,50	4,50	4,50	4,50	4,50	4,50

## SCHIUMA



PU  
POLIURETANO  
HIGH SPECIFIC WEIGHT

CODE: GASCH

code	A	B	C	D	E	F	G	H
Size	2,00	3,00	4,00	6,00	8,00	10,00	15,00	20,00

# SCORREVOLI

## COOPER SCORREVOLE



Size	4,00	6,00	8,00	10,00	12,00	15,00	20,00	25,00	30,00
Ant. Ø	4,50	4,50	4,50	4,50	4,50	4,50	4,50	4,50	4,50
Stem Ø	1,50	1,50	1,75	1,75	1,75	1,75	1,75	1,75	1,75

CODE: GB COO

## LEO SCORREVOLE



Size	1,00	1,50	2,00	3,00	4,00	5,00	6,00
Ant. Ø	4,50	4,50	4,50	4,50	4,50	4,50	4,50
Stem Ø	1,20	1,20	1,20	1,20	1,50	1,50	1,50

CODE: GB LEO

## BOGA SCORREVOLE

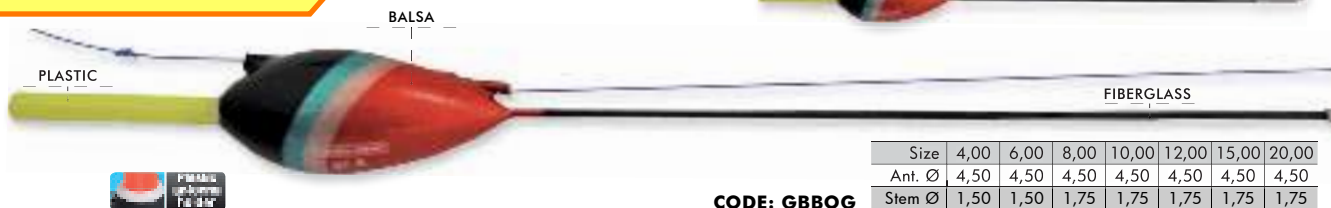

Size	4,00	6,00	8,00	10,00	12,00	15,00	20,00
Ant. Ø	4,50	4,50	4,50	4,50	4,50	4,50	4,50
Stem Ø	1,50	1,50	1,75	1,75	1,75	1,75	1,75

CODE: GB BOG

## MENTA SCORREVOLE



Size	4,00	6,00	8,00	10,00	12,00	15,00	20,00	30,00
Ant. Ø	4,00	4,00	4,00	4,00	4,00	4,00	4,00	4,00
Stem Ø	1,50	1,50	1,80	1,80	1,80	1,80	1,80	1,80

CODE: GB MESC

## TIGRO SCORREVOLE

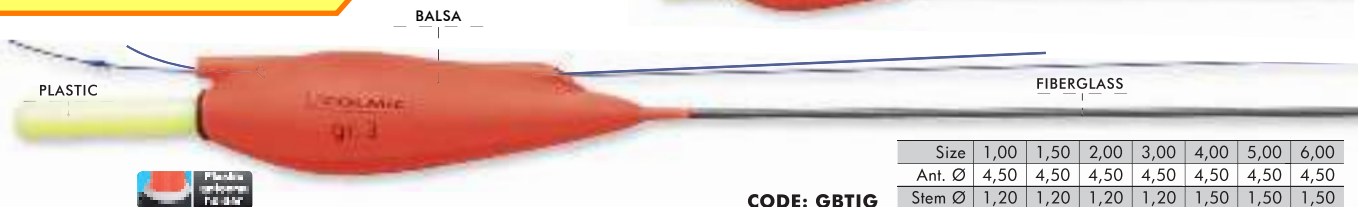

Size	1,00	1,50	2,00	3,00	4,00	5,00	6,00
Ant. Ø	4,50	4,50	4,50	4,50	4,50	4,50	4,50
Stem Ø	1,20	1,20	1,20	1,20	1,50	1,50	1,50

CODE: GB TIG

## MENTA SCORREVOLE STARLITE



Size	4,00	6,00	8,00	10,00	12,00	15,00	20,00
Ant. Ø	4,50	4,50	4,50	4,50	4,50	4,50	4,50
Stem Ø	1,50	1,50	1,80	1,80	1,80	1,80	1,80

CODE: GB MESD



**AERO RIVER**

Size	12,00	14,00	16,00	18,00	20,00
Ant. Ø	3,00	3,00	3,50	3,50	3,50
Fisch. Ø	4,00	4,00	5,00	5,00	5,00

**CODE: GCAERIVO**

**AERO BLINDO 1**

Size	10,00	12,00	14,00	16,00	18,00	20,00	22,00	25,00	30,00
Ant. Ø	3,00	3,00	3,00	3,50	3,50	3,50	4,00	4,00	4,00
Fisch. Ø	4,00	4,00	4,00	5,00	5,00	5,00	6,00	6,00	6,00

**CODE: GCABLI**

**AERO BLINDO SCORREVOLE**

Size	12,00	14,00	16,00	18,00	20,00
Ant. Ø	3,00	3,00	3,00	3,50	3,50
Ant. Ø	4,50	4,50	4,50	5,00	5,00

**CODE: GCABLS**



## AERO BLINDO CANAL

**CODE: GCABC**

Size	6,00	8,00	10,00	12,00	14,00	16,00	18,00	20,00	22,00	25,00
Ant. Ø	3,00	3,00	3,00	3,00	3,00	3,00	3,50	3,50	3,50	3,50
Ant. Ø	4,50	4,50	4,50	4,50	4,50	4,50	5,00	5,00	5,00	5,00

## AERO FRECCIA

**CODE: GCFARF**

Size	12,00	14,00	16,00	18,00	20,00	22,00	25,00	30,00
Fisch. Ø	6,00	6,00	6,00	6,00	6,00	6,00	6,00	6,00

## AERO ELAN

**CODE: GCAEAL**

Size	10,00	12,00	14,00	16,00	18,00	20,00	22,00	25,00	30,00
Ant. Ø	4,50	4,50	4,50	4,50	4,50	5,00	5,00	5,00	5,00

**SINFLEX AMALFI**



**CODE: GCIV07**

Size	4,00	6,00	8,00	10,00	12,00	15,00	20,00
Ant. Ø	4,50	4,50	4,50	4,50	4,50	4,50	4,50

**SINFLEX SALERNO**



**CODE: GCIV08**

Size	4,00	6,00	8,00	10,00
Ant. Ø	4,50	4,50	4,50	4,50

**SINFLEX MISTRAL**



HOLLOW PLASTIC

**CODE: GCIV01**

Size	4+2	6+2	8+2	10+2	12+2
Ant. Ø	5,00	5,00	5,00	5,00	5,00

**SINGLEX IBERIA**



HOLLOW PLASTIC

**CODE: GCIV02**

Size	6,00	8,00	10,00	12,00
Ant. Ø	5,00	5,00	5,00	5,00

**SINFLEX SPAGNA**



HOLLOW PLASTIC

**CODE: GCIV05**

Size	8+4	10+4	12+4	12+6	14+4	14+6	16+4	16+6	16+8	18+8	20+10	25+10
Ant. Ø	5,00	5,00	5,00	5,00	5,00	6,00	6,00	6,00	6,00	6,00	6,00	6,00

**SINFLEX GAROLDA**



SINFLEX

**CODE: GCGARO**

Size	10,00	12,00	14,00	16,00	18,00	20,00	22,00	25,00
Fisch. Ø	4,00	4,00	4,00	4,00	4,80	4,80	4,80	4,80

## SINFLEX OSTELLATO



Size	10,00	12,00	14,00	16,00	18,00	20,00	22,00	25,00
Insert. Ø	3,00	3,00	3,00	3,00	3,00	3,00	3,00	3,00
Stem Ø	6,00	6,00	6,00	6,00	6,00	8,00	8,00	8,00

CODE: GAIV06

## SINFLEX JET



Size	8+1	10+1	12+1	14+1	16+1	18+1	20+1	22+1	25+1
Ant. Ø	5,00	5,00	5,00	5,00	5,00	5,00	5,00	5,00	5,00

CODE: GCIV04

## VICTORY BREAM

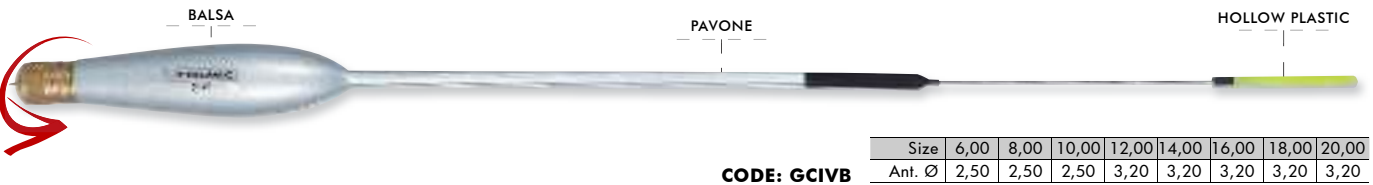

Size	6,00	8,00	10,00	12,00	14,00	16,00	18,00	20,00
Ant. Ø	2,50	2,50	2,50	3,20	3,20	3,20	3,20	3,20

CODE: GCIVB



## STRALE PAVONE PIOMBATO



Size	2+1	3+1	4+1	5+1
Ant. Ø	4,50	4,50	4,50	5,00

CODE: GCISG

## STRALE BREM + INSERTI



Size	2+1	3+1	SOLD OUT	5+1
Ant. Ø	3,00	3,00	3,00	3,00

CODE: GCISB

**VICTORY MULTICOLOR**



CODE: GCIVM

Size	2+2	3+2	4+2	6+2	8+2	10+2
Ant. Ø	3,50	3,50	3,50	3,50	3,50	3,50

**VICTORY NIGHT**



CODE: GCRVA

Size	2+2	3+2	4+2
Ant. Ø	3,00	3,00	3,00

**VICTORY OLBIA**



CODE: GCRVAA

Size	4,00	6,00	8,00	10,00	12,00	15,00	20,00
Ant. Ø	4,50	4,50	4,50	4,50	4,50	4,50	4,50

**VICTORY FORMIA**



CODE: GCIVF

Size	6,00	8,00	10,00	12,00
Ant. Ø	4,50	4,50	4,50	4,50

**SINFLEX BASTIA**



CODE: GCIV09

Size	6,00	8,00	10,00	12,00	15,00
Ant. Ø	4,50	4,50	4,50	4,50	4,50

**STRALE STARLITE**



CODE: GCISS

**SOLD OUT**



## FERMA GALLEGGIANTE CON GIRELLA

FLOAT STOPPER WITH SWIVEL

CODE: FE003 - 5PCS

Questo dispositivo consente di trasformare un galleggiante di struttura classica in un galleggiante di tipo inglese. Inserendo all'interno del tubetto in silicone la deriva di un qualunque galleggiante potremo avvalerci della tecnica english style.

*This accessory allows you to transform a classically shaped float into a waggler-type float. By inserting the stem of any float into the silicone tube you can transform it to English style every time you need to. Very useful in both freshwater and sea angling.*



## TESTE ALLUMINIO

ALUMINIUM HEADS

Queste testine di alluminio, sono state ideate e realizzate per rendere un qualsiasi galleggiante inglese con rondelle, un galleggiante a scorrere che porti sulla lenza grammature sostenute. Infatti togliendo la testa piombata del nostro galleggiante e inserendo questa testina di alluminio, possiamo ottenere le solite caratteristiche di un classico galleggiante inglese nato specificamente per la pesca a scorrere.

*These heads in aluminium have been designed and produced to transform any waggler with rings into a running float that can carry even significant weights on the line. By removing the weighted head of the waggler and replacing it with this aluminium head, you can obtain all the classical features of a waggler designed specifically for English-style fishing.*



Code	pcs
GCZ1	10
GCZ3	12



## ANTENNE VUOTE

HOLLOW ANTENNAS

Antenne vuote ad alta visibilità, molto leggere e robuste. Distribuite in confezioni da 5 pezzi. Colori giallo ed arancio fluorescente.

*High visibility hollow tips, very light and strong. Distributed in packs of 5. Colours. Fluorescent red and yellow.*

Code	Length mm
ANT1247	1,20 47
ANT1555	1,50 55
ANT1855	1,80 55
ANT2055	2,00 55
ANT2560	2,50 60
ANT3065	3,00 65
ANT3565	3,50 65
ANT4065	4,00 65

## RICAMBIO FISCHIONE BREAM

SPARE FISCHIONE BREAM

CODE: ANT5003 - 6PCS

Confezione assortita di un fischione per diametro colore giallo e rosso.

Diam. 4,00 - 4,80 - 6,50.

*Assorted pack including one hollow tip per diameter in red and yellow colour.*

Diam. 4.00 - 4.80 - 6.50mm.



## ANTENNE VUOTE

CODE: ANT5002 - 4PCS

Antenne vuote di ricambio, per galleggianti Inglesi VICTORY e STRALE BREAM. Il massimo come leggerezza e visibilità. Confezioni da 4 pezzi.

Hollow spare tips for VICTORY and STRALE BREAM match floats. The last word in lightness and visibility. 4-piece pack.

## FISCHIONI PER INGLESÌ

WAGGLER HOLLOW TIPS

CODE: ANT5000

(Red/Yellow - 4pcs)

2 pz: Ø 8,0mm

2 pz: Ø 6,0mm

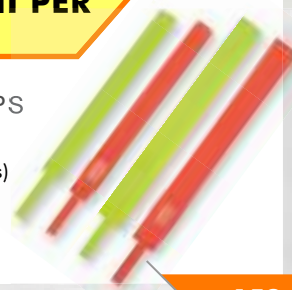

# SOFT SHELL



Il Softshell è un tessuto che ha rivoluzionato l'abbigliamento tecnico per la pesca, poiché è in grado di offrire un confort ed una vestibilità di livello superiore, rispetto ai tessuti tradizionali. Le tecnologie Thermoproof system 3000 e Waterproof system 3000, vi garantiranno sempre calore ed impermeabilità. Cuciture termosaldate, zip waterproof, grandi e capienti tasche interne ed esterne.

*Softshell is a fabric that has revolutionised technical clothing for fishing, since it delivers superior comfort and fit compared with traditional fabrics. The Thermoproof system 3000 and Waterproof system 3000 technologies guarantee constant warmth and waterproofing. Heat-sealed seams, waterproof zips, big, roomy inside and outside pockets.*



## GIACCA SOFTSHELL BLU/GRIGIO

### BLUE/GREY SOFTSHELL JACKET

Questa giacca in materiale SOFT SHELL è stata creata per abbinare confort e protezione dal vento e freddo. Il suo peso contenuto abbinato alla qualità del materiale, fa sì che questo capo si modelli perfettamente al corpo, assecondando con estrema morbidezza i nostri movimenti in fase di pesca. Dotata di 3 tasche con Zip Waterproof e cuciture termosaldate, è l'ideale per le nostre battute di pesca sia in fiume sia in mare.

*This SOFT SHELL style jacket has been developed to protect the fisherman from wind and cold weather, its limited weight and the quality of the materials allow the jacket to perfectly fit the body and allow the maximum freedom of movement during the fishing action. Feature three Zippered Waterproof bags and thermo welded sewing, the perfect choice for both fresh and saltwater outings.*



CODE	Size
ABG005A	S
ABG005B	M
ABG005C	L
ABG005D	XL
ABG005E	2XL
ABG005F	3XL



## GILET SOFTSHELL BLU/GRIGIO

### BLUE/GREY SOFTSHELL WAISTCOAT

Ideale per le mezze stagioni, trova il suo ideale abbinamento ad un Pile o ad una T/Shirt estiva per le nostre uscite di pesca mattutine o serali, dove la temperatura è sicuramente più frizzante. Anche il Gilet SOFT SHELL è dotato di 3 tasche con Zip Waterproof e cuciture termosaldate.

*Perfect item for the mid seasons, match very effectively with a fleece or a t-shirt in the early morning or at night when the temperatures are lower also in the warm season. Also the soft shell vest features 3 waterproof zippered pockets and thermo-welded sewing.*

CODE	Size
ABGL001A	S
ABGL001B	M
ABGL001C	L
ABGL001D	XL
ABGL001E	2XL
ABGL001F	3XL



## SALOPETTE SOFTSHELL BLU/GRIGIO

### BLUE/GREY SOFTSHELL SALOPETTE

Calda ed elegante salopette da competizione in materiale SOFT SHELL. Dotata di 3 tasche con Zip Waterproof e cuciture termosaldate, è ideale nelle fredde e umide giornate invernali dove è indispensabile avere un capo che ci protegga totalmente da freddo e pioggia.

*Warm and elegant SOFT SHELL competition salopette. Features three Zip Waterproof pockets and thermo sewing, ideal for cold and humid winter days on the water when an outwear clothe protecting us from cold and rain is a must.*

CODE	Size
ABP003C	L
ABP003D	XL
ABP003E	2XL
ABP003F	3XL



## PANTALONE SOFTSHELL BLU/GRIGIO

### BLUE/GREY SOFTSHELL TROUSER

Eleganti pantaloni in materiale SOFT SHELL ideali per la pesca e tutte la attività all'aperto. Caldi, eleganti, resistenti all'acqua e dotati di 2 tasche frontali e una tasca posteriore con Zip Waterproof, sono indispensabili nelle nostre giornate invernali di pesca.

*Elegant SOFT SHELL fabric pants, perfect for fishing and outdoor activities. Warm, elegant, waterproof, features two front pockets and one Zippered Waterproof rear pocket, perfect for winter days on the water.*

CODE	Size
ABP004A	S
ABP004B	M
ABP004C	L
ABP004D	XL
ABP004E	2XL
ABP004F	3XL



## GIACCA SOFTSHELL COMFORT

### COMFORT SOFTSHELL JACKET

Giacca antivento e traspirante allo stesso tempo. L'abbinamento di morbidezza e leggerezza, consente a questa giacca di modellarsi e seguire i movimenti del corpo non disperdendo il calore corporeo. La sua vestibilità non impedisce i movimenti durante la pratica sportiva e lo rende un capo moderno adatto all'utilizzo quotidiano.

*Breathable and wind resistant jacket. Thanks to its smoothness and lightness the jacket adapts perfectly to the body shape not disturbing or impeding the body movements without losing the heat generated by the body. Under an aesthetic point of view this garment has a modern style that makes it perfect for everyday use.*

CODE	Size
ABG007A	S
ABG007B	M
ABG007C	L
ABG007D	XL
ABG007E	2XL
ABG007F	3XL



**NEW 2018**



## COMPLETO HQ-RAIN

### HQ-RAIN SUIT

Il completo HQ è costituito da giacca e salopette realizzato in Nylon Taslan 228T con cuciture termosaldate. Questo completo di alta qualità oltre ad avere un'elevata impermeabilità e traspirabilità, si fa apprezzare per la morbidezza del suo tessuto garantendo in qualsiasi condizione meteo avversa, un confort e una fluidità nei movimenti unica nel suo genere.

*The HQ suit is composed by a jacket and a salopette made of Nylon Taslan 228T fabric featuring thermo welding sewing. This high quality suit apart of being breathable and waterproof will be appreciated for the fabric softness and will guarantee a total comfort and protection in any weather situation.*

CODE	Size
ABG006A	M
ABG006B	L
ABG006C	XL
ABG006D	2XL
ABG006E	3XL
ABG006F	4XL



## COMPLETO: POLAR

### POLAR SUIT

La giacca è realizzata con una ampia e soffice imbottitura e micropile interno traspirante che garantisce calore e freschezza ed è dotata di cappuccio removibile a zip. La salopette anch'essa imbottita in soffice materiale traspirante, con bretelle elastiche, ci permette di assecondare i nostri movimenti in fase di pesca in tutta libertà.

*The jacket features a ample and soft breathable micro fleece lining and a removable hood. The salopette features a breathable lining, the elastic suspenders will allow us to move comfortably during the fishing action.*

CODE	Size
SOLD OUT	S
SOLD OUT	M
SOLD OUT	L
SOLD OUT	XL
SOLD OUT	2XL
ABG003F	3XL





## COMPLETO RAINPROOF

### RAINPROOF SUIT

Questo completo impermeabile anti-pioggia è interamente realizzato in poliestere con PU coating, è composto da giacca con cappuccio, completa di quattro tasche esterne ed una interna, e da una salopette con bretelle, acquistabile separatamente. Tutte le cuciture sono termosaldate internamente, garantendo così un vero e proprio isolamento dall'acqua.

*This waterproof, rainproof suit is an absolute must in every angler's wardrobe. Made entirely in PU coated polyester, it consists of a jacket with hood, complete with four outside pockets and one inside and dungarees with braces. All the seams are heat-sealed on the inside, thus guaranteeing total and complete insulation from water.*

#### SALOPETTE

CODE	Size
<b>SOLD OUT</b>	2XL
<b>ABB352F</b>	3XL
<b>ABB352G</b>	4XL

CODE	Size
<b>ABB002A</b>	S
<b>ABB002B</b>	M
<b>ABB002C</b>	L
<b>ABB002D</b>	XL
<b>ABB002E</b>	2XL
<b>ABB002F</b>	3XL
<b>ABB002G</b>	4XL



## MANTELLA ANTIPIOGGIA

### RAIN PROOF BLACK CAPE

Mantella anti-pioggia realizzata in poliestere 190 T con cuciture termosaldate (PVC COATED) è un capo indispensabile da riporre nella nostra borsa durante le competizioni, le battute di pesca in generale o anche nel gavone della barca in quanto una volta ripiegata il suo ingombro è veramente esiguo.

*190T polyester rain proof cape featuring electro welding sewing (PVC Coated), it's a very useful accessory to keep in our tackle bag during the competitions, the fishing outings or in the boat locker, when folded the size is really small.*

CODE	Size
<b>ABG004A</b>	S
<b>SOLD OUT</b>	M
<b>ABG004C</b>	L
<b>ABG004D</b>	XL
<b>ABG004E</b>	2XL
<b>SOLD OUT</b>	3XL



## GIACCA WIND

### WIND JACKET

Capo casual, comodo e versatile che unisce un look accattivante alle caratteristiche di un capo sportivo. Curata in ogni suo aspetto, la giacca wind è dotata di cappuccio, calda imbottitura, interni resistenti, 3 tasche con chiusura waterproof e polsini elasticizzati regolabili.

*Casual comfortable and versatile jacket, that combines a cool look with the characteristics of a sporty clothing. Very well refined it features a hood, elasticized waist and bottom, warm resistant padding, 3 pockets with waterproof zippers, adjustable elastic cuffs.*

CODE	Size
ABB131A	S
ABB131B	M
ABB131C	L
ABB131D	XL
ABB131E	2XL
ABB131F	3XL
ABB131G	2XL/2L
ABB131H	3XL/2L



## GILET LIGHT WEIGHT

Il materiale leggero e resistente di questo Gilet-Piumino, garantisce un comfort elevato ed una protezione dal vento per qualsiasi attività all'aperto. Dotato di 2 comode tasche laterali è perfetto anche per il tempo libero.

*The light and resistant material of this waist coat-jacket assures an high comfort and a wind proof protection for any outdoor activity. It's equipped by two wide side pockets suitable for the free time as well.*

CODE	Size
ABGL002A	S
ABGL002B	M
ABGL002C	L
ABGL002D	XL
ABGL002E	2XL
ABGL002F	3XL



**EXCELLENT**  
performance  
**EXTREME**  
conditions

FOR

# COLMIC STYLE



## GIACCA E BOMBER MAESTRALE

### MAESTRALE JACKET AND BOMBER

Questi due capi di abbigliamento impermeabili, leggeri e confortevoli, realizzati in 320D Taslon con spalmatura in poliuretano (100% nylon) ed interno 100% poliestere, possono essere usati in qualsiasi occasione, comprese le giornate di forte vento e pioggia, consentendo al pescaportivo di rimanere sempre caldo e asciutto.

*These two waterproof items of clothing, light and comfortable, made in 320D Taslon with polyurethane coating (100% nylon) and a 100% polyester lining, can be used on any occasion, even on days of strong wind and rain, allowing the angler to keep warm and dry. These are the reasons why Colmic has come up with the proposal of these new jackets, which differ from each other in terms of style.*

JACKET	
CODE	Size
ABIF051A	S
SOLD OUT	M
SOLD OUT	L
ABIF051D	XL
SOLD OUT	2XL
SOLD OUT	3XL

BOMBER	
CODE	Size
ABIF052A	S
ABIF052B	M
SOLD OUT	L
SOLD OUT	XL
SOLD OUT	2XL
ABIF052F	3XL
SOLD OUT	4XL



## MAGLIA CORAL FLEECE

### CORAL FLEECE JUMPER

Il tessuto CORAL FLEECE è un tipo di materiale innovativo nella realizzazione di pile tecnici di ultima generazione che risulta molto più caldo e traspirante rispetto ai pile di vecchia concezione. La doppia membrana interna in Coral Fleece con la quale viene realizzato questo capo, non solo lo rende confortevole e caldo, ma permette anche di essere protetti completamente dal vento che spesso ci accompagna nelle nostre sessioni sportive invernali.

*The Coral Fleece fabric it's a last generation innovative material used for technical fleece garments, it's much warmer and breathable than old generation fleeces. The double inner Coral Fleece membrane used to manufacture this item make it warm and comfortable but it will also guarantee a complete wind protection during the cold winter months fishing sessions.*

CODE	Size
ABF006A	S
ABF006B	M
ABF006C	L
ABF006D	XL
ABF006E	2XL
ABF006F	3XL





## PILE CORAL FLEECE

Il tessuto CORAL FLEECE è un tipo di materiale innovativo nella realizzazione di pile tecnici di ultima generazione che risulta molto più caldo e traspirante rispetto ai pile di vecchia concezione. La doppia membrana interna in Coral Fleece con la quale viene realizzato questo capo, non solo lo rende confortevole e caldo, ma permette anche di essere protetti completamente dal vento che spesso ci accompagna nelle nostre sessioni sportive invernali.

*The Coral Fleece fabric it's a last generation innovative material used for technical fleece garments, it's much warmer and breathable than old generation fleeces. The double inner Coral Fleece membrane used to manufacture this item make it warm and comfortable but it will also guarantee a complete wind protection during the cold winter months fishing sessions.*

CODE	Size
ABF005A	S
ABF005B	M
ABF005C	L
ABF005D	XL
ABF005E	2XL
ABF005F	3XL



## FELPA NEW ZEALAND LUX

### NEW ZEALAND LUX JUMPER

Calda e morbida felpa realizzata in 100% cotone e mantenendo il design della New Zealand, con l'aggiunta del cappuccio a protezione avvolgente con il quale possiamo ripararci completamente dal freddo e dal vento. Logo Colmic pettorale, cerniera lampo intera e finiture bianco/rosso, donano a questa felpa un look e un design davvero accattivante.

*A soft and warm jumper developed as 100% cotone an evolution of the former New Zeland jumper from last season, an en wrapping hood for more protection against cold and wind has been added. The front Colmic logo and the white/red finishing front zip features an endearing design and look.*

CODE	Size
ABF001A	S
SOLD OUT	M
SOLD OUT	L
SOLD OUT	XL
SOLD OUT	2XL
ABF001F	3XL



## PILE BLU PRIVILEGE

Giacca creata e studiata appositamente per le giornate fredde e ventose. Realizzata in "Micro Polar Pile 320Gr." e con membrana interna, mantiene costante la temperatura corporea per poter affrontare al meglio le nostre battute di pesca sia in mare che in fiume.

*This jacket has been expressly developed for windy cold days. Made of "Micro Polar Fleece 320 gr" and featuring a inner membrane, keeps a constant body temperature to better manage our fishing outing in both fresh and saltwater.*

CODE	Size
ABF007A	S
ABF007B	M
SOLD OUT	L
SOLD OUT	XL
SOLD OUT	2XL
SOLD OUT	3XL







## FELPA UNIVERSAL

### UNIVERSAL JUMPER

Felpa studiata e creata per le stagioni autunnali e primaverili, dove è necessario indossare un capo che non sia troppo pesante. Realizzata in cotone 65% e poliestere 35%, morbida e leggera, si presta egregiamente per le nostre uscite di pesca e per il tempo libero in generale.

*This jumper has been developed for spring and fall weather, where a medium weight cloth is required. Made of 65% cotton and 35% polyester, soft and lightweight, perfect for our fishing outings or as a casual dress.*

CODE	Size
ABF002A	S
ABF002B	M
SOLD OUT	L
SOLD OUT	XL
SOLD OUT	2XL
ABF002F	3XL



## PILE ZIP OFF

Maglione in pile 100% poliestere con trattamento "Anti Peeling". Caldo, morbido e dal design accattivante, la Felpa Pile Zip Off è stata curata in ogni suo più piccolo dettaglio per renderla versatile e pratica allo stesso tempo.

*100% "Anti Peeling" fleece jacket. This warm and soft, nice design Zip Off fleece jacket is perfect in all details, versatile and practical at the same time.*

CODE	Size
ABF003A	S
SOLD OUT	M
SOLD OUT	L
SOLD OUT	XL
ABF003E	2XL
ABF003F	3XL



## MICROPILE COLMIC

Capo in morbida e calda fibra "MicroPile 100% 170 Gr". Versatile e comodo, questo micropile può essere indossato sotto ad una giacca o ad un pile per mantenere un'ulteriore strato termico nelle più fredde giornate invernali.

*100% "Micro fleece" 170gr shirt. This comfortable and versatile micro fleece shirt can be worn under a jacket or a heavier fleece jacket to add a layering for the coldest winter day out.*

CODE	Size
SOLD OUT	S
SOLD OUT	M
SOLD OUT	L
SOLD OUT	XL
ABF004E	2XL
ABF004F	3XL





## PANTALONE RIPSTOP 200GR

### RIPSTOP 200GR PANTS

Pantalone in cotone e poliestere con trama "Ripstop" antistrappo, particolare tessuto elastico al quale nella sua membrana, viene inserita una filatura di nylon che resiste agli strappi ed alle lacerazioni grazie ad un filamento di un nylon più robusto rispetto al resto del materiale. Il sistema "RipStop" fa sì che anche in caso di lacerazioni il taglio non possa espandersi poiché confinato tra i filamenti di nylon più robusti. Molto pratico e leggero, si lava con estrema facilità e si asciuga in brevissimo tempo. Dotato di due tasche "Jeans" e due tasche laterali a coscia, questo pantalone viene rivestito internamente con un tessuto traspirante presentandosi elegante, pratico e molto confortevole per le nostre sessioni di pesca e tempo libero.

*Cotton and polyester anti-tear pant. The particular fabric is made by a strong nylon filament that compared to other materials it can resist to the tears. The "RipStop" system in case of tears permits that the cutting doesn't expand. Very practical and light, it can be easily washed and quickly dried. Equipped of 2 "Jeans" pockets and 2 side pockets, this pant is internally covered with a breathable fabric. It is at the same time elegant, practical and very comfortable for your fishing sessions or your free time.*

CODE	Size
ABP006A	S
ABP006B	M
ABP006C	L
ABP006D	XL
ABP006E	2XL
ABP006F	3XL



## PANTALONE RIPSTOP SPANDEX

### RIPSTOP SPANDEX PANTS

Pantalone in SPANDEX con "Ripstop" antistrappo, particolare tessuto elastico al quale nella sua membrana, viene inserita una filatura di nylon che resiste agli strappi ed alle lacerazioni. Grazie ad un filamento di un nylon più robusto rispetto al resto del materiale, il sistema "RipStop" fa sì che anche in caso di lacerazioni, il taglio non possa espandersi, poiché confinato tra i filamenti di nylon più robusti. Dotato di due tasche "Jeans", due tasche laterali a coscia e rivestito internamente con un tessuto traspirante, questo pantalone si presenta elegante, pratico, comodo e molto confortevole.

*SPANDEX "Ripstop" rip resistance fabric pants, this particular elastic fabric features a special nylon insert rip proof membrane. Thanks to a strongest nylon filament insert the "Ripstop" system will prevent fabric cuts or rips to expand, this because the inside nylon filaments will hold the fabric fibers. Features two "jeans" style pockets, two side leg pockets and is completely covered of a breathable material, this pant is elegant, practical and comfortable.*

CODE	Size
SOLD OUT	S
SOLD OUT	M
SOLD OUT	L
ABP005D	XL
ABP005E	2XL
ABP005F	3XL



# COLMIC STYLE

## PANTALONE ESTIVO BLU

### SUMMER PANTS BLUE

Realizzato in tessuto "Micro Fiber 100 Gr.", questo pratico pantalone trova il suo utilizzo nelle calde giornate estive mantenendo freschezza e libertà nei movimenti grazie al suo morbido tessuto. Fornito di sei comode ed ampie tasche, di cui quattro con zip e due "jeans".

*Made of "Micro Fiber 100 Gr" fabric, this practical pants is perfect for hot summer days, it keeps the lower part of the body fresh and allows freedom of movement thanks to the soft fabric it is made of. Features six ample pockets, four zippered ones and two "jeans" style ones.*



CODE	Size
ABP002A	S
ABP002B	M
ABP002C	L
ABP002D	XL
ABP002E	2XL
ABP002F	3XL



## PANTALONE ESTIVO GRIGIO

### SUMMER PANTS GREY

Leggero e confortevole pantalone lungo estivo, in tessuto "100% poliestere", dotato di 4 tasche laterali (2 a strappo e due con zip), due tasche "jeans" e due posteriori con zip. Questo pratico e morbido tessuto garantisce una freschezza e una libertà nei movimenti unici, anche nelle giornate più calde.

*This long summer pant is light and comfortable made of "100 polyester" with four side pockets (whereof two Velcro pockets and two zip pockets), two "jeans" pockets and two zip ones on the back. This pant is practical, soft, and its tissue preserve the freshness and free moving as well, even in the hottest days.*



CODE	Size
ABP002H	S
<del>SOLD OUT</del>	M
<del>SOLD OUT</del>	L
<del>SOLD OUT</del>	XL
ABP002N	2XL
ABP002O	3XL



**SOLD OUT**

## PANTALONE ESTIVO CORTO GRIGIO

### SUMMER PANTS GREY - SHORT

Leggero e confortevole pantalone corto estivo, in tessuto "100% poliestere", dotato di 2 tasche laterali con zip, due tasche "jeans" e una tasca posteriore con zip. Questo pratico e morbido tessuto garantisce una freschezza e una libertà nei movimenti unici, anche nelle giornate più calde.

*Short comfortable summer pants made of "100% polyester" with side pockets with zip, two "jeans" pockets and one zip pocket on the back. This comfortable tissue guarantees a real freshness and a great free move sensation, even during the hottest days.*



CODE	Size
ABP001H	S
<del>SOLD OUT</del>	M
<del>SOLD OUT</del>	L
<del>SOLD OUT</del>	XL
ABP001O	3XL



## PANTALONE CORTO BLU

### PANTS GREY - SHORT

Leggero e confortevole pantalone corto estivo, in tessuto "100% poliestere", dotato di 2 tasche laterali con zip, due tasche "jeans" e una tasca posteriore con zip. Questo pratico e morbido tessuto garantisce una freschezza e una libertà nei movimenti unici, anche nelle giornate più calde.

*Short comfortable summer pants made of "100% polyester" with side pockets with zip, two "jeans" pockets and one zip pocket on the back. This comfortable tissue guarantees a real freshness and a great free move sensation, even during the hottest days.*



CODE	Size
ABP001A	S
ABP001B	M
ABP001C	L
ABP001D	XL
ABP001E	2XL
ABP001F	3XL



## T-SHIRT & POLO HYDRO TEC



La Polo e le T-shirt HYDRO-TEC hanno un tessuto traspirante che garantisce il massimo del comfort per tutti coloro che hanno bisogno di un capo sportivo comodo e fresco. Le Hydro-Tec sono realizzate con un tessuto altamente innovativo studiato in laboratorio dai nostri esperti del settore tessile, affinché i capi di abbigliamento si asciughino molto rapidamente, favorendo l'espansione e la dispersione dell'umidità verso l'esterno, lasciando così al corpo la sensazione di una piacevole freschezza.

*The hydro-Tec polo shirts are made of a breathable fabric allowing maximum comfort for everybody asking for a comfortable and cool sport garment. The hydro-Tec shirts are made of an innovative fabric developed from textile industry experts to obtain a fast drying garments, to better dissipate heat and humidity, keeping the body at a comfortable temperature.*

T-SHIRT		POLO	
CODE	Size	CODE	Size
ABT009A		ABT008A	S
ABT009B		ABT008B	M
ABT009C		ABT008C	L
ABT009D		ABT008D	XL
ABT009E		ABT008E	2XL
ABT009F	3XL	ABT008F	3XL

**SOLD OUT**



## T-SHIRT & POLO DRY TEC



Comode magliette in tessuto DRY-TEC. Il DRY-TEC è un tessuto che grazie alla tecnologia di ultima generazione si asciuga rapidamente e mantiene la pelle asciutta anche in condizioni di sforzo estremo.

*DRY-TEK comfortable shirts are made of dry-tek tissues thanks to its ultimate generation it dries fast, keeping the skin dry in extreme efforts conditions.*

T-SHIRT		POLO	
CODE	Size	CODE	Size
ABT006A	S	ABT005A	S
ABT006B	M	ABT005B	M
ABT006C	L	ABT005C	L
ABT006D	XL	ABT005D	XL
ABT006E	2XL	ABT005E	2XL
ABT006F	3XL	ABT005F	3XL

# COLMIC STYLE



## T-SHIRT COMPETITION

T/Shirt 100% cotone dal design sportivo con logo "Competition" a contrasto sui fianchi. Personalizzata anche con Logo pettorale Colmic piccolo più logo grande sulla schiena, ed impreziosita con il suo colletto a zip, donano a questa T/Shirt un look elegante abbinato ad una praticità unica.

*100% cotton t-shirt featuring a sport design and "Competition" logo on the side of the t-shirt. Features also a small front chest Colmic logo and a large one on the back, nice zip collar, all the features make this an elegant and uniquely practical clothe.*

CODE	Size
<b>SOLD OUT</b>	S
<b>SOLD OUT</b>	M
<b>ABT003C</b>	L
<b>ABT003D</b>	XL
<b>ABT003E</b>	2XL
<b>ABT003F</b>	3XL



## T-SHIRT

T/Shirt 100% cotone personalizzata con logo Colmic pettorale grande a banda e logo posteriore piccolo situato sul collo.

*100% Cotton fabric T-shirt featuring a large Colmic chest logo and small rear one on the neck.*

### COLMIC 1978

CODE	Size
<b>ABT007A</b>	S
<b>ABT007B</b>	M
<b>ABT007C</b>	L
<b>ABT007D</b>	XL
<b>ABT007E</b>	2XL
<b>ABT007F</b>	3XL

### BLUE

CODE	Size
<b>SOLD OUT</b>	S
<b>SOLD OUT</b>	M
<b>ABT002C</b>	L
<b>ABT002D</b>	XL
<b>ABT002E</b>	2XL
<b>SOLD OUT</b>	3XL



## GREMBIULE COMPETITION TROTA LAGO

APRON COMPETITION: TROTA LAGO

**CODE: ABGR001**

Pratico grembiule da gara realizzato in poliestere 65% e cotone 35%. Dotato di due grandi tasche laterali e una ampia tasca a marsupio pettorale, è l'ideale per le competizioni Trota Lago, ma grazie alla sua versatilità, trova il suo utilizzo anche in altre discipline come Canna da Riva o Surf Casting.

*Very practical competition apron made of a mix of 65% polyester and 35% cotton. Features two large side pockets and a ample front chest pocket, perfect for still water trout competitions but thanks to its great versatility it's perfect also for saltwater bank fishing competitions and surf casting.*

## GREMBIULE COMPETITION TROTA TORRENTE

APRON COMPETITION: TROTA TORRENTE

**CODE: ABGR002**

Grembiule da gara realizzato in poliestere 65% e cotone 35%. Si differenzia dal "Trota Lago" sulla tasca pettorale superiore dove anziché intera viene divisa in due scomparti con aggiunta all'esterno di inserti porta stecche avvolgibile. Dotato inoltre di un tascone laterale unica e una tasca pettorale a marsupio con chiusura a strappo, anche questo grembiule trova il suo utilizzo in altre discipline come Canna Da Riva e Surf Casting.

*Apron race made in 65% polyester and 35% cotton. It differs from the "Trota Lago" on the upper chest pocket which is divided into two compartments with the outside addition of inserts to carry the lines. Equipped with a large pocket and a chest pocket pouch with velcro closure, this apron finds its use in disciplines such as beach ledgering and Surf Casting.*



## BANDANA TUBE COLMIC

**CODE: CLC36**





## CAPPELLI

CAP

	Code	Size
A	<b>SOLD OUT</b>	Cappello in cotone Bianco - WhiteCotton cap
B	<b>SOLD OUT</b>	Cappello in cotone Blu - Blue Cotton cap
C	<b>SOLD OUT</b>	Cappello in cotone Blu + LED - Blue Cotton cap + LED
D	<b>CLC41</b>	Visiera Colmic - Colmic Head Visor
E	<b>SOLD OUT</b>	Cappello Blu Bianco c/rete - Blue White Mash Cap

## PAPALINA NERA INTERNO IN PILE

SKULL CAP INTERNAL PILE

CODE: CLC46



## SCALDACOLLO IN PILE BLU LUX

FLEECE NECK WARMER LUX

CODE: CLC25A

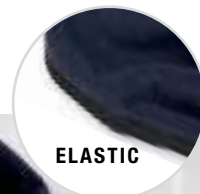

ELASTIC

## BANDANA CON CAPPUCCIO

BANDANA W/CAP

CODE: CLC47



**EXTREME  
COMPETITION**

**COLMIC**

**RED SERIES**



**IMBOTTITO  
PADDED**



**IMBOTTITO  
PADDED**



**RBS SERIES**

Foderi imbottiti porta roubaissienne dotati di un'ampia tasca porta paleria e ombrellone con apertura a libro. Tracolla imbottita sulla parte posteriore ed un'extra maniglia sul fianco laterale rendono questi portacanne molto agevoli nel trasporto. Cerniere Waterproof e cuciture antistrappo sono particolari essenziali per qualsiasi garista. RBS XXL è oltretutto dotato di base rigida in Eva

*Padded pole holders, equipped with a large pocket for poles and umbrella with book opening. Padded shoulder belt on the back and an extra handle on the side, make these holdall very easy to carry. Waterproof zip and anti-tear seam are essential details for any fisherman. RBS XXL is moreover equipped with a rigid Eva structure at its base.*

**RBS XXL CODE: PR215**

DESCRIPTION
6 tubi RBS + 10 tubi Top Kits
6 tubes RBS + 10 tubes Top Kits

**RBS XL CODE: PR214**

DESCRIPTION
6 tubi RBS + 10 tubi Top Kits
6 tubes RBS + 10 tubes Top Kits





**IMBOTTITO  
PADDED**

## RACE

**CODE: PR207**

Il porta canne RACE è stato studiato appositamente per il contenimento di RBS e tubi, nonché di paleria varia, all'interno di un'ampia tasca esterna laterale. Il RACE è un fodero pratico e robusto, proposto ad un prezzo davvero interessante. Oltre che RBS, questo porta canne, può alloggiare al suo interno canne ripartite in due sezioni.

*The RACE holdall is perfect to hold RBS, tubes and banksticks. It features a wide external pocket. Race is practical an resistant holdall, at a very interesting price. In addition to RBS and banksticks Race can contain many sectioned rods.*

200  
22 8+15  
cm

Tasca / Pocket  
6cmx18cm  
h.125cm

# HARD CASE

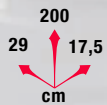

Tasca / Pocket  
6cmx13cm  
h.135cm



Tasca / Pocket  
6cmx13cm  
h.135cm



## RBS SERIES

Foderi rigidi antiurto da Roubaisienne, realizzati in scomparti divisi e dotati di tasca laterale. Questi foderi dalle generose dimensioni, ci permettono di trasportare la nostra RBS con i suoi relativi Kit senza rischi di rotture accidentali grazie alla sua membrana rigida.

*Shock proof hard case Roubaisienne holdall. Featuring in compartments divided and equipped with a side pocket. This generous capacity holdalls will allow us to transport our RBS and all the Kits, avoiding damages due to its inner rigid core.*

### RBS XXL CODE: PR500

#### DESCRIPTION

4 tubi RBS + 6 tubi Top Kits

4 tubes RBS + 6 tubes Top Kits

### RBS XL CODE: PR501

#### DESCRIPTION

2 tubi RBS + 5 tubi Top Kits

2 tubes RBS + 5 tubes Top Kits

## P/PUNTE

### CODE: PR502

Portapunte rigido realizzato per il trasporto dei nostri kit Rbs. Di dimensioni più grandi rispetto al precedente, in questo nuovo portapunte, possiamo inserirci fino a 6 kit in 5 pezzi senza il rischio di rotture accidentali, grazie alla sua membrana interna rigida.

*Hard case kits holder expressly made to carry spare pole top kits. This top kits holder is larger than the former one, the new one will hold up to 6 top kits in 5 pcs without the risk of damaging them, thanks to its rigid inner case.*

# ROD HOLDER



170  
16 18  
cm  
Tasca / Pocket  
6cmx13cm  
h.120cm



190  
16 18  
cm  
Tasca / Pocket  
6cmx13cm  
h.120cm

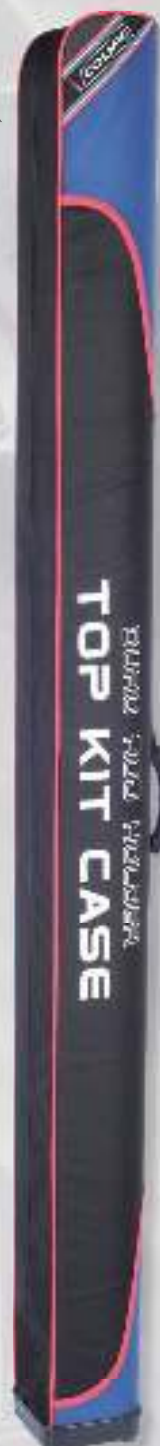

185  
15 14  
cm

## BOLO-01

CODE: PR503

Portacanne rigido antiurto realizzato per il trasporto delle bolognesi. E' dotato di una tasca laterale utilissima per riporvi al suo intero tutti gli accessori inerenti alla pesca con bolognese, come manici di guadino e paletti multiuso.

*Shock proof hard case rod holdall expressly made for bolo rods. It features a side pocket very useful to carry accessories like landing net poles and bank sticks.*

## FEEDER

CODE: PR504

Portacanne rigido antiurto realizzato per il trasporto delle canne da Feeder montate. La sua altezza di 190 cm, ci permette di alloggiare al suo interno anche le canne più lunghe. E' dotato di una tasca laterale utilissima per riporvi al suo intero tutti gli accessori più ingombranti utilizzati nel Feeder, come bracci telescopici e ombrelli.

*Hard case rod holdall expressly made to carry rigged Feeder rods. The 190 cms height will allow to hold also the longer rods. It features a very useful side pocket that will conveniently hold feeder fishing accessories like bank sticks, feeder arms or brollies.*

## TOP KIT CASE

CODE: PR505

Può contenere KIT a due pezzi con lenze già montate, due 4° elementi match e due 3° elementi carpa inseriti l'uno nell'altro e la sua struttura rigida ci assicura da rotture accidentali. Può essere utilizzato anche per il trasporto di canne da Surf casting, Beach ledgering e tutto ciò che riteniamo utile per le nostre battute di pesca.

*Its height of 185cm it may contain KIT in two pieces with already rigged lines, two 4° match sections and two 3° carp sections inserted one in the other. Its rigid structure assures us from accidental breakage. It can also be used for the transport of Surf casting rods, Beach ledgering and everything that we wish for our fishing time.*



## PRAGA

Foderi dalla forma semplice ed essenziali che li rendono adatti al trasporto di qualsiasi attrezzo da pesca. Entrambi dotati di tasca laterale porta ombrellone o e porta paleria.

*Simple and basic bags suitable to carry any kind of fishing tackles. Both features with a side pocket, designed as umbrella or poles holders.*



Tasca / Pocket  
h.115cm

**PRAGA 190**  
CODE: PR201



Tasca / Pocket  
h.115cm

**PRAGA 170**  
CODE: PR201A



Tasca / Pocket  
h.115cm

**PRAGA 160**  
CODE: PR202



## BARBO

La serie BARBO è in grado di contenere da RBS pezzate corte a qualunque altra canna da pesca non montata, con mulinello. E' dotata di tasca laterale porta paleria e ombrellone e la tracolla.

*The Barbo serie, can contain poles with short sections and any other not assembled rod. It features a side pocket for poles and umbrellas and shoulder belt.*

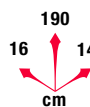

Tasca / Pocket  
h.110cm

**BARBO 190**  
CODE: PR205A

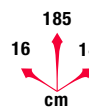

Tasca / Pocket  
h.110cm

**BARBO 185**  
CODE: PR205

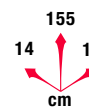

Tasca / Pocket  
h.90cm

**BARBO 155**  
CODE: PR206

# TREVIRA

# BOLO SERIES

Tramite gli specifici comparti sagomati, questi foderi sono stati studiati per contenere bolognesi ed inglesi montate con mulinelli. Un ulteriore comparto non sagomato, dritto, vi sarà estremamente utile per ombrelloni, canne fisse e quant'altro. Ai lati sono presenti una tasca porta paleria generica, con chiusura a stretch, ed una tasca bassa per paletti o altri oggetti di pari dimensioni. La doppia tracolla a zaino vi faciliterà il trasporto.

*With their special shaped compartments, these rod holdalls have been designed to hold Bolognese and match fishing rods complete with reels. Another unshaped, straight compartment is extremely useful for holding brallies, whips and anything else you wish. On the sides are multi pockets, with stretch closure, and a shorter pocket for banksticks or other objects of the same dimensions. The double backpack-style straps make it particularly easy to carry.*

BORSETTERIA-LUGGAGE



170 30  
13 (10x3)  
cm  
Tasca / Pocket  
h.97cm

## BOLO 002

CODE: PR213A

### DESCRIPTION

4 canne montate

4 assembled rods



170 40  
13 (10x4)  
cm  
Tasca / Pocket  
h.97cm

## BOLO 003

CODE: PR213B

### DESCRIPTION

6 canne montate

6 assembled rods

## BOLO 004

CODE: PR213C

### DESCRIPTION

8 canne montate

8 assembled rods



170 50  
13 (10x5)  
cm  
Tasca / Pocket  
h.97cm



160  
15 16  
cm  
Tasca / Pocket  
h.90cm



140  
15 16  
cm



155  
20 16  
cm  
Tasca / Pocket  
h.87cm

## COUNTRY 160

**CODE: PR203**

IL COUNTRY è provvisto di una tasca laterale per la paleria, di cinghia doppia per il trasporto a zaino e può contenere tranquillamente tre canne, con abbinato il mulinello di taglia fino a 4000.

*The COUNTRY is equipped with a side pocket and a double strap for carrying rucksack-style. It can easily hold three rods complete with reels up to 4000.*

## COUNTRY 140

**CODE: PR203A**

IL COUNTRY 140 è nato per il trasporto delle bolognesi di media lunghezza. Dotato di cinghia doppia per il trasporto a zaino come il fratello maggiore può contenere tranquillamente tre canne, con abbinato il mulinello di taglia fino a 4000.

*The COUNTRY 140 has been especially conceived to transport medium length bolognese rods. Same as its "older brother" COUNTRY, this new model it is equipped with a double strap for carrying rucksack-style and it can easily hold three rods complete with reels up to 4000.*

## CAVEDANO

**CODE: PR204**

Il porta canne CAVEDANO si presta a contenere canne bolognesi, ledgering, canne fisse, canne da surf telescopiche o in tre pezzi, a seconda delle varie necessità. Esso è dotato di due tasche laterali porta paleria e di una tasca anteriore esterna, posta nella zona inferiore.

*The CAVEDANO is perfect for holding Bolognese and beach ledgering rods, whips and telescopic or three-section surf rods, depending on the angler's specific requirements. It also has two side pockets for poles or banksticks and an outside pocket in the lower front section which can be used to carry any equipment, fixing them with the special velcro strips on the outside.*



## GIGLIO

**CODE: PR200**

Il fodero GIGLIO è stato realizzato per consentire il trasporto di due canne bolognesi montate. E' provvisto di cinghia a tracolla e di una tasca laterale portaoggetti, alta 28 cm.

*The GIGLIO rod holdall has been designed to transport of two assembled Bolognese rods. It has a shoulder strap in Cordura and a multipurpose side pocket 28 cm high.*



## SCOGLIERA

**CODE: PR208**

Porta canne imbottito, ideato appositamente per ridurre al minimo il bagaglio, in caso di lunghi spostamenti a piedi. Il fodero SCOGLIERA può ospitare al suo interno bolognesi montate, canne telescopiche, ledgering o canne da surf casting, mentre nelle 4 tasche laterali possono essere riposte attrezzature di vario genere.

*This padded rod holdall has been designed specifically to reduce luggage in the case of long hikes on foot. The SCOGLIERA holdall can contain mounted Bolognese rods, telescopic rods, beach ledgering and surf casting rods, while the 4 side pockets can be stowed with various equipment.*

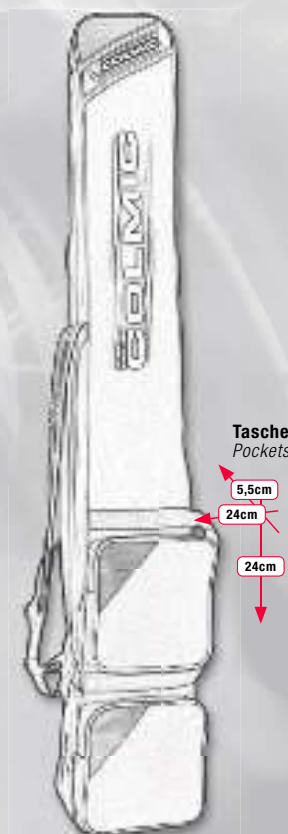

Tasche  
Pockets

5,5cm

24cm

24cm

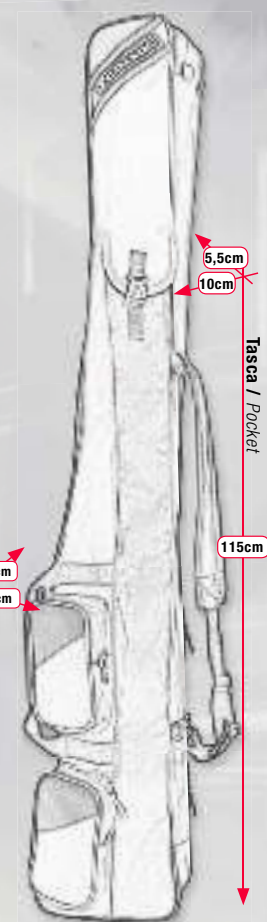

5,5cm

10cm

Tasca / Pocket

115cm

Tasche/Pockets

5,5cm

12cm

22cm

# SURF SERIES

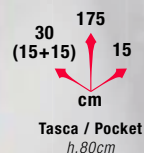
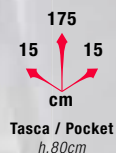
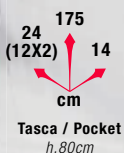

## SURF EXTRA

CODE: PR213

### DESCRIPTION

2 compartì sagomati fondo rigido in Eva  
*2 shaped compartments with Eva*

## SURF 1

CODE: PR209

### DESCRIPTION

1 comparto sagomato  
*1 shaped compartment*

## SURF 2

CODE: PR211

### DESCRIPTION

2 compartì sagomati  
*2 shaped compartments*



# TREVIRA

Foderi studiati per il trasporto di canne da Surfcasting o Beach Ledgering. Infatti i compartimenti sagomati ad un'altezza di 80 cm, permettono di alloggiare le canne con mulinelli montati. Tutti sono dotati di tasca laterale porta paleria e di cinghia a tracolla in cordura.

*Holdalls conceived for the transport of Surfcasting or Beach Ledgering rods. The compartments, specially shaped at the height of 80 cm, are designed to fit rods with mounted reels. They all feature a side pocket for banksticks, and a shoulder strap in Cordura.*



30  
(15+15)  
175  
15  
cm  
Tasca / Pocket  
h.80cm



45  
(15+15+15)  
175  
15  
cm  
Tasca / Pocket  
h.80cm

## SURF 1 + 1

CODE: PR210

### DESCRIPTION

1 comparto + 1 comparto sagomato

1 compartment + 1 shaped compartment

## SURF 2 + 1

CODE: PR212

### DESCRIPTION

1 comparto + 2 comparto sagomati

1 compartment + 2 shaped compartments

## COLMIC-TECH

La ricerca Colmic si dedica da tempo all'innovazione dei materiali nel campo della pesca sportiva. Sempre attenti a quelle che sono le novità abbiamo sviluppato prodotti tecnici con l'utilizzo di un nuovo tessuto, il CLM-TECH che oltre ad eccellere in doti di robustezza estrema e inalterabilità del colore, viene assemblato con il preciso obiettivo di durare nel tempo. La speciale trama ad elevata densità, le doppie cuciture e le cerniere rinforzate rendono il prodotto finito pressoché eterno. I test, effettuati in condizioni estreme, restituiscono un tessuto invariato in naturalezza dei colori e integrità. Un'altra caratteristica del CLM-TECH è la facilità estrema nella pulizia, il lavaggio risulterà estremamente agevole con una rapida asciugatura.

*Colmic development program is focusing on new materials in the fishing tackles industry since a long time ago, always sensible to the new technologies we developed new products using a new fabric, the CLM-TECH. It excels in durability, strength and color inalterability. The special high density weave, the double seams and the reinforced zips will result in a final product that will last for a lifetime. The tests, made in extreme conditions, gave an unchanged product both in terms of color shade and integrity. The CLM-TECH is the easy cleaning: the cleaning and drying processes will result fast and simple.*



50  
40 78  
cm

HARD  
WEVA

## LONDRA

CODE: BO250

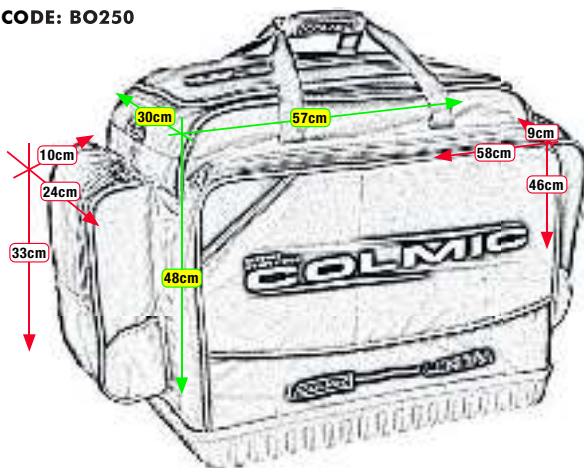

# TREVIRA



## PARIGI

CODE: BO251

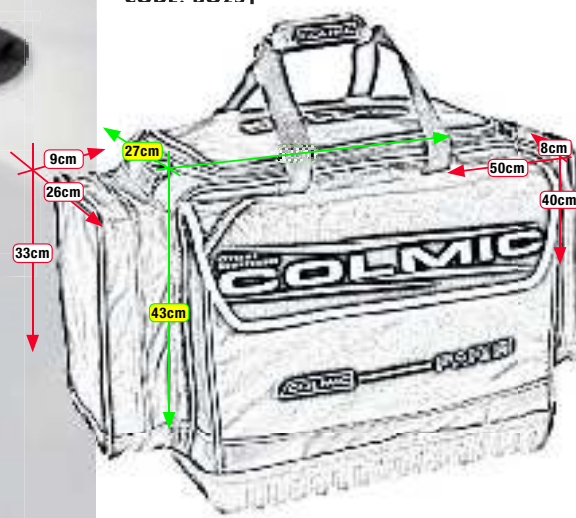

## ALASKA COOLER

CODE: BO252





**CATAPULT**

**CODE: BO201**

Comoda borsa capace di contenere fino a sei fionde.  
Handy bag that can hold up to six catapults.

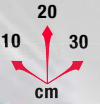

**ATENE**

Piccole borse porta oggetti con tasca frontale e tracolla. Economiche e funzionali.

Small carryall with front pocket and shoulder strap. Cheap and practical.

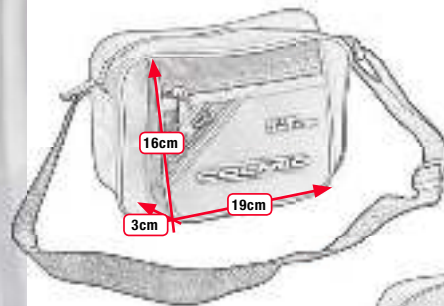

**ATENE**

**CODE: BO202**

**ATENE XXL**

**CODE: BO203**

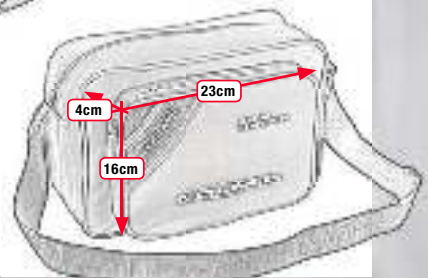

**SAFARI**

**CODE: BO201A**

Questa piccola borsa in trevira. Capace di contenere tutto l'essenziale, per molte delle tecniche praticabili in acque interne e salse.

This small bag made of Trevira, with a major focus on detail, is provided with a spacious inner compartment and features handy extra pockets on the front.

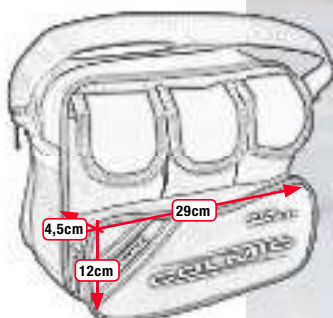



**IMBOTTITO  
PADDED**



## ARNO DURO

**CODE: BO204**

Comoda borsa imbottita adatta a contenere accessori, scatole e quant'altro. In tutti i lati sono state applicati dei pannelli in plastica rigida per stabilizzare la borsa anche se vuota, da qui il suo marchio "Duro Bag".

*Comfortable padded bag suitable to hold several accessories, cans and more. All sides feature rigid plastic panels to stabilize it even if it is empty, hence its name "Duro Bag".*



## ARNO COOLER

**CODE: BO205**

Borsa frigo, laminata interamente con materiale isolante di eccellente qualità per essere utilizzata sia come porta esche che porta vivande. Da qui il suo marchio "Cooler Bag".

*Freezer bag, entirely laminated with high quality insulating material. It can be used as a bait holder or to carry food. Hence his trademark "Cooler Bag".*



## FRIGO RIO

**CODE: BO209**

Borsa frigo, laminata internamente con materiale isolante di eccellente qualità, può essere utilizzata sia come porta esche che come porta vivande.

*This cool bag, laminated inside with insulating material of excellent quality, can be used both as a bait bag and in general for carrying food and drinks.*

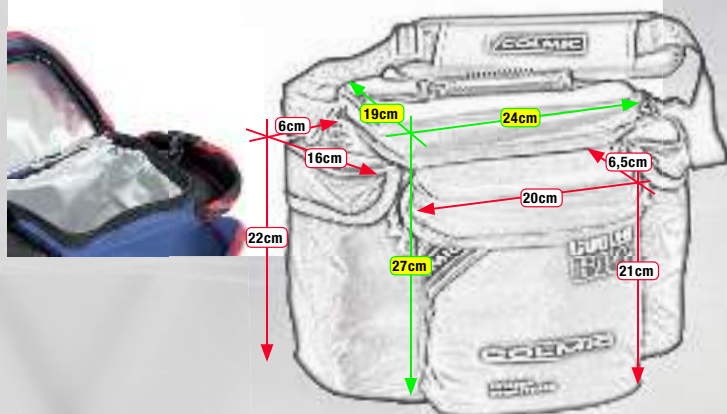

**IMBOTTITO  
PADDED**



## NEW YORK

**CODE: BO206**

Praticissima borsa di dimensioni mediopiccole.

*This ultra-practical bag of medium-small size.*

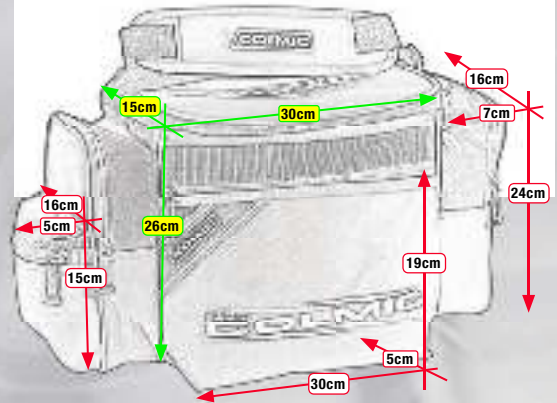

## LAS VEGAS

**CODE: BO207**

L'apertura di questa borsa è del tipo a "Binario" che aiuta l'apertura e chiusura anche con una sola mano. Borsa molto confortevole e pratica da usare dotata di rivestimento interno con pannelli in plastica rigida. Da qui il suo marchio "Duro Bag".

*The opening of this bag is "Binary" which facilitates the opening and closing with one hand only. A very practical and comfortable bag with an inner lining with rigid plastic panels. Hence his trademark "Duro Bag".*

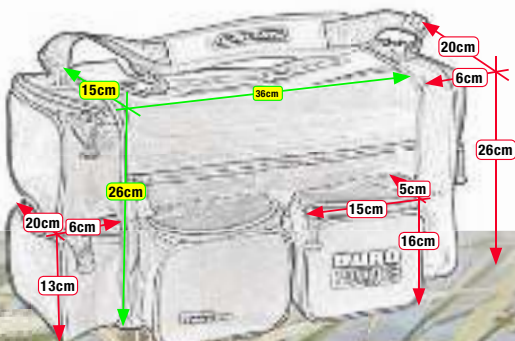

# TREVIRA



## DUBLINO

CODE: BO208

Nata dal successo della borsa Herakles Pro3600, abbiamo portato queste dimensioni anche nella serie di Colmic con l'aggiunta di pannelli interni in plastica rigida e qualche tasca modificata per renderla più idonea sia in acque interne che saline. Anche lei porta il marchio "Duro Bag".

*Born from the success of the Herakles Pro3600 bag, we brought this bag also into the Colmic range, adding interior panels made of rigid plastic and some pockets. These changes make the Dublino a very suitable bag for both fresh and salt waters. Marked "Duro Bag".*

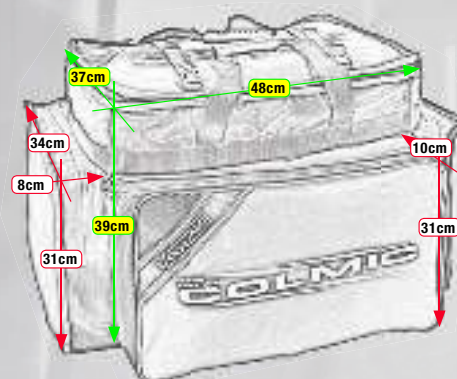
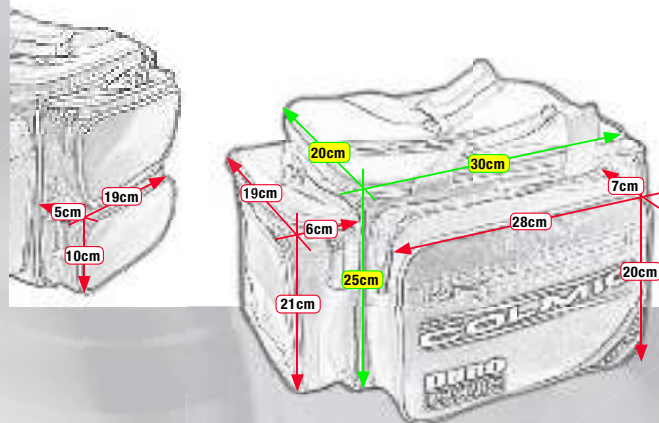

## FIRENZE

CODE: BO210

Evoluzione della serie Firenze, questa borsa ha le stesse dimensioni e caratteristiche che ormai hanno determinato e classificato questa borsa come un simbolo Colmic. Il miglioramento più significativo è stato riportato sulla tasca frontale munendola di Zip con dimensione adatte a molte delle nasse e stese di guadino presenti su mercato.

*Evolution of its elder sister "Firenze", this bag can be considered a symbol of Colmic. The major improvement is the addition of a frontal zipped pocket ideal for the carriage of the landing nets and the landing head on the market.*

## ROLLER

Molto capienti, consentono di stivare ordinatamente rulli per roubaissienne, appoggia kit, fionde, contenitori, mulinelli, indumenti o qualsiasi altra cosa.

*Extremely roomy bags, it contain rollers, pole rests, catapults, reels, clothe and anything else you clothes like.*

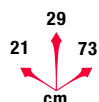

**ROLLER**  
CODE: BO211

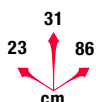

**ROLLER XXL**  
CODE: BO2110

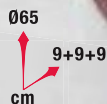

## PORTA NASSA

### P/NASSA SINGOLO

CODE: BO212

### P/NASSA SINGOLO CON TASCA

CODE: BO213

### P/NASSA DOPPIO CON TASCA

CODE: BO214

## BIG GAME

CODE: PR119



Colmic ha realizzato questo funzionale fodero in nylon spalmato 600/D, utile ad alloggiare canne da barca monopezzo, complete di rotanti. Il porta canne BIG GAME, è capace di contenere due canne da traina con mulinello rotante anche di grosse dimensioni, oppure quattro/cinque canne monopezzo da vertical jigging, inchiku e cabura, armate di rotanti più piccoli. Dotato sia di tracolla che di maniglie laterali, questo fodero risulta facilissimo da trasportare. Uno stretch posto all'apice del porta canne, permette di regolarne l'altezza, a seconda della lunghezza delle canne riposte al suo interno.

*Colmic has created this practical holdall to hold one-piece boat rods complete with trolling reels, the BIG GAME rod holdall can hold two trolling rods with even large trolling reels, or four/five one-piece rods for vertical jigging, inchiku and kabura, equipped with smaller trolling reels. Complete with both shoulder strap and side handles, this holdall is easy to carry. A stretch section at the top of the holdall makes it possible to adjust the height depending on the length of the rods inside. Another of the many Colmic novelties that is sure to leave its mark.*





## SURF BIG

CODE: BO211B

La borsa surf Big è caratterizzata da un ampio scomparto superiore rigido nel quale possono essere alloggiati mulinelli, bobine extra, e tutti i modelli di bobine e tavolette in neoprene con travi e braccioli montati. Nello scomparto inferiore invece sono state inserite 3 comode scatole estraibili per alloggiare tutta la minuteria necessaria per soddisfare le esigenze di ogni pescatore. Dotata inoltre anche di due comode tasche laterali con zip e una tasca superiore con zip sopra al vano rigido.

*The Surf Big bag features a large upper hard case compartment with room enough to store reels, spare spools, all eva ready rigs spools and winders. In the lower compartment instead are inserted 3 practical large plastic tackle boxes to store all terminal tackles needed by all fishermen. It also features two side zippered bags and an upper zippered bag positioned above the hard case compartment.*

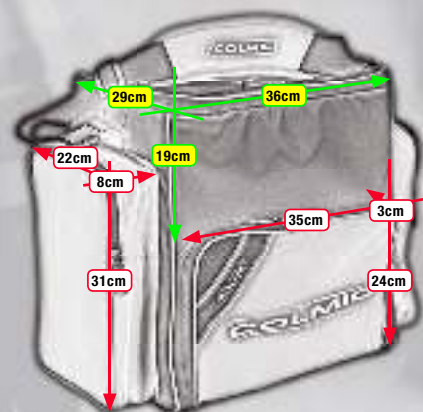
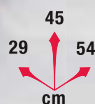

## SURF MEDIUM

CODE: BO211A

La borsa surf medium è caratterizzata da uno scomparto superiore rigido nel quale possono essere alloggiate bobine di scorta dei nostri mulinelli e bobine in neoprene con travi e braccioli montati. Nello scomparto inferiore invece sono state inserite 4 comode scatole estraibili (mod.3600) per alloggiare tutta la minuteria necessaria per soddisfare le esigenze di ogni pescatore. Dotata inoltre di una tasca superiore con zip sopra al vano rigido.

*The Surf Medium features an upper hard case compartment where is possible to store spare spools and eva ready rigs spools. The lower compartment features 5 removable plastic boxes (mod.3600) to store all the terminal tackles every fisherman will need. It also features a upper zippered bag positioned above the hard case.*

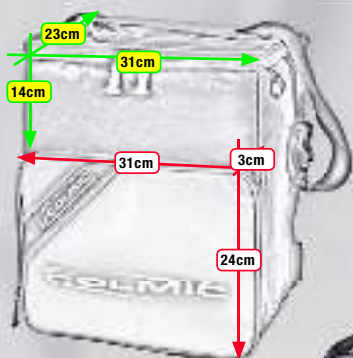

**PVC MATERIAL**

SALDATURE A TENUTA STAGNA – CERNIERATI  
ANTICORROSIONE WATERPROOF

- Preserva gli ambienti dai cattivi odori
- Evita perdite liquide residue
- Leggero
- Indistruttibile
- Ripiegabile salva spazio

WATERTIGHT WELDING – ANTI CORROSION WATERPROOF  
ZIPPERS

- Protects the surroundings from bad smells
- Prevents liquid seepage
- Light
- Indestructible
- Can be folded to save space

**PANTERA**

Dotato di maniglie ergonomiche rigide in plastica e di tracolla, consente una facilità di trasporto unica; la chiusura con cerniera che funge da coperchio semi rigido, permette una rapida collocazione dei materiali al suo interno.

*Equipped with stiff ergonomic handles in plastic and shoulder strap for a genuinely unique ease of transport. The zipper closure that also functions as a semi-stiff lid, makes it easy to stow your gear inside. Available in two sizes, it can also hold sieves, small basins and other similar articles.*

**PANTERA LARGE**

CODE: BOXEVA04A

**SOLD OUT**



**NEW 2018**

**PANTERA MEDIA**

CODE: BOXEVA04

**SOLD OUT**

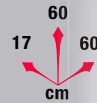

**NEW 2018**

**PUMA**

Viene proposto in versione quadrata e circolare, ed in 2 diverse misure per ognuna di queste forme.

*Puma is offered in a squared and in a round version in 2 sizes each model.*



**NEW 2018**



**SOLD OUT**

CODE: BOXEVA05B

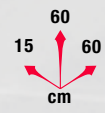

CODE: BOXEVA05C



# PVC MATERIAL

## LION SERIES

Le maniglie ergonomiche in materiale plastico sono una delle peculiarità principali di questo articolo che può essere utilizzato per varie finalità.

*The ergonomic plastic handles are one of the main features of this interesting article, which can be used for a variety of different functions.*

### LION MEDIUM

CC **SOLD OUT** 115



IDEAL FOR  
4 BOXES  
SIZES "3700"



### LION SMALL

CC **SOLD OUT** 4



IDEAL FOR  
5 BOXES  
SIZES "3600"



### LION EXTRA/S

CODE: BOXEVA16

## KANGURO

CC **SOLD OUT**

La KANGURO, vi consentirà di tenere ben in ordine le lenze già pronte e avvolte sulle stecche, le bobine dei mulinelli, fionde, minuterie varie, nylon, bobine, galleggianti e molto altro, preservando sempre il tutto dalle intemperie e dai raggi del sole.

*The KANGURO will allow you to keep already wound lines, reel spools, catapults, sundry small accessories, nylons, spools, floats and much more besides in perfect order, while also protecting them from bad weather and from sunlight.*





## JAGUAR BIG

CODE: BOXEVA07



## JAGUAR SMALL

CODE: BOXEVA08



## JAGUAR

Questa innovativa borsa rigida in PVC, è molto pratica ed eclettica. La possibilità di dividere l'oggetto in due parti distinte e utilizzabili indipendentemente l'una dall'altra, la rende adattabile a qualsiasi necessità di trasporto e di pesca. La borsa, proposta in due diverse misure, sono entrambe isolate termicamente da una lamina interna di materiale coibente. Le due parti si prestano ad essere utilizzate per riporre qualsiasi oggetto: minuteria, scatole, vestiario, nylon, esche vive, mulinelli, bobine ed altro ancora.

*This innovative hard bag in PVC is extremely practical and eclectic. The possibility of dividing the bag into two completely separate parts that can be used independently means that it can be adapted to any transport and fishing requirement. Proposed in two different sizes, the bag is thermally insulated by an inner layer of insulating material. Both parts can be used for stowing away any object at all: small fishing accessories, tins and boxes, clothes, nylons, live bait, reels, spools and practically anything else you can imagine.*

## BAIT BOX

CODE: BOXEVA18

Pratico e comodo contenitore per esche in Pvc con tasca porta ossigenatore e chiusura a zip completamente impermeabile. Adatto per il contenere il Ver De Vase che avanza a fine delle nostre sessioni di prova, per poterlo mantenere fresco e vitale per un'ulteriore successivo utilizzo. Ideale anche per tutte le altre esche che vogliamo mantenere vive come ad esempio i gamberetti per la pesca in mare alla spigola.

*Practical and useful PVC bait box featuring an oxygenator pocket and a waterproof zippered closure. Perfect to hold Ver De Vase left from the fishing outings and to keep it fresh and vital for the next day. Perfect also for all other live baits like for example shrimps used in the sea bass fishing in the salt.*



## MOBY

CODE: BOXEVA01

Il pratico cordino del quale è dotato, permette di raccogliere l'acqua anche da altezze considerevoli, con estrema facilità; quindi risulta ideale per la pesca agonistica, in scogliera, per la pesca dalla spiaggia o semplicemente da tenere in barca.

*The practical cord makes it possible to collect water very easily even from considerable heights; it is consequently perfect for competition fishing, for fishing from rocks or from the beach, or simply just to use on a boat.*



## KOALA

CODE: **SOLD OUT**

Il KOALA è un secchiello quadrato in PVC, con supporto in metallo da agganciare alla cintura o sull'orlo degli waders, studiato appositamente per contenere esche di qualsiasi tipo e preservarle sempre ben asciutte.

*The KOALA is a square bucket made of PVC, with a metal brace that you can attach to your belt or to the top of your waders. It is specially designed to hold bait of all kinds and keep them nice and dry.*



## PONGO

CODE: BOXEVA12A

La serie si arricchisce di una nuova versione speciale, il PORTA PASTURA PONGO, che con un diametro di 57 cm e un'altezza di 17 cm, agevola e velocizza le operazioni di miscelamento delle vostre terre da gara.

*The latest addition to this range is the new special version which - with a diameter of 57 cm and a height of 17 cm - makes it even easier to mix your competition groundbait.*



## MULTI BOX

CODE: BOXEVA17

Questa "Matrioska", è composta da un leggerissimo ed ampio contenitore rettangolare in pvc, e da altri 4 contenitori più piccoli inseriti l'uno dentro l'altro. La MultiBoxes può risultare utile per il contenimento di varie esche, pellets, per la preparazione della pastura e per qualsiasi altra esigenze del momento o delle tecniche specifiche. Il contenitore "madre", quello più grande, è dotato inoltre di foro laterale e può essere attaccato alla cintura quando si pesca in acqua con gli waders. Utile anche per la pesca da natante: massima resa, minimo ingombro.

*This "Matrioska" style box set is composed of a very light and ample rectangular PVC box and 4 smaller ones in different sizes that can be stored one inside the other. This Multi-Box will be extremely useful to hold different baits, pellets, for ground bait and mixes preparation and for any other different use or specific fishing technique needs. The larger "mother" box is equipped with a side belt attachment and can be used for wading fishing. Perfect also for boat fishing, maximum utility, minimum size.*

	SIZE
1 BIG	38cm x 24cm - H.15cm
2 MEDIUM	22cm x 17,5cm - H.14cm
2 SMALL	20cm x 16cm - H.13cm





## VARANO

Una delle caratteristiche essenziali di questi porta pastura è la loro forma conica: questa peculiarità rende tali oggetti perfettamente impilabili l'uno dentro l'altro, riducendo quindi ingombri e facilitando il trasporto.

*One of the essential features of these groundbait boxes is their conical shape: this means that they can be piled perfectly one inside the other for easy storage and transport.*

CODE	SIZE
BOXEVA10	Ø30cm - H.19cm
BOXEVA11	Ø37cm - H.22cm
BOXEVA12	Ø43cm - H.25cm

## VARANO W/COVER SERIES

CODE	SIZE
BOXEVA19	Ø30cm - H.17cm
BOXEVA20	Ø37cm - H.20cm
BOXEVA21	Ø45cm - H.28cm

Serie di pasturatori in tre differenti diametri dotati di coperchio con chiusura a zip. Questa particolarità, rende i pasturatori Varano adatti ad essere impiegati anche con condizioni di pioggia grazie alla sua totale impermeabilità una volta chiuso il coperchio. La serie dei Varano è composta da tre pasturatori in PVC inseribili l'uno nell'altro per agevolare il trasporto e la stiva. Inoltre, è possibile di inserire nella misura più grande (45\* H28) un secchio da 17 Lt, coprendolo totalmente con la sua chiusura a zip.

*PVC ground bait buckets series available in three different diameters featuring a zippered top, this particular feature guarantee a perfect use of the buckets in rainy conditions thanks to their total waterproof when the top is zippered. The Varano series features three different PVC buckets that will fit one inside the other for a more convenient storage and transportation. The bigger size (45\* H28) will perfectly fit a 17 liters plastic bucket, sealing it perfectly thanks to the zip closure.*



## VARANO W/COVER & LOOP

Con caratteristiche del tutto simili alla versione Varano w/cover, questi pasturatori sono stati dotati di una serie "Loop" laterali in modo da essere appesi con stabilità e facilità ai reggiseccchi

*The Varano has the same features than the Varano w/cover version, these feeders have a series "of side loops" in such a way they could be stably and easily hanged through the bucket holders.*

CODE	SIZE
BOXEVA22	Ø32cm - H.18cm
BOXEVA23	Ø38cm - H.21cm



# PVC MATERIAL

## CEFALO CEFALO W/MESH

Questa linea di pratici secchi porta vivo in PVC, si è rivelata molto valida e funzionale. Il contenitore standard, ha una tasca laterale per l'ossigenatore a pile ed un coperchio trasparente con cerniera, mentre quello con rete, ha questa soluzione collocata proprio sotto il coperchio trasparente, la quale impedisce totalmente al vivo di fuoriuscire. Il colore giallo di questi secchielli, è stato scelto appositamente per una più rapida individuazione delle esche vive all'interno del contenitore stesso.

*This range of practical live bait buckets in PVC has proved to be extremely valid and practical. The standard container has a side pocket for the battery-operated oxygenator and a transparent lid with zipper, whereas the mesh version features a mesh placed just beneath the plastic lid, as a total guarantee that the live bait cannot get out. The colour yellow was chosen specifically for these accessories to make it easier to identify the live bait inside the container.*

24  
027  
cm

CODE: BOXEVA02



23  
033  
cm

CODE: BOXEVA03

## ACQUARIO

La borsa ACQUARIO proposta in due misure, è completamente stagna e il suo compito primario è quello di contenere il pescato, senza che questo vada a sporcare l'imbarcazione e senza che nessuno possa vedere il contenuto della borsa stessa, al momento dello sbarco... Utile anche a contenere indumenti e sfivaleria ancora umidi, da far asciugare con calma al momento del rientro a casa.

*The ACQUARIO comes in two sizes and is completely watertight, its primary function being to hold the catch, and prevent the fish from dirtying the boat (and also preventing anyone from seeing the contents of the bag during the landing phase). It is also perfect for holding clothes and boots that are still wet, which you can then dry out at leisure once you're back home.*

NEW 2018

63  
160  
cm

CODE: BOXEVA12

SOLD OUT

50  
110  
cm

CODE: BOXEVA13A



## WEPER X8

Weper X8 rappresenta la massima espressione nel campo dei trecciati. La geometria di trecciatura (HD ROUND SHAPE) e il mix di polimeri di resinatura (HT POLY MIX), massimizzano ed esaltano le proprietà fisico-chimiche di questa nuova fibra dalle caratteristiche straordinarie. L'HIGH-GRADE PE, evoluzione tecnica del PE, trasforma l'azione di pesca in un'esperienza unica. Il profilo rotondo e la mano liscia e setosa (SILK TECHNOLOGY) garantiscono lanci più lunghi mentre il processo di stiratura HPT ad alta pressione e temperatura, orienta le molecole della fibra incrementando del 20% il carico di rottura e spingendo il rapporto diametro/carico (DC-RATIO) a livelli prima impensabili. I trattamenti di finissaggio in MICROWAX creano una barriera protettiva che fa scivolare la treccia sugli ostacoli riducendo le rotture per abrasione e contribuendo a raddoppiare la vita del prodotto.

*Weper X8 is the latest technologies expression in the braided lines market. The braiding geometry (HD ROUND SHAPE) and the mix of resin polymers (HT POLY MIX) will maximize and exalt the physical and chemical features of this new extraordinary fiber. The HIGH GRADE PE, the technical evolution of the PE, will transform the fishing action in a unique experience. The round shape and the new silky coating (SILK TECHNOLOGY) will guarantee longer casts, the high pressure and temperature HTP pre stretching treatment will orientate the fibers molecules increasing the knot strenght of 20% and pushing the DC-RATIO diameters/strength ratio at a level never achieved before. The MICROWAX finishing permeating the braid will protect it from abrasions and will help it to slide on obstacles and snags increasing the braid life.*

## GREY

CODE 100yds	LBS	MM	kg	PE
NYWEX8115	15	0,09	7	0,35
NYWEX8121	21	0,125	9,5	0,60

CODE 150yds	LBS	MM	kg	PE
NYWEX8215	15	0,09	7	0,35
NYWEX8221	21	0,125	9,5	0,60
NYWEX8225	25	0,16	11,4	1,00
NYWEX8230	30	0,20	13,6	1,50
NYWEX8240	40	0,25	18,2	2,30
NYWEX8250	50	0,30	22,7	3,40
NYWEX8265	65	0,35	29,5	4,50
NYWEX8280	80	0,40	36,3	6,00

CODE 300yds	LBS	MM	kg	PE
NYWEX8315	15	0,09	7	0,35
NYWEX8321	21	0,125	9,5	0,60
NYWEX8325	25	0,16	11,4	1,00
NYWEX8330	30	0,20	13,6	1,50
NYWEX8340	40	0,25	18,2	2,30
NYWEX8350	50	0,30	22,7	3,40
NYWEX8365	65	0,35	29,5	4,50
NYWEX8380	80	0,40	36,3	6,00

## ORANGE

CODE 150yds	LBS	MM	kg	PE
NYWEX8415	15	0,09	7	0,35
NYWEX8421	21	0,125	9,5	0,60
NYWEX8425	25	0,16	11,4	1,00
NYWEX8430	30	0,20	13,6	1,50
NYWEX8440	40	0,25	18,2	2,30
NYWEX8450	50	0,30	22,7	3,40
NYWEX8465	65	0,35	29,5	4,50
NYWEX8480	80	0,40	36,3	6,00

CODE 300yds	LBS	MM	kg	PE
NYWEX8521	21	0,125	9,5	0,60
NYWEX8525	25	0,16	11,4	1,00
NYWEX8530	30	0,20	13,6	1,50
NYWEX8540	40	0,25	18,2	2,30
NYWEX8550	50	0,30	22,7	3,40
NYWEX8565	65	0,35	29,5	4,50
NYWEX8580	80	0,40	36,3	6,00



# BRAIDED LINE

FILI-LINES



## WEPER X4

Weper X4 è un tracciato All Round ad alto profilo tecnico, sviluppato per tutte le tecniche di pesca offre un ampio range di diametri. La geometria di trecciatura (HD ROUND SHAPE) e il mix di polimeri di resinatura (HT POLYMIX), massimizzano ed esaltano le proprietà fisico-chimiche di questa nuova fibra dalle caratteristiche straordinarie. L'HIGH-GRADE PE, evoluzione tecnica del PE, trasforma l'azione di pesca in un'esperienza unica. I trattamenti di finissaggio in MICROWAX creano una barriera protettiva che fa scivolare la treccia sugli ostacoli riducendo drasticamente le rotture per abrasione e contribuendo a raddoppiare la vita del prodotto. Il processo di stiratura HPT ad alta pressione e temperatura, orienta le molecole della fibra incrementando del 20% il carico di rottura, spingendo il DC-RATIO (rapporto diametro/carico) a livelli prima impensabili.

*Weper X4 is a high technical profile braided line suitable for many different kinds of fishing techniques and available in a big range of diameters. The braiding geometry (HD ROUND SHAPE) and the mix of resin polymers (HT POLYMIX) will maximize and exalt the physical and chemical features of this new extraordinary fiber. The HIGH GRADE PE, the technical evolution of the PE, will transform the fishing action in a unique experience. The MICROWAX finishing permeating the braid will protect it from abrasions and will help it to slide on obstacles and snags increasing the braid life. The high pressure and temperature HTP pre stretching treatment will orientate the fibers molecules increasing the knot strength of 20% and pushing the DC-RATIO to diameter/strength ratio never reached before.*

## GREY

CODE 100yds	LBS	MM	kg	PE
NYWEX4105	5	0,04	2,3	0,05
NYWEX4107	7	0,05	3,2	0,10
NYWEX4110	10	0,06	4,5	0,15
NYWEX4112	12	0,08	5,4	0,20
NYWEX4116	16	0,10	7,2	0,40

CODE 150yds	LBS	MM	kg	PE
NYWEX4210	10	0,06	4,5	0,15
NYWEX4212	12	0,08	5,4	0,20
NYWEX4216	16	0,10	7,2	0,40
NYWEX4220	20	0,125	9	0,60
NYWEX4225	25	0,16	10,5	1,00
NYWEX4233	33	0,20	15	1,50
NYWEX4245	45	0,25	20,4	2,30
NYWEX4260	60	0,35	27,2	4,50
NYWEX4280	80	0,45	36,3	7,50
NYWEX4299	100	0,55	45,5	11,00

CODE 300yds	LBS	MM	kg	PE
NYWEX4316	16	0,10	7,2	0,40
NYWEX4320	20	0,125	9	0,60
NYWEX4325	25	0,16	10,5	1,00
NYWEX4333	33	0,20	15	1,50
NYWEX4345	45	0,25	20,4	2,30
NYWEX4360	60	0,35	27,2	4,50
NYWEX4380	80	0,45	36,3	7,50
NYWEX4399	100	0,55	45,5	11,00

## ORANGE

CODE 150yds	LBS	MM	kg	PE
NYWEX4407	7	0,05	3,2	0,10
NYWEX4410	10	0,06	4,5	0,15
NYWEX4412	12	0,08	5,4	0,20
NYWEX4416	16	0,10	7,2	0,40
NYWEX4420	20	0,125	9	0,60
NYWEX4425	25	0,16	10,5	1,00
NYWEX4433	33	0,20	15	1,50
NYWEX4445	45	0,25	20,4	2,30
NYWEX4460	60	0,35	27,2	4,50
NYWEX4480	80	0,45	36,3	7,50
NYWEX4499	100	0,55	45,5	11,00

CODE 300yds	LBS	MM	kg	PE
NYWEX4516	16	0,10	7,2	0,40
NYWEX4520	20	0,125	9	0,60
NYWEX4525	25	0,16	10,5	1,00
NYWEX4533	33	0,20	15	1,50
NYWEX4545	45	0,25	20,4	2,30
NYWEX4560	60	0,35	27,2	4,50
NYWEX4580	80	0,45	36,3	7,50
NYWEX4599	100	0,55	45,5	11,00

CODE 1000yds	LBS	MM	kg	PE
NYWEX4660	60	0,35	27,2	4,50
NYWEX4680	80	0,45	36,3	7,50
NYWEX4699	100	0,55	45,5	11,00

## VASTAR

Il Vastar è il trecciato HI-TECH con il diametro più sottile e la resistenza più elevata al mondo. E' realizzato utilizzando il 100% di filato Spectra Honeywell (made in USA) e innovativi processi produttivi, studiati e realizzati in Italia. Il risultato di questa combinazione di tecnologie è un trecciato che ha il più sottile diametro e la più alta tenuta lineare di qualsiasi altro prodotto similare, presente oggi sul mercato. Viene prodotto in due colorazioni (verde e rosso), utili all'impiego nelle più varie discipline di pesca, sia in acque interne che in mare. Vastar è l'unico braided che certifica e garantisce il reale carico di rottura, il diametro ed i processi di lavorazione: ogni confezione include tale certificazione di garanzia.

*Vastar: the world's finest-diameter, high-resistance HI-TECH braided line. Made from 100% Spectra Honeywell (American-made) fiber by innovative manufacturing processes developed and implemented in Italy. The result of this combination of technologies is a braided line with the smallest diameter and the highest strength of any of the similar products now available on the market. Available in two colors (green and red) for use in the most varied specialties both in fish and salt waters. Vastar is the only braided line that certifies and guarantees its actual breaking strength, diameter, and the manufacturing processes: each package includes a warranty certificate.*

# VASTAR



CODE 150yds	LBS	MM
NYVARO15150	15	0,100
NYVARO20150	20	0,150
NYVARO25150	25	0,190
NYVARO30150	30	0,230

CODE 300yds	LBS	MM
NYVARO15300	15	0,100
NYVARO20300	20	0,150
NYVARO25300	25	0,190
NYVARO30300	30	0,230
NYVARO40300	40	0,270
NYVARO50300	50	0,330

CODE 600yds	LBS	MM
NYVARO40600	40	0,270
NYVARO50600	50	0,330

CODE 1000yds	LBS	MM
NYVARO51100	50	0,330
NYVARO60100	60	0,390
NYVARO80100	80	0,450
NYVAROX10100	100	0,510

# BRAIDED LINE

# VASTAR

CODE 150yds	LBS	MM
NYVAVE15150	15	0,100
NYVAVE20150	20	0,150
NYVAVE25150	25	0,190
NYVAVE30150	30	0,230
NYVAVE40150	40	0,270

CODE 300yds	LBS	MM
NYVAVE20300	20	0,150
NYVAVE25300	25	0,190
NYVAVE30300	30	0,230
NYVAVE40300	40	0,270

CODE 600yds	LBS	MM
NYVAVE30600	30	0,230
NYVAVE40600	40	0,270
NYVAVE50600	50	0,330



# KUREHA CHEMICALS

## MADE IN JAPAN

### ZAYO

Filo da finale adatto alla pesca in mare e in acqua dolce. Tutte le misure disponibili possiedono le caratteristiche che solo KUREHA è in grado di dare: morbidezza, assenza di memoria, assenza di torsione, eccezionale tenuta sul nodo, estrema resistenza all'abrasione e invisibilità. ZAYO da oggi diviene sinonimo di qualità impareggiabile.

*Hook length for fishing in salt and fresh water. All available measures have the characteristics that Kureha only is able to give: smoothness, absence of memory, absence of torsion, exceptional resistance to the knot and to abrasion and invisibility. Zayo is now synonymous with quality.*

CODE 50mt	CODE 30mt	Diameter (mm)	KG
NYZA16		0,165	2,95
NYZA18		0,185	3,40
NYZA20		0,200	4,40
NYZA22		0,225	5,70
NYZA25		0,255	6,90
NYZA28		0,285	8,00
NYZA32		0,325	9,80
NYZA36		0,360	12,30
NYZA40		0,400	13,50
NYZA43		0,435	15,00
NYZA47		0,470	18,00
NYZA52		0,520	22,00
	NYZA62	0,620	28,00
	NYZA74	0,740	35,00

### KUREHA CHEMICALS

L'avvento del Fluorocarbon ha davvero generato una nuova mentalità nel pescatore moderno, inducendo ad un sempre più ampio utilizzo di questo tipo di prodotti. Da oltre trent'anni l'azienda giapponese KUREHA CHEMICALS, leader nella produzione specifica Fluorocarbon Seguar, studia e si rinnova costantemente grazie all'ausilio di un pool di esperti e di nuove tecnologie sempre all'avanguardia, offrendo al mercato prodotti qualitativamente unici nel suo genere.

*The introduction of fluorocarbon generated a new mentality in the modern angler, with the result that this type of product is now used on an extremely broad scale. For more than thirty years, the Japanese KUREHA CHEMICALS company, leader in manufacture of specific fluorocarbons, has been constantly researching and improving its products, thanks to a pool of experts and new technologies that are always at the avant-garde. The result is an offer of products unique in their genre as to quality.*

### KING

Le tre caratteristiche principali del KING sono l'eccezionale tenuta sul nodo, l'estrema resistenza all'abrasione e invisibilità che solo il fluorocarbon 100% KUREHA è in grado di donarci. Il fluorocarbon KING è la dimostrazione che i diametri sottili possono permettere prestazioni prima inimmaginabili. Questo fluorocarbon da finale è il frutto della collaborazione tra COLMIC e KUREHA azienda leader nella produzione di fluorocarbon.

*The three main characteristics of KING are the exceptional resistance to the knot, to abrasion and invisibility that only 100% fluorocarbon KUREHA is able to ensure. This hook length fluorocarbon is the result of cooperation between COLMIC and Kureha, leader in the production of fluorocarbon.*

CODE 50mt	Diameter (mm)	KG
NYK110	0,100	1,20
NYK111	0,115	1,40
NYK112	0,128	1,82
NYK114	0,148	2,35
NYK116	0,165	2,85
NYK118	0,180	3,30
NYK120	0,200	4,30
NYK122	0,225	5,50
NYK126	0,250	6,70

# FLUOROCARBON

FILI-LINES

## WIND

La collaborazione con una delle maggiori industrie giapponesi ha permesso di sviluppare appositamente per noi un Fluorocarbon dalle ottime caratteristiche tecniche in una gamma molto estesa di diametri, specialmente nei diametri alti. Il tutto ad un rapporto qualità prezzo veramente eccezionale.

*The partnership with a major Japanese industry has enabled us to develop a Fluorocarbon with excellent technical characteristics in a very wide range of diameters, especially the high ones. This has an excellent price/quality ratio.*

CODE 50mt	Diameter (mm)	KG
NYWIN16	0,165	2,60
NYWIN18	0,185	3,20
NYWIN20	0,200	3,80
NYWIN22	0,220	4,60
NYWIN25	0,250	5,50
NYWIN28	0,280	6,70
NYWIN30	0,310	7,50
NYWIN35	0,350	9,70
NYWIN40	0,409	12,50
NYWIN46	0,460	14,90
NYWIN52	0,520	18,50
NYWIN57	0,570	21,60
NYWIN62	0,620	24,90
NYWIN71	0,710	29,00

## SHADE

Questo polimero in fluorocarbon 100% è dotato di una grande resistenza alla trazione e di una morbidezza eccellente, grazie alla quale si ottiene la più naturale presentazione dell'esca.

*This 100% fluorocarbon polymer features high resistance to traction and great suppleness, which permits to obtaining truly "natural" bait presentation.*

CODE 50mt	Diameter (mm)	KG
NYSH12	0,120	1,75
NYSH14	0,140	2,05
NYSH16	0,160	2,90
NYSH18	0,180	3,35
NYSH20	0,200	3,90



## RIVERGE

Realizzato con il particolare processo S.C.C., il quale dona al monofilo un'incredibile morbidezza, il RIVERGE è l'ideale per la pesca in mare e in acque interne.

*Manufactured by the SCC process, which lends the monofilament an incredible suppleness, RIVERGE is ideal for fishing in sea and inland waters.*

### COLPO

CODE 50mt	Diameter (mm)	KG
NYRIC065	0,065	0,45
NYRIC071	0,071	0,52
NYRIC080	0,080	0,61
NYRIC088	0,088	0,73
NYRIC096	0,096	0,95
NYRIC112	0,112	1,35
NYRIC125	0,125	1,75
NYRIC135	0,135	2,20
NYRIC152	0,152	2,80

# Seaguar

### TROTA

CODE 50mt	Diameter (mm)	KG
NYRIT148	0,148	2,20
NYRIT165	0,165	2,70
NYRIT185	0,185	3,20
NYRIT205	0,205	4,20

# Seaguar



**20% ELONGATION**



**25% ELONGATION**



**22% ELONGATION**

## ACE

Monofilo con un grado di rifrazione più basso del 80%, rispetto a qualsiasi altro nylon tradizionale. Molto resistente, mantiene invariato il carico di rottura anche dopo un lungo periodo in acqua.

*A monofilament with a refraction coefficient 60% lower than any other traditional nylon. Great resistance and a breaking strength that remains unchanged even after long periods in the water.*

CODE 50mt	Diameter (mm)	LBS	KG
NYSE165	0,165	5,5	2,5
NYSE185	0,185	6,6	3,0
NYSE205	0,205	8,8	4,0
NYSE235	0,235	11,6	5,3
NYSE260	0,260	13,6	6,3
NYSE285	0,285	15,4	7,0
NYSE330	0,330	19,14	8,7
NYSE370	0,370	23,5	10,7
NYSE405	0,405	25,5	11,6
NYSE435	0,435	30,0	13,4
NYSE470	0,470	35,0	15,6
NYSE520	0,520	44,0	20,0
NYSE620	0,620	52,8	25,0
NYSE740	0,740	60,0	30,0
NYSE800	0,800	80,0	36,5
NYSE910	0,910	95,0	43,0

## Seaguar

## SOFT

Questo monofilo affianca il SEAGUAR ACE e si differenzia da esso solo per una maggiore morbidezza, consentendo una presentazione dell'esca molto più naturale.

*This 100% fluorocarbon monofilament flanks the SEAGUAR ACE, from which it differs only in softness granting a much more natural presentation of the bait.*

CODE 50mt	Diameter (mm)	LBS	KG
NYSF016	0,165	6,6	3,0
NYSF018	0,185	7,7	3,5
NYSF020	0,205	9,9	4,5
NYSF023	0,235	13,2	6,0
NYSF026	0,260	15,4	7,0
NYSE028	0,285	17,6	8,0
NYSF033	0,330	22,0	10,0
NYSF037	0,370	26,4	12,0
NYSF040	0,405	28,6	13,0
NYSF043	0,435	33,0	15,0
NYSF047	0,470	37,4	17,0
NYSF052	0,520	48,4	22,0
NYSF057	0,570	54,0	24,5

## Seaguar

## FXR

Rivoluzionario fluorocarbon che migliora le già eccellenti caratteristiche tecniche della gamma SEAGUAR. Maggiore morbidezza, leggerezza e resistenza grazie all'avanzata tecnologia utilizzata per il suo sviluppo.

*It is a revolutionary monofilament that improves on the already excellent characteristics of the SEAGUAR family. An extraordinary suppleness, absolutely comparable to that of a classic nylon.*

CODE 50mt	Diameter (mm)	KG
NYSFXR016	0,165	3,2
NYSFXR018	0,185	4,0
NYSFXR020	0,205	5,2
NYSFXR021	0,218	6,1
NYSFXR023	0,230	6,9
NYSFXR026	0,260	8,1
NYSFXR028	0,280	9,7
NYSFXR033	0,330	11,3
NYSFXR037	0,370	13,9
NYSFXR040	0,400	15,1

CODE 50mt	Diameter (mm)	KG
NYSFXR043	0,430	17,4
NYSFXR047	0,470	20,3
NYSFXR052	0,520	26,0
NYSFXR057	0,570	28,6
NYSFXR062	0,620	31,2
NYSFXR066	0,660	36,5
NYSFXR070	0,700	38,6
NYSFXR074	0,740	41,8

# FLUOROCARBON

FILI-LINES

## PINK LABEL

Monofilo innovativo in casa Seaguar. Grazie a delle esclusive resine oltre ad essere più morbido ad avere una maggiore resistenza all'abrasione ed minimo allungamento, l'esclusivo colore rosa lo rende ancora più invisibile grazie al bassissimo grado di refrazione. Una parte del ricavato della vendita di questo monofilo, Seaguar lo devolve alla lotta contro il cancro.

CODE 50mt	Diameter (mm)	LBS	KG
NYSEP015	0,330	24	10,7
NYSEP020	0,405	32	14,7
NYSEP025	0,435	37	17,2
NYSEP030	0,520	55	24,9
NYSEP040	0,620	69	31,0
NYSEP050	0,660	79	35,5
NYSEP060	0,740	90	40,5
NYSEP080	0,810	105	48,0
NYSEP100	0,910	130	59,0

*Innovative monofilament. Thanks to its exclusive resins, it's softer but able to support a bigger resistance against abrasions and a minimum extension. Its exclusive color pink makes it much more invisible, thanks to its low refraction level. A part of the Seaguar's sale proceeds will be devolved to the foundation against cancer.*

# Seaguar



## BIG GAME

Premier Big Game ha diametri inferiori e maggiore tenuta rispetto al tradizionale Big Game. Offre una incredibile forza al nodo ed una memoria molto bassa pur essendo un fluorocarbon molto morbido. E' ideale per grosse prede, sia in acque interne che salate.

CODE 15mt	Diameter (mm)	LBS
NYSFP081	0,81	85
NYSFP091	0,91	100
NYSFP105	1,05	130
NYSFP117	1,17	150
NYSFP128	1,28	170
NYSFP138	1,38	200

*Fluoro Premier has smaller diameters and increased strength vs. our traditional Big Game line. Fluoro Premier offers incredible knot and tensile strength and is an extremely soft line with low memory. Ideal for larger species in fresh or salt water. As with all 100% Fluorocarbon products, Fluoro Premier Leader is invisible underwater and to fish.*



## WIND ON

Queste linee da 7.62 mt già pronte all'uso, sono caratterizzate da un filo trecciato con anima cava e asole, giuntato su un terminale SEAGUAR FLUOROCARBON FLUORO PREMIERE. Il tutto può essere unito alla lenza madre, tramite un semplice collegamento asola con asola evitando qualsiasi tipo di nodo.

CODE 7,62mt	Diameter (mm)	LBS
NYSW0062	0,62	55
NYSW0074	0,74	70
NYSW0081	0,81	85
NYSW0091	0,91	100
NYSW105	1,05	125
NYSW117	1,17	150
NYSW128	1,28	175
NYSW138	1,38	200

*These 7.62m lengths are ready to use: a braided dyneema line with a hollow core and loops, joined to a SEAGUAR FLUOROCARBON FLUORO PREMIERE leader. The leader assembly can be joined to the mainline via simple loop-to-loop tying.*

# NXGEN FLUOTEC

L'azienda fiorentina, leader in Italia e in Europa desidera presentare la svolta nella produzione di monofili, il NXGEN FLUOTEC. Consapevole del potenziale di questo polimero, COLMIC ha deciso di mettere in campo la propria esperienza e le consulenze dei migliori pescatori di ogni specialità al fine di sviluppare fili specifici per rispondere alle più varie necessità. Il risultato di questo incontro tra innovazione ed esperienza è una nuova generazione di monofili. Da ciò deriva la seconda parte del nome FLUOTEC, tecnologia simile al fluorocarbon. Questo non significa che si tratti solo di fili rigidi, infatti la caratteristica principale di questo polimero è quella di potersi combinare con tutti gli elementi usati nella produzione di monofili, così da poterne assumere ed esaltare le caratteristiche. Quindi avremo fili rigidi e quasi privi di allungamento laddove siano necessari, ma anche morbidi, o con qualsiasi caratteristica specifica richiesta dalla tecnica che si intende praticare. Grazie a campioni come Jacopo Falsini, Franco Mancini, Maurizio Pastacaldi e tutti i collaboratori di Colmic impegnati nelle competizioni nazionali e internazionali, sono state sviluppate 3 linee che hanno in comune il principio NXGEN FLUOTEC: NX - AT70 - PT50

*The Florentine company, a leader in Italy and in Europe wishes to announce a breakthrough in the development of monofilaments. Aware of the potential of this polymer COLMIC decided to field its own experience and the advice of the best fishermen in each speciality in order to develop specialist lines that correspond to the various specific needs of anglers. The result of this fusion between innovation and experience is a new generation of monofilaments which leads to the second part of the name FLUOTEC, a technology similar to that of fluorocarbon. This does not mean only strong lines, in fact, the main feature of this polymer is its ability able to combine with all the elements used in the production of monofilaments, so that all the characteristics can be maximized. Then we will have strong lines which are and almost devoid of elongation but also soft and elastic, or with any specific feature request by the angler that you wish to produce. With champion anglers as Jacopo Falsini, Franco Mancini, Maurizio Pastacaldi and all the staff of Colmic involved in national and international competitions, we have developed 3 lines that have in common the principle of NXGEN FLUOTEC: NX - AT70 - PT50*

## NX 80

La top class della pesca. Offre il massimo della resistenza a trazione ed abrasione, oltre ad avere una bassa percentuale di allungamento (27%). Siamo davanti all'ultimo frutto dell'esperienza COLMIC nel match fishing. Un filo con poca elasticità, una perfetta tenuta in bobina, e una resistenza all'abrasione impareggiabile. Provate a stringere un piombo su un filo NX80 e a farlo scorrere più volte sulla lenza. Il risultato vi lascerà sbalorditi, l'abrasione sarà minima, o addirittura inesistente.

*Is top class for coarse fishing and all the lines which are used on the reel. The main line for match anglers and the most important competitions. Provides the ultimate in tensile strength and abrasion resistance. What we have before us is the result all the experience in match fishing of COLMIC. A line with the right amount of stretch, perfect on the reels line and, and unparalleled abrasion resistance. Squeeze a lead on the line NX80 and slide it up and down several times, the result will leave you stunned, abrasion will be minimal or non-existent, incredible.*

## NX 50

Fili dotati di caratteristiche simili alla serie NX80 e adatti per essere usati in tutte le pesche in cui c'è bisogno una perfetta tenuta in bobina, e resistenza all'abrasione.

*All the best characteristics of the series NX of lines suitable for all types of fishing in which there is a need for perfect coiling of the reel line for casting and a high abrasion resistance.*

## NX 30

Un filo NX all round che permette di avere una lenza madre di qualità con un prezzo altamente concorrenziale.

*An NX standard line which all round abilities at a highly competitive price.*

## AT 70

Questi monofili sono caratterizzati da bassissima percentuale di allungamento, 16%, contrassegnati da una banda rossa con la scritta N°1 VERY LOW STRETCH 16% sulla bobina. Tale percentuale di allungamento, è la metà di quella dei nylon tradizionali e minore di quella del fluorocarbon. Ciò significa che in trazione al massimo del carico di rottura questi fili si allungano del 16%, ovviamente con carichi inferiori anche l'allungamento sarà minore. Tale caratteristica sarà molto apprezzata dai pescatori che necessitano di lenze che trasmettano ogni vibrazione e che permettano ferrate a lunghe distanze. Questi fili di fatto hanno messo la parola fine sul binomio poca elasticità/molta memoria, poiché risultano poco elastici ma sempre morbidi e fluidi. Inoltre, gli AT70 sono anche resistentissimi sul nodo e all'abrasione.

*These monofilaments are characterized by their very low elongation percentage, 16%, and are identified with the red band with the inscription N°1 VERY LOW stretch 16% on the spool. This elongation percentage, lower than that of fluorocarbon (20% - 30%) and approximates to that of the even braided line This means that in tension at the maximum breaking strength these lines stretch about 16%, but under lower loads the elongation will be much lower. This feature will be very popular with fishermen who have to make long casts and require lines that transmit every sensation and allow striking at long distances. These lines have in fact put an end to the correlation between the lack of elasticity and a lot of memory, because they are not very elastic but are still soft and fluid. Furthermore, the AT70 is also very resistant to abrasion and as has a high knot strength on the knot. Is not by chance that the lines AT70 are N° 1 VERY LOW stretch.*

## PT 70

La serie di fili nata per le pesche dove le lenze low stretch, ossia caratterizzate da bassa percentuale di allungamento, devono avere anche alta visibilità. Monofili necessari nel surf Casting e in tutte le discipline in cui si pesca in notturna, o in condizioni di scarsa visibilità. La gamma è composta di fili con colore in pasta dotati di tutte le caratteristiche migliori del polimero NXGEN: morbidezza e fluidità, resistenza a trazione ed abrasione e pochissima elasticità. Tutti i monofili derivati dalla combinazione del NXGEN FLUOTEC sono contraddistinti da questo marchio e vengono imbobinati a spire parallele a seguito di un processo di stiratura. Questi procedimenti, effettuati in Italia, sono atti ad eliminare la memoria e garantire un caricamento corretto dei nylon su mulinelli a bobina fissa e rotante, esaltandone le eccezionali caratteristiche. Inoltre, il blister che costituisce la confezione protegge prodotti già molto resistenti dal deterioramento. Siamo davanti ad un polimero che ha permesso e permetterà a Colmic di produrre monofili di altissima qualità adatti a coprire tutte le necessità dei pescatori in tutte le fasce di mercato.

*This series of lines created for fishing where low stretch and high visibility is required. Surf Casting and all types in which you are fishing at night or in poor visibility. The range consists of colored line with all the best features of the polymer NXGEN: fluidity, toughness and strength, tensile strength and abrasion resistance all with nd very little elasticity. All monofilaments derived from the combination of NXGEN FLUOTEC are indicated by this name, all the lines are spools in perfect parallel coils, these procedures are carried out in Italy and are designed to eliminate any memory and ensure proper loading of the nylon on angler's reels, thus enhancing the NXGEN's exceptional features. Furthermore, the blister packaging further protects the products already resistant features against deterioration. We now have a polymer that has allowed Colmic to produce a super high quality monofilament which covers all the needs of the fishermen in all market segments.*



## STEEL RESISTANCE

Il non plus ultra della combinazione tra qualità e versatilità, senza compromessi. Il NXGEN FLUOTEC combinato a materiali di indiscussa qualità donano a questo caratteristiche eccellenti. Resistenza sul nodo e all'abrasione; assenza di memoria. Questo filo sarà ottimo sia per essere imbobinato, sia per tutti gli usi in cui avere il top della qualità sia la necessità imprescindibile.

*This is the ultimate combination of versatility and quality without compromise. The NXGEN FLUOTEC compounded with quality materials offers these acknowledged features. Knot strength resistance, abrasion resistance, and lack of memory. This line is a perfect reel line, and for any use where top quality attributes are required.*

CODE 150mt	CODE 300mt	Diameter (mm)	KG
NYST15012		0,12	2,30
NYST15014	NYST30014	0,14	3,00
NYST15016	NYST30016	0,16	3,80
NYST15018	NYST30018	0,18	4,90
NYST15020	NYST30020	0,20	6,00
NYST15022	NYST30022	0,22	7,40
NYST15025	NYST30025	0,25	8,90
NYST15030	NYST30030	0,30	14,9
NYST15035	NYST30035	0,35	16,5
NYST15040	NYST30040	0,40	21,0



## NX80

### SPECIAL REEL

HIGH KNOT RESISTANCE - WATER REPELLENT - LOW STRETCH - U.V. PROTECTION TRIPLE TREATMENT - ABRASION RESISTANCE - SUPER STRONG HIGH RESISTANCE



## NX50

### SPECIAL REEL

HIGH KNOT RESISTANCE - WATER REPELLENT - LOW STRETCH - U.V. PROTECTION TRIPLE TREATMENT ABRASION RESISTANCE - SUPER STRONG HIGH RESISTANCE - ANTI TWIST

## ASTOR

Le migliori caratteristiche di resistenza e qualità in un monofilo dal costo accessibile. ASTOR è il filo che i campioni vogliono al prezzo che tutti i pescatori vorrebbero.

*Excellent resistance and improved quality at an affordable price. Astor is the line desired by Champions at a price all fisherman desire.*

CODE 200mt	Diameter (mm)	KG
NYAS0128	0,128	2,05
NYAS0148	0,148	2,60
NYAS0168	0,168	3,40
NYAS0188	0,188	4,40
NYAS0208	0,208	5,80
NYAS0250	0,250	7,70
NYAS0300	0,300	10,90
NYAS0350	0,350	14,10
NYAS0400	0,400	17,50
NYAS0450	0,450	21,30
NYAS0500	0,500	25,50

## ALL ROUND

Come dice il nome stesso, si tratta di un filo capace di essere un alleato formidabile in ogni situazione. Ottimo, sia per essere imbobinato sul mulinello, sia per essere impiegato sulla canna fissa.

*As the name suggests, this nylon is an invaluable ally in any situation. Excellent, it can be used as reel line, or as a pole line.*

CODE 150mt	CODE 300mt	Diameter (mm)	KG
NYAL150115		0,115	1,55
NYAL150129	NYAL300129	0,129	2,10
NYAL150149	NYAL300149	0,149	2,75
NYAL150169	NYAL300169	0,169	3,50
NYAL150189	NYAL300189	0,189	4,50
NYAL150210	NYAL300210	0,210	5,90
NYAL150250	NYAL300250	0,250	7,90
NYAL150300	NYAL300300	0,300	11,30
NYAL150350	NYAL300350	0,350	14,70
NYAL150400	NYAL300400	0,400	18,90
NYAL150450		0,450	23,90
NYAL150500		0,500	28,90



## NX50

### TOTAL FISHING

KNOT RESISTANCE - WATER REPELLENT - ANTI TWIST - U.V. PROTECTION TRIPLE TREATMENT ABRASION RESISTANCE - EXTRA STRONG



## NX30

### ALL FISHING

HIGH KNOT RESISTANCE - WATER REPELLENT - ANTI TWIST - U.V. PROTECTION  
TRIPLE TREATMENT - ABRASION RESISTANCE - EXTRA STRONG

### PROJECT 360

Adatto ad ogni tipo di pesca in mare e in acqua dolce. Potrete imbobinarlo sul mulinello, o usarlo sulle canne fisse. Per chi ama avere il prodotto che copre la pesca a 360° ad un prezzo competitivo.

*Suitable for all types of fishing both in sea and in fresh water. You can spool it as a reel line or use it on with a pole. For those who love fishing at 360° at a competitive price.*

CODE 100mt	CODE 300mt	Diameter (mm)	KG
NYPR10014		0,140	2,10
NYPR10016		0,160	2,65
NYPR10018	NYPR30018	0,180	3,40
NYPR10020	NYPR30020	0,200	4,20
NYPR10022	NYPR30022	0,220	5,20
NYPR10025	NYPR30025	0,250	6,10
NYPR10030	NYPR30030	0,300	7,20
NYPR10035	NYPR30035	0,350	9,60
NYPR10040	NYPR30040	0,400	11,50
NYPR10045	NYPR30045	0,450	13,30
NYPR10050	NYPR30050	0,500	15,20

### F1 SPIDER

Il top line da usare come lenza madre nel match fishing, sviluppato da Jacopo Falsini e il Team Colmic per la competizione e commercializzato da Colmic per soddisfare le necessità dei pescatori più esigenti. Questo monofilo coniuga il polimero NXGEN con i materiali top quality usati nell'agonismo. Il risultato è il filo più indicato per match fishing e fishery.

*This premier line developed by Jacopo Falsini and the Colmic team is best used as a main line in match fishing. Designed for competition, it is marketed by Colmic in order to satisfy the most demanding of anglers. This monofilament combines the NXGEN polymer with top quality. The result being the most specific nylon for match fishing and commercial fisheries.*

CODE 100mt	Diameter (mm)	KG
NYSP097	0,097	1,30
NYSP116	0,116	1,95
NYSP135	0,135	2,53
NYSP152	0,152	3,35
NYSP168	0,168	4,05
NYSP188	0,188	5,20
NYSP209	0,209	6,20
NYSP229	0,229	7,50
NYSP259	0,259	8,90
NYSP300	0,300	11,50



## NX80

### SPECIAL FISHERY

HIGH KNOT RESISTANCE - WATER REPELLENT - LOW STRETCH - U.V. PROTECTION TRIPLE TREATMENT  
ABRASION RESISTANCE - SUPER STRONG HIGH RESISTANCE



## NX50

### SPECIAL REEL

HIGH KNOT RESISTANCE - WATER REPELLENT - LOW STRETCH  
U.V. PROTECTION TRIPLE TREATMENT - EXTRA STRONG - ABRASION RESISTANCE - ANTI TWIST

### STOR XX

La famiglia NX GEN si ingrandisce... È nato STORR XX... ideato per gli amanti della pesca allo storione e tutti i pesci di grandissima stazza. Ideale per il mulinello e per i finali questo monofilo di qualità elevata garantisce: una straordinaria tenuta al nodo, resistenza all'abrasione e una bassa memoria meccanica con una bassa percentuale di allungamento.

*The NX GEN family expands. The novelty is STORR XX. It's ideal for sturgeons' anglers and for all the big sized fishes. It's suitable for reel or as terminal line. This high quality monofilament warranties: an extraordinary knot strength, resistance to abrasion and a low memory combined with a low extension percentage.*

CODE 300mt	Diameter (mm)	KG
NYST5050	0,50	24,00
NYST5062	0,62	33,00
NYST5070	0,70	41,00
NYST5080	0,80	49,00

## FEEDER PRO

Un filo dotato di eccezionale morbidezza abbinata una bassissima percentuale di elasticità, N°1 VERY LOW STREACH 16%. Pensato ideato prendendo come punto di riferimento i migliori agonisti della specialità, risulta ottimo, sia in fase di lancio, sia durante la ferrata.

*A line created with exceptional softness combined with a very low elasticity percentage, N°1, VERY LOW STREACH (16%). Thought and care, and taking into account the requirements of top match fishermen has resulted in a Superior Nylon with all the characteristics of a braided line.*

CODE 250mt	Diameter (mm)	KG
NYFEP0168	0,168	3,70
NYFEP0188	0,188	4,50
NYFEP0208	0,208	5,90
NYFEP0230	0,230	7,30
NYFEP0260	0,260	8,90
NYFEP0300	0,300	10,70



**AT70**  
16% LOW STRETCH

## SPECIAL FEEDER

HIGH KNOT RESISTANCE - WATER REPELLENT - 16% LOW STRETCH  
U.V. PROTECTION TRIPLE TREATMENT - ABRASION RESISTANCE

## BLADE

Il monofilo che coniuga le caratteristiche della linea NXGEN con l'esperienza di campioni del calibro di Jacopo Falsini nella pesca all'inglese. Si tratta di un filo affondante dotato di altissima resistenza e di una bassissima percentuale di allungamento.

*This monofilament that combines the NXGEN series characteristics with the Champion calibre Match fishing experience of Jacopo Falsini. It is a sinking line with high resistance and a very low elongation percentage.*

CODE 150mt	Diameter (mm)	KG
NYBL0148	0,148	2,80
NYBL0168	0,168	3,60
NYBL0188	0,188	4,50
NYBL0210	0,210	5,90
NYBL0230	0,230	7,50



**AT70**  
16% LOW STRETCH

## SPECIAL SINKING

HIGH KNOT RESISTANCE - WATER REPELLENT - ANTI TWIST NO MEMORY - ABRASION RESISTANCE

## SPRAY LEADER

Spray Leader è il monofilo NXGEN ideato per essere impiegato come terminale nel big game, ma adatto per tutte le specialità di pesca in mare e acqua dolce. Resistenza all'abrasione, morbidezza, bassa elasticità, e grande tenuta sul nodo e sulla trazione sono le caratteristiche che permettono di impiegare questo fantastico Nylon nella traina, nel jiggging, nello spinning nella pesca al siluro, allo storione, alle carpe, etc... La speciale confezione ad astuccio circolare facilita il pescatore nel riporre e conservare il prodotto.

CODE 50mt	Diameter (mm)	KG	LBS
NYSP0149	0,149	2,80	6,20
NYSP0169	0,169	3,50	7,70
NYSP0189	0,189	4,50	10,00
NYSP0209	0,209	5,50	12,20
NYSP0230	0,230	6,60	14,60
NYSP0260	0,260	7,80	17,30
NYSP0300	0,300	9,10	20,00
NYSP0330	0,330	10,50	23,00
NYSP0360	0,360	11,80	26,00
NYSP0400	0,400	13,30	29,00
NYSP0450	0,450	15,70	34,00
NYSP0500	0,500	19,80	44,00
NYSP0550	0,550	23,00	51,00
NYSP0620	0,620	28,00	62,00
NYSP0720	0,720	33,00	73,00
NYSP0800	0,800	38,00	84,00
NYSP0900	0,900	45,00	100,00

*The Spray Leader is a NX Gen line monofilament expressly designed for hook lengths and shock leaders in big game fishing. Abrasion resistance, softness, low stretch, excellent knot strength are the main features of this line, making it perfectly suitable for trolling, jiggging and spinning. Conveniently packaged in a special large arbour spool.*



## LEADER LINE

NEW TECHNOGY PROCESS - KNOT RESISTANCE - WATER REPELLENT - 25% LOW STRETCH  
U.V. PROTECTION TRIPLE TREATMENT - ABRASION RESISTANCE



**AT70**  
16% LOW STRETCH



**BOLENTINO - LIGHTJIGGING - DRIFTING**

HIGH KNOT RESISTANCE - WATER REPELLENT - 16% LOW STRETCH  
U.V. PROTECTION TRIPLE TREATMENT - ABRASION RESISTANCE - ANTI TWIST



**STRIKE**

Il nome è già una garanzia di successo, d'altronde doveva essere all'altezza di un prodotto di sicuro successo. Lo STRIKE è stato creato appositamente per la pesca dalla barca grazie all'esperienza di Maurizio Pastacaldi e dei migliori capitani dei nostri mari. Le caratteristiche di questo polimero sono state scelte per rendere al meglio nel bolentino, nel light jogging e nel drifting. Anche questo filo oltre alle caratteristiche proprie di tutta la linea NXGEN possiede un bassissima percentuale di allungamento.

CODE 200mt	Diameter (mm)	KG
NYSTRI0215	0,215	5,50
NYSTRI0235	0,235	7,00
NYSTRI0260	0,260	8,50
NYSTRI0300	0,300	10,20
NYSTRI0350	0,350	14,00

*The name is already a warranty of success; and is already a "must have" product. The STRIKE line has been specifically designed for boat fishing following the experience of Maurizio Pastacaldi and other captains of our seas. The characteristics of this polymer have been chosen to offer the best in Bolentino, in light jogging and in drifting. In addition to the NXGEN characteristics this line also possesses a very low elongation percentage.*

**NX50**



**SPECIAL REEL**

HIGH KNOT RESISTANCE - WATER REPELLENT - LOW STRETCH  
U.V. PROTECTION TRIPLE TREATMENT - EXTRA STRONG - ABRASION RESISTANCE - ANTI TWIST



**KROME**

Il filo da bobina affidabile e resistente pensato per la pesca in mare. Polimero dotato di bassa percentuale di allungamento, e notevole resistenza sul nodo e all'abrasione.

CODE 150mt	CODE 300mt	Diameter (mm)	KG
NYKR150129		0,129	2,10
NYKR150149	NYKR300149	0,149	2,75
NYKR150169	NYKR300169	0,169	3,50
NYKR150189	NYKR300189	0,189	4,50
NYKR150209	NYKR300209	0,209	5,90
NYKR150229	NYKR300229	0,229	7,00
NYKR150259	NYKR300259	0,259	8,20
NYKR150300	NYKR300300	0,300	11,30
NYKR150350	NYKR300350	0,350	14,70
NYKR150400	NYKR300400	0,400	18,90
	NYKR300500	0,500	24,70

*The spool line is reliable and resistant. Designed for sea fishing. This Polymer has a low elongation percentage, knot strength and highly resistant to abrasion.*



**TROPHY SURF**

Ideato appositamente per il surf casting, permette ferrate sicure a lunga distanza grazie alla sua bassissima percentuale di allungamento.

*Purposely designed for surf casting, it permits safe catches at a long distances thanks to its very low elongation percentage.*

CODE 300mt	Diameter (mm)	KG
NYTRO14	0,140	2,80
NYTRO16	0,160	3,50
NYTRO18	0,180	4,50
NYTRO20	0,200	5,70
NYTRO22	0,220	6,90
NYTRO25	0,250	8,60
NYTRO28	0,280	10,20
NYTRO30	0,300	11,30
NYTRO33	0,330	14,00

**AT70**  
16% LOW STRETCH



**SPECIAL REEL**

HIGH KNOT RESISTANCE - WATER REPELLENT - 16% LOW STRETCH  
U.V. PROTECTION TRIPLE TREATMENT - ABRASION RESISTANCE - ANTI TWIST



**OMEGA**

Adatto ad ogni tipo di pesca in mare dove sono richiesti diametri non eccessivi ed alte resistenza. Molto indicato per essere caricato sul mulinello, risulta molto versatile adattandosi a molte delle specialità di cui la pesca in mare è composta.

*Suitable for any type of sea fishing where you need high resistance, but with fine diameters. Easy to load on the reel, it is very versatile, and easily adapts to many of the sea fishing specialties.*

CODE 300mt	Diameter (mm)	KG
NYOME014	0,140	2,20
NYOME016	0,160	2,80
NYOME018	0,180	3,70
NYOME020	0,200	4,80
NYOME022	0,220	6,00
NYOME025	0,250	7,40
NYOME030	0,300	9,90

**PT50**



**SPECIAL REEL**

HIGH KNOT RESISTANCE - WATER REPELLENT - ANTI TWIST  
U.V. PROTECTION TRIPLE TREATMENT - EXTRA STRONG - ABRASION RESISTANCE - LOW STRETCH



**IRIDE**

Adatto ad ogni tipo di pesca in mare dove sono richiesti diametri non eccessivi ed alte resistenza. Molto indicato per essere caricato sul mulinello, risulta molto versatile adattandosi a molte delle specialità di cui la pesca in mare è composta.

*Suitable for any type of sea fishing where you need high resistance, but with fine diameters. Easy to load on the reel, it is very versatile, and easily adapts to many of the sea fishing specialties.*

CODE 300mt	Diameter (mm)	KG
NYIRO14	0,140	2,20
NYIRO16	0,160	2,80
NYIRO18	0,180	3,70
NYIRO20	0,200	4,80
NYIRO22	0,220	6,00
NYIRO25	0,250	7,40
NYIRO30	0,300	9,90

**PT50**



**SPECIAL REEL**

HIGH KNOT RESISTANCE - WATER REPELLENT - ANTI TWIST  
U.V. PROTECTION TRIPLE TREATMENT - EXTRA STRONG - ABRASION RESISTANCE - LOW STRETCH



## X5000

L'X5000 è un monofilo clear, sottoposto ad un particolare trattamento "fluorine process" e si presta ad esser utilizzato nelle più svariate circostanze tecniche, e di pesca. Validissimo per il mulinello nello spinning, la bolognese, la trota lago ed il surfcasting, ma ottimo anche per la realizzazione di lenze per la pesca al colpo, per travi da surf casting e da bolentino. Un nylon universale, di qualità superiore.

CODE 150mt	CODE 600mt	Diameter (mm)	KG
NYX510	NYX5610	0,100	1,38
NYX512	NYX5612	0,120	2,29
NYX514	NYX5614	0,140	2,85
NYX516	NYX5616	0,160	3,98
NYX518	NYX5618	0,180	5,05
NYX520	NYX5620	0,200	6,20
NYX522	NYX5622	0,220	7,50
NYX525	NYX5625	0,250	9,00
NYX530	NYX5630	0,300	12,50

*The X5000 is a "clear" monofilament treated with the special "fluorine process" and is suitable for the most varied of technical circumstances and fishing styles. A great line on the reel for spinning, bolognese, lake trout, and surfcasting, but just as good for constructing lines for coarse fishing, for surfcasting, and for rod trolling. A superior-quality, universal nylon.*

## FORMER

Monofilo giapponese. Un doppio trattamento di siliconatura lo rende inattaccabile da agenti esterni, aumentandone la resistenza all'abrasione e la scorrevolezza. Il FORMER è particolarmente indicato per la pesca in passata con la bolognese, per la pesca della carpa, del siluro e per tutte le discipline di pesca in mare.

*Japanese monofilament. A double silicon treatment makes it untouchable by external agents and very easy-running while increasing its abrasion resistance. FORMER is particularly suitable for trotting with the bolognese rod, for carp and catfish fishing, and for all the sea-fishing specialties.*

CODE 150mt	CODE 600mt	CODE 2000mt	Diameter (mm)	KG
NYFO12		NYFO712	0,120	2,05
NYFO14	NYFO614	NYFO714	0,140	2,75
NYFO16	NYFO616	NYFO716	0,160	3,40
NYFO18	NYFO618	NYFO718	0,180	4,40
NYFO20	NYFO620	NYFO720	0,200	5,50
NYFO22	NYFO622		0,220	6,55
NYFO25	NYFO625		0,250	7,80
NYFO30	NYFO630		0,300	10,10
NYFO35	NYFO635		0,350	13,20
NYFO40	NYFO640		0,400	16,50



## FENDREEL

Questo nylon Giapponese è un prodotto eccezionale per la pesca con canna e mulinello. Grazie alla sua completa assenza di memoria meccanica, evita il formarsi di qualsiasi tipo di spira in fase d'imbobinamento.

*This Japanese nylon is an exceptional line for rod-and-reel fishing. Thanks to its absolute lack of line memory, it forms no coils of any type - thus eliminating line twists - as it comes off the spool for reel loading.*

CODE 150mt	CODE 300mt	Diameter (mm)	KG
NYFE10		0,105	1,40
NYFE12		0,128	2,00
NYFE14	NYFE614	0,148	2,60
NYFE16	NYFE616	0,168	3,55
NYFE18	NYFE618	0,185	4,50
NYFE20	NYFE620	0,205	5,50
NYFE22	NYFE622	0,225	6,95
NYFE25	NYFE625	0,250	8,40
NYFE30	NYFE630	0,300	12,10
NYFE35	NYFE635	0,350	15,90
NYFE40	NYFE640	0,400	20,15
NYFE45	NYFE645	0,450	27,50
NYFE50	NYFE650	0,500	35,15



## POWER

L'altissima tenacità al nodo e la straordinaria resistenza all'abrasione, rendono questo monofilo adatto ad ogni tipologia di pesca, sia in acque dolci che in mare.

*High knot strength and extraordinary resistance to abrasion make this monofilament suitable for every type of fishing, in both fresh waters and at sea.*

CODE 200mt	CODE 1000mt	Diameter (mm)	KG
NYPO12	NYPO912	0,120	1,80
NYPO14	NYPO914	0,140	2,30
NYPO16	NYPO916	0,160	3,10
NYPO18	NYPO918	0,180	4,05
NYPO20	NYPO920	0,200	5,25
NYPO22	NYPO922	0,220	6,30
NYPO25	NYPO925	0,250	7,50
NYPO30	NYPO930	0,300	9,80
NYPO35	NYPO935	0,350	12,70
NYPO40	NYPO940	0,400	15,90



## ARWEN

Questo eccezionale monofilo è stato studiato appositamente per la pesca all'inglese e tutte le pesche dove necessitano di un nylon affondante. Il basso allungamento, un'alta resistenza all'abrasione, un'abassa memoria meccanica, una bobinatura a spire parallele antitorzione, un particolare processo di stiratura, rendono l'ARWEN INGLESE, un nylon specifico davvero unico sul mercato.

CODE 150mt	Diameter (mm)	KG
NYING14	0,148	2,60
NYING16	0,168	3,30
NYING18	0,185	4,10
NYING20	0,205	4,90
NYING22	0,230	5,80

*This exceptional monofilament is specially designed for match fishing: low stretch factor, high abrasion resistance, low mechanical memory, anti-twist parallel winding, a special pre-stretching process. All these features make ARWEN INGLESE a specific nylon line without equal on the market.*

## METHOD

Questo monofilo, dotato di una straordinaria resistenza all'abrasione, allo stress, e di una elasticità controllata, è davvero indicato per la pesca a Feeder, in modo tale da permettere lanci più lunghi e precisi. Il migliore esistenti oggi sul mercato.

*This monofilament, featuring extraordinary resistance to abrasion and to stress and controlled stretch, is a perfect choice for feeder fishing since it permits longer and more accurate casts. A higher-quality nylon compared to many other similar lines available on today's market.*

CODE 250mt	Diameter (mm)	KG
NYME014	0,140	2,50
NYME016	0,160	3,20
NYME018	0,180	3,90
NYME020	0,200	4,70
NYME022	0,220	5,90
NYME025	0,250	7,20
NYME028	0,280	8,60
NYME030	0,300	10,15





**RBS**

Monofilo giapponese alta tenacità al nodo. Allungamento medio e resistentissimo all'abrasione. I pallini di piombo anche molto duri, non intaccano minimamente questo filo e possono essere spostati più volte lasciando la lenza inalterata.

*A memory-free Japanese monofilament, very high knot strength and incredible resistance to abrasion. On this monofilament, you can move the lead sinkers, even the hardest, any number of times without nicking the line in the least.*

CODE 100mt	CODE 600mt	Diameter (mm)	KG
NYRB08		0,080	0,95
NYRB09	NYRB609	0,090	1,05
NYRB10	NYRB610	0,105	1,30
NYRB12	NYRB612	0,125	1,90
NYRB14	NYRB614	0,145	2,50
NYRB16	NYRB616	0,165	3,40
NYRB18	NYRB618	0,186	4,40
NYRB20		0,206	5,50
NYRB22		0,228	6,80
NYRB25		0,250	8,20
NYRB31		0,300	11,90
NYRB35		0,350	15,40
NYRB40		0,400	19,70

**ATOMIC LINE**

Questo nylon è veramente dotato di un buonissimo rapporto qualità/prezzo. Monofilo Kristal ha un'ottima resistenza al nodo e all'abrasione. È indicato sia per la pesca in acque dolci che in mare.

*This line features a very good quality/price ratio. Monofilament with clear crystal color, excellent knot strength and abrasion resistance. It's recommended for fishing both inland and salt and salty waters since it is highly resistant to salinity.*

CODE 100mt	CODE 500mt	Diameter (mm)	KG
NYATO12		0,120	1,80
NYATO14		0,140	2,10
NYATO16	NYAT615	0,160	2,40
NYATO18	NYAT618	0,180	3,50
NYATO20	NYAT620	0,200	4,20
NYATO22	NYAT622	0,220	4,50
NYATO25	NYAT625	0,250	6,00
NYATO30	NYAT630	0,300	8,40
NYATO35	NYAT635	0,350	9,50
NYATO40	NYAT640	0,400	13,20
NYATO45	NYAT645	0,450	15,40
NYATO50	NYAT650	0,500	21,40



**OKY**

Questo monofilo di colore celeste risulta morbido e scorrevole. La sua resistenza al nodo e alla trazione è molto elevata. Ottimo sia in acque dolci che per la pesca in mare.

*This grey-blue color monofilament is very supple and easy-running. Its knot strength and traction resistance is also very high. A fine choice for both fresh and salt water uses.*

CODE 150mt	Diameter (mm)	KG
NYOK014	0,140	2,05
NYOK016	0,160	2,60
NYOK018	0,180	3,40
NYOK020	0,200	4,20
NYOK022	0,220	5,05
NYOK025	0,250	6,00
NYOK030	0,300	8,20
NYOK035	0,350	10,50
NYOK040	0,400	13,00
NYOK045	0,450	15,30
NYOK050	0,500	17,80





## XILO

Ogni bobina di Xilo viene testata metro per metro da micro sensori laser, che ne garantiscono con precisione assoluta il diametro espresso sulla confezione. Il carico di rottura contraddistingue questo nylon da tutti gli altri presenti sul mercato.

*Each spool of Xilo is tested, meter by meter, with laser micro-sensors to guarantee the absolute precision of the line diameter. The breaking strengths stand head and shoulders above any other currently-available nylon. Superior reliability for sure catches at any level.*

CODE 50mt	Diameter (mm)	KG
NYXI053	0,053	0,41
NYXI059	0,059	0,48
NYXI064	0,064	0,59
NYXI069	0,069	0,70
NYXI079	0,079	0,89
NYXI090	0,090	1,15
NYXI104	0,104	1,48
NYXI117	0,117	1,89
NYXI128	0,128	2,35
NYXI148	0,148	2,98
NYXI165	0,165	4,15
NYXI185	0,185	5,70
NYXI205	0,205	7,82
NYXI222	0,225	8,40
NYXI25	0,250	9,80

## MIMETIX

Il MIMETIX subisce il processo Fluorine, che lo rende un nylon da finali eccellente. Questo monofilo caratterizzato da una morbidezza straordinaria, è inoltre dotato di grande resistenza alla trazione, all'abrasione e al nodo.

*The MIMETIX receives Fluorine process treatment, which makes it an excellent leader nylon. This monofilament, characterized by extraordinary suppleness, also exhibits high resistance to traction and abrasion and knotting strength.*

CODE 50mt	Diameter (mm)	KG
NYMI064	0,064	0,53
NYMI071	0,071	0,65
NYMI083	0,083	0,81
NYMI090	0,090	0,96
NYMI103	0,103	1,29
NYMI110	0,110	1,57
NYMI123	0,123	2,03
NYMI138	0,138	2,48
NYMI148	0,148	2,82
NYMI158	0,158	3,65
NYMI170	0,170	4,57
NYMI190	0,190	5,63

# TERMINAL LINES



## STREAM

Diametri reali, carichi di rottura verificati tramite test, morbidezza estrema e leggerezza oltre la norma: tutte caratteristiche che collocano lo STREAM al vertice di categoria. Il "FLUORINE PROCESS" garantisce inalterabilità del prodotto.

*Real diameters and breaking strengths verified by testing, extreme suppleness, and out-of-the-ordinary light weight: all characteristics that place STREAM at the top of its category.. The special "FLUORINE PROCESS" treatment guarantees that the product will remain unaltered even after a great number of catches and that bait will be presented naturally.*

CODE 50mt	Diameter (mm)	KG
NYSTR064	0,064	0,62
NYSTR070	0,070	0,77
NYSTR080	0,080	0,94
NYSTR090	0,090	1,10
NYSTR103	0,103	1,49
NYSTR115	0,115	1,90
NYSTR125	0,125	2,39
NYSTR145	0,145	2,95
NYSTR165	0,165	4,05
NYSTR185	0,185	5,40
NYSTR200	0,200	6,80



**ONDA MILLE**

Veramente il "NUMERO UNO" per il long casting applicato a tutte le tecniche di pesca, sia d'acqua dolce che d'acqua salata. Il nylon preferito dai nostri agonisti nazionali di surf casting.

A true "NUMBER ONE" for long casting in all specialties, both freshwater and saltwater. This is the nylon line preferred by our national surfcasting competitors.

CODE 300mt	CODE 2000mt	Diameter (mm)	KG
NYOM14	NYOM514	0,140	2,70
NYOM16	NYOM516	0,160	3,30
NYOM18	NYOM518	0,180	3,80
NYOM20	NYOM520	0,200	4,80
NYOM22		0,220	5,90
NYOM25	NYOM525	0,250	7,10
NYOM30	NYOM530	0,300	9,10
NYOM35	NYOM535	0,350	11,90

**SURF HOLO**

Bobinatura a spire parallele antitorione, tripla siliconatura di protezione per la salsedine, alta resistenza all'abrasione, formidabile serrata al nodo bagnato e un colore giallo fluorescente rendono questo nylon un leader nel suo genere. E' adatto ad ogni tipo di pesca, sia d'acqua dolce che d'acqua salata, ma particolarmente indicato per il SURF CASTING.

CODE 300mt	Diameter (mm)	KG
NYHO14	0,140	2,90
NYHO16	0,160	3,50
NYHO18	0,180	4,20
NYHO20	0,200	4,90
NYHO22	0,220	6,20
NYHO25	0,250	7,30
NYHO30	0,300	9,20

Antitorion parallel spooling, triple silicon treatment which protects from the salt. Extraordinary resistance to abrasion and to the wet knot, its yellow fluorescent finishing makes this nylon a leader in the market. It's suitable for any fishing technique, both in fresh and salt water. Particularly indicated for SURF CASTING.



**TAPERED**

Il LURS TAPERED è stato sottoposto ad uno speciale trattamento ai siliconi, il quale oltre che a favorire la fuoriuscita delle spire in fase di lancio, lo protegge dall'azione corrosiva della salsedine. Il suo diametro si mantiene costante per 200 mt, per poi variare negli ultimi 20 mt finali. Questo lo rende molto simile ad uno shock leader, con la differenza che non sussiste alcun nodo di giunzione tra i due differenti diametri. Validissimo per tutte le tecniche di long cast, sia d'acqua dolce che d'acqua salata.

CODE 220mt	Diameter (mm)
NYLUTA1437	0,140 > 0,370
NYLUTA1637	0,160 > 0,370
NYLUTA1837	0,180 > 0,370
NYLUTA2047	0,200 > 0,470
NYLUTA2057	0,200 > 0,570
NYLUTA2357	0,235 > 0,570
NYLUTA2657	0,260 > 0,570

The LURS TAPERED line is given a special silicon treatment that not only ensures that the line coils come smoothly off the reel during casting but also protects the line from the corrosive action of salt. The diameter is constant for 200 meters and varies in the last 20 meters. This makes the line very similar to a shock leader fitted rig, with the difference that there is no junction between the two different diameters. Great for all long casting techniques, in both fresh and salt water.



**SHOCK LEADER**

Questo nylon conico, è stato ideato appositamente per la congiunzione tra una lenza madre sottile ed uno spezzone di diametro maggiore, utile a reggere lo strappo del lancio. Il colore CLEAR, evita che quei riflessi prodotti in acqua da equivalenti shock colorati, possano essere motivo dei noti attacchi da parte del pesce serra.

CODE 15mt	Diameter (mm)
NYLUSH1647	0,160 > 0,470
NYLUSH1657	0,160 > 0,570
NYLUSH1847	0,180 > 0,470
NYLUSH1857	0,180 > 0,570
NYLUSH2057	0,200 > 0,570
NYLUSH2357	0,230 > 0,570

This conically-tapered nylon is designed especially for the combination of a thin-section main line and a length of greater diameter, appropriate for resisting the shock factor of the cast. The CLEAR color obviates the reflections produced in the water by equivalent colored shocks, which can be the cause of the attacks on lines by tailor fish.

## AXIAL

Prodotto in Giappone e realizzato per la pesca con canne a mulinello. Le sue caratteristiche sono un'ottima tenuta al nodo, una stupenda morbidezza, un basso allungamento, una totale assenza di memoria meccanica. Grazie alle particolari resine applicate sul nylon, questi risulta inalterabile dagli agenti atmosferici e resistentissimo all'abrasione. Ideale per la pesca a surf casting, bolentino e ledgering, oltre che per il light drifting a Palamite e Lampughe.

CODE 300mt	Diameter (mm)	KG
NYAX18	0,180	3,72
NYAX20	0,200	4,91
NYAX22	0,225	6,04
NYAX25	0,255	7,40
NYAX29	0,290	9,24
NYAX34	0,340	12,72

*Produced in Japan, this nylon is specially designed for reel fishing. Extremely soft, it offers excellent knot strength, low stretch and zero memory. In addition to this, the monofil has been treated with a silicone-type resin for ultimate weather and abrasion resistance. All these features make the AXIAL ideal for surf casting, bottom fishing, ledgering, and bonito light drifting.*



## BIG-GAME

Questo nylon di ultima generazione, è dotato di un'ottima tenacità al nodo, resistenza all'abrasione e bassa memoria meccanica; l'ideale per il big game e quindi per la cattura di grandi esemplari. Un ulteriore trattamento silconico, conferisce al LURS BIG GAME grande resistenza alla salsedine.

*A latest generation Japanese monofilament which offers excellent knot breaking strength, abrasion resistance and low mechanical memory; excellent for big game and for big catches. Its exclusive silicon treatment offers better protection against salinity.*

CODE 600mt	Diameter (mm)	Lbs
NYLUBG20	0,40	20
NYLUBG30	0,50	30

CODE 800mt	Diameter (mm)	Lbs
NYLUBG50	0,70	50
NYLUBG80	0,90	80



## RED & YELLOW DRAGON

Questi due nylon nei colori rosso e giallo fluorescenti li rendono ben visibili in ogni situazione di luce, mentre al contrario, si affievoliscono fino quasi all'invisibilità, una volta immersi in acqua. Grazie al particolare processo di siliconatura, consente una veloce realizzazione di nodi praticamente perfetti, anche nei suoi diametri più grandi. Un'altra caratteristica unica di questo rivoluzionario nylon, è quella di rimanere incredibilmente lineare e morbido, anche dopo lunghi periodi di utilizzo.

*The red and yellow fluorescent colors make these two nylons clearly visible in all light conditions while at the same time they become almost invisible, once in the water. A special silicon-coating process, permits a rapid creation of perfect knots, even in the largest diameters. This revolutionary nylon remains linear and incredibly soft, even after long period of use.*

CODE 600mt	Diameter (mm)	Lbs
NYD12	0,300	12
NYD20	0,400	20
NYD30	0,470	30

CODE 800mt	Diameter (mm)	Lbs
NYD50	0,650	50
NYD80	0,880	80

CODE 600mt	Diameter (mm)	Lbs
NYRE12	0,300	12
NYRE20	0,400	20
NYRE30	0,470	30

CODE 800mt	Diameter (mm)	Lbs
NYRE51	0,650	50
NYRE81	0,880	80





**SOLD OUT**



**BLACK TIGER 3500**

Mulinello di ottima qualità e fattura, con frizione anteriore a regolazione micrometrica. Proposto in una sola misura, il Black Tiger è stato studiato appositamente per l'agonismo, ed in particolare per le tecniche inglese e bolognese. Ampia bobina match e pomello ergonomico in gomma dura.

*Excellent quality and manufacturing reel, featuring a micro metric front drag. One size only, the Black Tiger is developed for competition fishing, expressly for bolognese and waggler fishing. Ample match spool and hard rubber ergonomic handle knob.*



0,30/200 - 0,40/150

**EXTRA GRAPHITE SPOOL**

SIZE

**SOLD OUT**



0,8/200 - 0,22/150



MATCH





## SLEEK

Il mulinello SLEEK, si fa notare oltre che per il look accattivante per la sua leggerezza. La particolarità di questo mulinello, è il suo corpo di piccole dimensioni abbinato ad una larga bobina, ideale per il Feeder, per la pesca all'inglese, e per la pesca in passata con la bolognese. Un'altra caratteristica molto importante è la sua frizione micrometrica la quale ci permette di pescare con terminali sottilissimi senza correre il rischio, una volta tarata, di rompere il nylon sulle ferrate.

*The Sleek features a very light weight and a nice look. The main feature of this reel is the small dimension of the body and the large arbor spool, excellent for feeder, waggler, bolognese fishing. Another main feature is the micrometric drag that will allow to fish very thin hook lengths avoiding line breakage on the strike.*

SIZE	CODE			
3500	MULSLO1A	5.1:1	0,20/200 - 0,25/150	MATCH



## TINDAL

Fluidità e versatilità sono i cavalli di battaglia del TINDAL. Si tratta di un mulinello a frizione anteriore adatto per tutti i tipi di pesca in cui l'affidabilità sia il requisito imprescindibile. Le quattro misure disponibili permettono di rispondere alle esigenze di spinning, feeder, bolognese, ledgering e molte altre tecniche sia in acqua dolce che salata.

*The main figures of TINDAL are its great fluidity and versatility. Tindal is a front drag reel for any kind of fishing where reliability is the main issue. The range of 4 different available sizes meet the needs of different fishing style, like feeder, bolo, ledgering and many others, both for fresh and salt water.*

SIZE		
2500	0,16/250 - 0,20/150	Match
3500	0,18/250 - 0,25/150	Match





**SOLD OUT**

**EXTRA GRAPHITE SPOOL**



SIZE	mm/mt
4000	0,25/250 - 0,30/200 - 0,35/150
6000	0,35/300 - 0,40/200 - 0,45/130



**SIMBA**

Le rifiniture curate e il corpo bianco perla, sono solo caratteristiche estetiche, ma Colmic come in ogni suo prodotto non ha voluto lasciare niente al caso, neanche i dettagli ininfluenti. Simba, dotato di 9 cuscinetti, bobina in alluminio, frizione micrometrica, ingranaggi di qualità ed EVA knob, è un concentrato di qualità e affidabilità studiato per supportare al meglio il vostro divertimento.

*Outfit matters, that's why the Colmic staff took great care in developing the finishing and the pearled-white body of Simba. This high quality reel is equipped with 9 ball bearings, aluminum spool, micrometric drag, quality gears and EVA knob. Offering at the same time great performances and reliability this reel will offer the maximum support in enjoying the fishing experience.*

SIZE	mm/mt	Match
4000	0,210 - 0,20/160 - 0,22/120	Match
6000	0,25/340 - 0,40/250 - 0,45/180	Regular

**SOLD OUT**



**SOLD OUT**

**DAKUN**

Il mulinello all round a frizione anteriore destinato a chi vuole un oggetto semplice da usare per divertirsi all'aria aperta e godersi la gioia della pesca.

*Dakun is an all round front drag reel, especially conceived for the anglers requiring a simple and yet functional product to fully enjoy the leisure of fishing.*

SIZE	mm/mt
6000	0,35/270 - 0,40/210 - 0,50/130

**SOLD OUT**



# REAR DRAG



**SOLD OUT**

**SOLD OUT**

**EXTRA GRAPHITE SPOOL**



SIZE	mm/mt
4000	0,30/275 0,35/200 0,40/150
5000	0,30/300 0,35/225 0,40/175

## ELIX

Il mulinello a frizione posteriore pensato per tutte le pesche in cui affidabilità e controllo sono le qualità in grado di fare la differenza. La REAR DRAG micrometrica è il miglior biglietto da visita per l'ELIX.

*This rear clutch reel is designed for all types of fishing in which reliability and control are the qualities that can make a difference. The micrometrical, are the best features of the ELIX.*

SIZE	mm/mt	Match
4000	0,30/275 - 0,20/175 - 0,25/150	Match
5000	0,30/300 - 0,35/225 - 0,40/175	Regular

**SOLD OUT**

## TWISTER

Il mulinello REAR DRAG, con ottimo rapporto qualità prezzo, da impiegare pescando a bolognese, tremarella, inglese.

*The Real Drag reel offers a great quality/price ratio, recommended for bolo and match fishing.*

SIZE	mm/mt
3000	0,30/240 - 0,25/200 - 0,30/140

**SOLD OUT**





## W-BEACH 6500

Mulinello a bobina fissa e frizione anteriore, destinato al beach ledgering ed alle specialità di pesca a fondo in acqua dolce. L'ampia bobina match di cui è dotato, consente di bobinare nylon sottili con estrema precisione. Trattamento anti corrosione, pomello ergonomico in gomma dura e due bobine aggiuntive in dotazione.

*Front drag fixed spool reel, expressly developed for the beach ledgering technique and the bottom fishing generic fishing in fresh water. The capable match spool equipping the reel allow a perfect spooling of very thin lines. Saltwater resistant, ergonomic handle hard rubber knob and two spare spools.*

ITEM	mm/mt	Match Regular
1	0,18/300 - 0,22/250	match
2	0,25/300 - 0,30/200	regular

**EXTRA ALUMINIUM SPOOLS**

SIZE	mm/mt
6500	0,18/300 - 0,22/250

**SOLD OUT**







## CANBERRA

Il CANBERRA con dieci cuscinetti a sfera sigillati ed inossidabili, per prevenire totalmente la corrosione derivante dall'azione della salsedine. L'ampiezza della bobina lo rende ideale per tutte le tecniche di pesca a fondo, sia in mare che in acque interne, ed anche per molte delle tecniche praticabili da natante.

*The CANBERRA also boasts a system featuring ten sealed rustproof bearings, offering total prevention of the corrosion deriving from the action of salt. The size of the spool and its great capacity make it ideal for all deep-water fishing, both at sea and in inland waters, as well as for many of the techniques that can be performed from a boat.*

ITEM



01 0,30/350 - 0,40/250 - 0,50/150

**EXTRA GRAPHITE SPOOL**

SIZE

**SOLD OUT**



5500 0,30/300 - 0,25/250 - 0,30/190

## BLACK HAWK

Questo bellissimo mulinello, compatto leggero nato per il Surf Casting, si avvale di dieci cuscinetti a sfera sigillati ed inossidabili, utili a prevenire totalmente la corrosione derivante dall'azione della salsedine.

*This very fine reel exploits a system featuring ten sealed rustproof bearings, offering total prevention of the corrosion deriving from the action of salt.*

SIZE



6500 0,35/400 0,45/250  
7500 0,35/430 0,45/300

**EXTRA ALUMINIUM SPOOLS**

SIZE

CODE



6500 **SOLD OUT** 4,8:1 0,22/350 0,26/280  
7500 MULBL02 4,3:1 0,22/500 0,26/350





**SOLD OUT**



**SOLD OUT**

**10+1 BALL BEARINGS**

**1**

**2**

**8+1 BALL BEARINGS**

**W-SURF 8000**

Mulinello a bobina fissa e frizione anteriore, destinato al surf casting ed alle tecniche di pesca a fondo in acqua dolce. Ampia bobina match, pomello ergonomico in gomma dura e trattamento anti corrosione del corpo con schermatura dei cuscinetti. Ideale per l'agonismo, viene corredato di due extra bobine in dotazione.

Front drag fixed spool reel, developed for surf casting and fresh water bottom fishing. Ample match spool, ergonomic hard rubber handle knob, saltwater resistant body and waterproof ball bearings. Perfect for competition fishing, equipped with two extra spare spools.

**GRIFF**

Il GRIFF un mulinello dalla potenza straordinaria, studiato e concepito per essere utilizzato nelle più svariate discipline, dal mare alle acque interne. Indicato per tutte le tecniche di pesca ed in particolare per il Jigging.

The GRIFF is definitely a very fine reel, conceived and designed to be used in various disciplines from sea to inland waters. Designed for enhanced casting, special protective paint, multi disc drag and many other interesting details. Perfect for all deep fishing techniques, both from land and from boat, in any environment.

ITEM	mm/mt	Match Regular
1	0,20/400 - 0,25/300	match
2	0,35/300 - 0,40/200	regular

**EXTRA ALUMINIUM SPOOL**

SIZE	mm/mt
8000	0,20/400 - 0,25/300

**SOLD OUT**

size	mm/mt
7000	0,30/430 - 0,35/320 - 0,45/200
8000	0,30/500 - 0,35/370 - 0,45/225

**EXTRA GRAPHITE SPOOL**

SIZE	CODE	mm/mt
7000	<b>SOLD OUT</b>	0,25/330 - 0,30/250
8000	<b>SOLD OUT</b>	0,25/220 - 0,30/150



# PROFESSIONAL REELS

STAINLESS STEEL



## KRAG EVO

IL KRAG EVO è ideale per tutte le pesche in cui la potenza e l'affidabilità sono requisiti imprescindibili. Dotato di Brass pinion gear, albero e ingranaggi in acciaio sovradimensionati, cuscinetti stagni, corpo in alluminio, che lo rende ideale per provare l'emozione della pesca al tonno e a tutti i grandi pelagici. L'impugnatura da combattimento in alluminio rifinita con gli stessi colori accattivanti della bobina è il valore aggiunto ad una meccanica pensata per la pesca estrema. Il KRAG EVO 7000 con un MAX DRAG 25KG è estremamente potente rispetto a quelle dei mulinelli di questa misura.

*The KRAG EVO is conceived for all types of fishing in which the power and reliability are essential. It's equipped with Brass pinion gear, shaft and steel gears, oversized sealed bearings, aluminum body and salt resistance are the main features of Krag which is the perfect ally to experience the thrill of tuna. The new aluminum handle, refined with the same attractive colors of the spool, makes this new reels a real evolution in extreme fishing. The KRAG EVO 7000 is provided with a MAX DRAG 25KG is extremely powerful than those reels of the same size.*

MODEL	CODE	GEAR RATIO	MAX DRAG	NYLON (mm/mt)	BRAIDED VASTAR (Lbs/mt)
KRAG 7000	MULKR70	4.9:1	25 Kg	0,30/350 - 0,40/200	40/400 - 60/175



## MAX DRAG 15 KG

## TYPHON

I tonni sono tornati nel nostro mare in grande quantità! Le catture di dentici, ricciole e grossi pesci pelagici sembrano sempre più all'ordine del giorno! Colmic con il TYPHON 6000 è in grado di fornire i mulinelli adeguati alle necessità ormai avvertite da tutti gli amanti delle emozioni forti. TYPHON è stato ideato per il affrontare pesci che solitamente sono prerogativa solo del Big Game. Il corpo e il rotore interamente in alluminio, il Brass Pinion Gear e i cuscinetti Stainless Steel schermati, sono le certezze offerte da questo prodotto adatto a resistere a sollecitazioni e stress importanti. La frizione con max drag 15kg permetterà di insidiare i tonni senza problemi. Gli ingranaggi resistenti e duraturi, immersi in un corpo interamente in alluminio, sono il cuore di un mulinello accattivante, sia per l'estetica, sia per le performance che vi regalerà.

*The TYPHON is suitable for all the fishing needs now perceived by all those whose love the strong emotions. The TYPHON has been conceived to deal with the Big Game fishes only. The aluminum body and the rotors, the Brass Pinion Gear and Stainless Steel Ball Bearing are the certainties offered by this product suitable to withstand important stresses. The clutch has a max drag 15 kg allowing to mine the tunnies without any trouble. The resistant and durable gears featured by an aluminum body, they are the heart of an attractive reel, both for aesthetics and for its performance.*

STAINLESS STEEL



MODEL	NYLON (mm/mt)	BRAIDED VASTAR (Lbs/mt)
TYPHON 6000	0,35/400 - 0,45/250	60/375 - 80/250

**SOLD OUT**



**SOLD OUT**

**VS 12**

**VS 10**

**VS 10LH**

## VS - SERIES

Combattere dentici, ricciole, cernie, tonni di media taglia, tesori inestimabili dei nostri mari, con degli attrezzi così leggeri e divertenti sembrava veramente un sogno irrealizzabile fino a poco tempo fa, ma l'avvento dei nuovi trecciati tipo Vastar con i loro ridottissimi diametri uniti alla straordinaria resistenza hanno fatto sì da spingere questa storica azienda a produrre questi mulinelli dalle caratteristiche uniche. Risultato di un know how produttivo acquisito in tanti anni, la serie OMOTO VS con i suoi tre modelli VS12, VS10, VS10LH, e' un concentrato di dimensioni, potenza, velocità e leggerezza il tutto accompagnato da un disegno moderno di grande stile.

*Up to a short time ago battling against sea bream, amberjack, groupers and medium-size tuna, the priceless treasures of our seas, with equipment so light and such fun would have seemed like an impossible dream, but the advent of the new braids, such as Vastar, with their highly reduced dimensions combined with extraordinary strength, has enabled this historic company to produce these reels with genuinely exceptional features. The result of a manufacturing know-how acquired over many years, the OMOTO VS series with its three models - VS12, VS10 and VS10LH - is a concentrate of dimensions, power, speed and lightness, all accompanied by an extremely stylish modern design.*

MODEL	CODE		LBS	RED DRAGON	BRAIDED VASTAR	WEIGHT
VS12RH	MULOM29B	5.9:1	25	30lbs - 290mt	40lbs - 400mt	580gr
VS10RH	MULOM29	5.2:1	18	20lbs - 280mt	40lbs - 360mt	480gr
VS10LH	MULOM28A	5.2:1	18	20lbs - 280mt	40lbs - 360mt	480gr

# TROLLING



**OMOTO**<sup>®</sup> MIT  
The Advantage Over The Competition



30LBS



25LBS



20LBS



15LBS



10LBS

## GTR - SERIES

Molto spesso citiamo il rapporto tra qualità e prezzo, ma mai come in questo caso la citazione si rivela più azzeccata. Questa serie di mulinelli costruita su monoblocchi in ABS e grafite, dalle indiscusse e ormai comprovate caratteristiche di resistenza ed estrema leggerezza, eredita dai mulinelli superiori la componentistica interna e la precisione degli assemblaggi. Ovviamente la produzione delle scocche, che si svolge con procedimenti di fusione e non di lavorazione a freddo sul tornio, risulta meno dispendiosa in un'economia di scala ed è sicuramente meno "pregiata", ma non per questo è meno affidabile e duratura. I vantaggi nella scelta di questi mulinelli non sono soltanto economici ma dovuti anche all'estrema leggerezza dei materiali utilizzati, i quali consentono un ulteriore alleggerimento delle proprie attrezzature, lasciando spazio al solo gusto di pescare.

*Value for money is something we talk a lot about, but never with quite as much relevance as in this case. This series of reels built of single pieces of ABS and graphite, boasting undisputed features of strength and extreme lightness, inherits from the superior models the internal components and the care taken in the assembly of all the mechanical parts. Naturally, the production of the frames, which is carried out using casting techniques rather than cold-forging on the lathe, is less expensive in the sense of a scale economy and is obviously less "precious", but this does not mean that it is any less reliable or long-lasting. The advantages of choosing these reels are not just economic, but also due to the extreme lightness of the materials used, which permit a further lightening of the equipment as a whole, so that you are left with simply the pleasure of fishing.*

MODEL	CODE		LBS	BRAIDED VASTAR	RED DRAGON	WEIGHT
GTR T20	<b>SOLD OUT</b>	3.8:1	20	60lbs/500mt	30lbs/380 mt- 25lbs/430mt	770gr
GTR T25	MULOM13	3.8:1	25	60lbs/600mt	30lbs/470 mt- 40lbs/380mt	790gr
GTR T30	MULOM14	3.8:1	30	80lbs/700mt	30lbs/650mt - 50lbs/480mt	1130gr

# ONE 2.0

## EVOLUTION



**INCLUDED**



# ONE 2.0

## ONE 2.0 EVOLUTION

- ▮ 1 Siège anatomique 2.0.
  - ▮ 1 Module HI-Tech: 2 tiroirs frontaux + porte lignes. 42x32cm H.5cm (tiroirs: 29,5x18cm H.3.5).
  - ▮ 1 Module HI-Tech Porte lignes 42x32cm H.3,5cm.
  - ▮ 1 Casier avec Module HI-Tech 2 tiroirs frontaux + porte lignes. 42x32cm H.5cm (tiroirs: 29,5x18cm H.3.5).
  - ▮ 4 Jambes télescopiques H.50cm Ø30mm.
  - ▮ 2 Jambes base pliant télescopiques H. 60cm Ø30mm.
  - ▮ 1 Plateau latéral tecno Form 300 (37cm x 50cm).
  - ▮ 1 Support porte bourriche
  - ▮ 2 Supportes pour cannes latérales
  - ▮ 1 Porte parapluie "Long".
  - ▮ 1 Bandoulière rembourrée ergonomique
  - ▮ 1 Barre frontal inclinable.
  - ▮ 14 porte lignes
- ▮ *Asiento anatómico 2.0.*
  - ▮ 1Modulo HI-Tech: 2 cajones frontales + porta sedales. 42x32cm H.5cm (tiroirs: 29,5x18cm H.3.5).
  - ▮ 1Modulo HI-Tech Porte lignes 42x32cm H.3,5cm.
  - ▮ Maletín con Modulo HI-Tech:2 cajones frontales + porta sedales. 42x32cm H.5cm (tiroirs: 29,5x18cm H.3.5)..
  - ▮ 4 *Patas telescópicas* H.50cm Ø30mm.
  - ▮ 2 *Patas telescópicas para reposa pie* H. 60cm Ø30mm.
  - ▮ 1 *Bandeja lateral Tecno Form 300* (37cm x 50cm).
  - ▮ 1 *Apoya nasa*
  - ▮ 2 *Apoyas cañas laterales*
  - ▮ 1 Porte parapluie "Long".
  - ▮ 1 Bandoulière rembourrée ergonomique
  - ▮ 1 Barre frontal inclinable.
  - ▮ 14 porta sedales

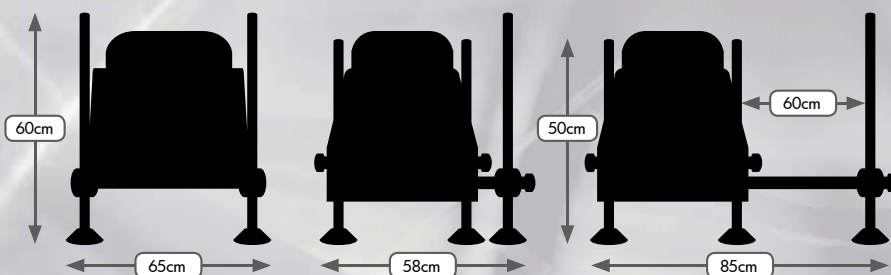

### WHITE/BLACK

CODE: PA0800



### BLACK/WHITE

CODE: PA0801



# KROSS



**INCLUDED**





## KROSS

CODE: PA0730

- ▲ 1 Seduta Anatomica 2.0.
  - ▲ 1 Modulo HI-Tech 2 cassettei forntali con ribalta portalenze. 42x32cm H.5cm (cassetti: 29,5x18cm H.3.5).
  - ▲ 1 Modulo HI-Tech Porta-Lenze 42x32cm H.3,5cm.
  - ▲ 1 Valigetta con Modulo HI-Tech Porta-Lenze (42x32cm H.3,5cm).
  - ▲ 4 Gambe Telescopiche H.50cm Ø30mm.
  - ▲ 1 Piatto Laterale Techno Form 300 (37cm x 50cm).
  - ▲ 1 Paletto Porta-Nassa.
  - ▲ 2 Appoggia-Canne Laterali.
  - ▲ 1 Porta Ombrello "Short".
  - ▲ 1 Tracolla Imbottita Ergonomica.
  - ▲ 1 Barra Frontale inclinabile
  - ▲ 28 Stecche portalenze
- ▲ 1 Anatomic seat 2.0.
  - ▲ 1 HI-Tech module: 2 frontal drawers + line winder tray 42x32cm H.5cm (drawers: 29,5x18cm H.3.5).
  - ▲ 1 HI-Tech Module: Line winder tray 42x32cm H.3,5cm.
  - ▲ 1 Sliding Case with HI-Tech Module: Line winder tray (42x32cm H.3,5cm).
  - ▲ 4 Telescopic legs H.50cm Ø30mm.
  - ▲ 1 Side tray Techno Form 300 (37cm x 50cm).
  - ▲ 1 Keep net holder .
  - ▲ 2 Lateral rod holders
  - ▲ 1 Umbrella holder "Short".
  - ▲ 1 Ergonomic padded shoulder strap
  - ▲ 1 Inclinable frontal Bar F
  - ▲ 28 Line winders

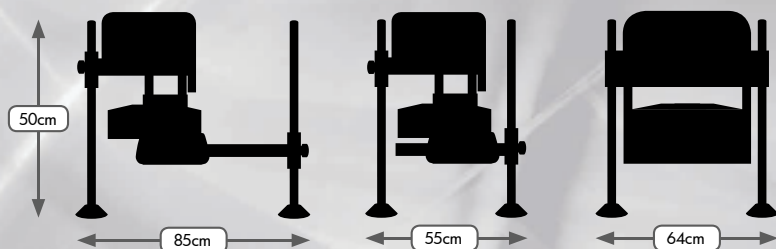

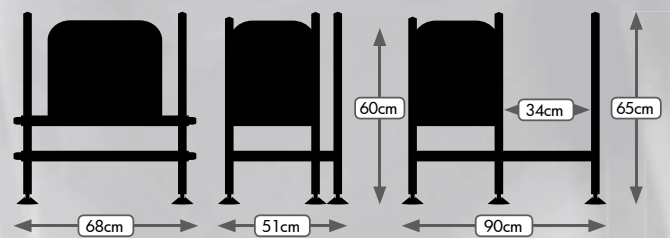

## HURRICANE

CODE: PA1004

- ▾ Seduta Anatomica con rivestimento in pelle Simil-Carbonio
- ▾ 1 Cassetto Laterale 25x39cm H.3,50cm
- ▾ 2 Cassetti Frontali 17x27cm H.3,50cm
- ▾ 1 Moduli Porta-Lenze H.3,5cm
- ▾ 2 Gambe Posteriori Telescopiche H. 60cm Ø30mm
- ▾ 2 Gambe Anteriori Telescopiche H. 65cm Ø30mm
- ▾ 2 Gambe Pedana Telescopiche H. 65cm Ø30mm
- ▾ Piatto Laterale 41x32cm
- ▾ Paletto Porta-Nassa su Pedana
- ▾ Tracolla Imbottita Ergonomica
- ▾ Livella Frontale + Livella Laterale

- ▾ *Anatomic seat with carbon look leather cover*
- ▾ *1 Lateral drawer 25x39cm H.3.5cm*
- ▾ *2 Front drawers 17x27cm H.3.5cm*
- ▾ *1 Rig Holder compartments H.3.5cm*
- ▾ *2 Telescopic back legs H.60cm Ø30mm*
- ▾ *2 Telescopic front legs H.65cm Ø30mm*
- ▾ *2 Footplate telescopic legs H.65cm Ø30mm*
- ▾ *1 Side tray 41x32cm*
- ▾ *1 Keep net holder on the footplate*
- ▾ *Ergonomic padded shoulder strap*
- ▾ *1 Front and 1 Lateral level*



# LEGEND SERIES



## LEGEND LIGHT 7000

CODE: PA1000C

- ▶ Seduta con rivestimento in pelle Simil-Carbonio
- ▶ 1 Modulo Porta-Lenze H.3,5cm
- ▶ 2 Cassetti Frontali 17x27cm H.3,50cm
- ▶ 1 Vano Portaoggetti H.16cm
- ▶ 4 Gambe Fisse H. 50cm Ø25mm
- ▶ Tracolla Imbottita Ergonomica
- ▶ Livella Frontale

- ▶ 1 Seat with carbon look leather cover
- ▶ 1 Upper rig holder compartment 3,5cm
- ▶ 2 Front drawers 27cmx17cm h.35mm
- ▶ 1 Accessory's storage h.16cm
- ▶ 4 Legs h.50cm Ø25mm
- ▶ 1 Shoulder strap for easy transport
- ▶ 1 Frontal level

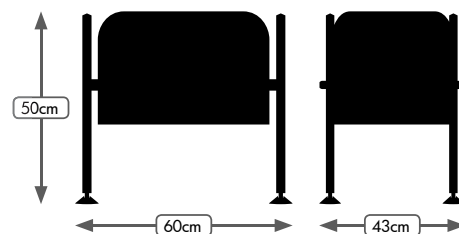

## LEGEND LIGHT 5000

CODE: PA1000B

- ▶ Seduta con rivestimento in pelle Simil-Carbonio
- ▶ 1 Modulo Porta-Lenze H.3,5cm
- ▶ 1 Vano Portaoggetti H.16cm
- ▶ 4 Gambe Fisse H. 50cm Ø25mm
- ▶ Tracolla Imbottita Ergonomica
- ▶ Livella Frontale

- ▶ 1 Seat with carbon look leather cover
- ▶ 1 Upper rig holder compartment 3,5cm
- ▶ 1 Accessory's storage h.16cm
- ▶ 4 Legs h.50cm Ø25mm
- ▶ 1 Shoulder strap for easy transport
- ▶ 1 Frontal level

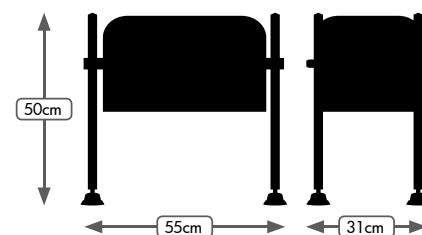



**LEGEND LIGHT 3000**

**CODE: PA1000A**

- ▀ Seduta con rivestimento in pelle Simil-Carbonio
  - ▀ 1 Vano Portaoggetti H.16cm
  - ▀ 4 Gambe Fisse H. 50cm Ø25mm
  - ▀ Tracolla Imbottita Ergonomica
  - ▀ Livella Frontale
- ▀ 1 Seat with carbon look leather cover
  - ▀ 1 Accessory's storage h. 16cm
  - ▀ 4 Legs h.50cm Ø25mm
  - ▀ 1 Shoulder strap for easy transport
  - ▀ 1 Frontal level

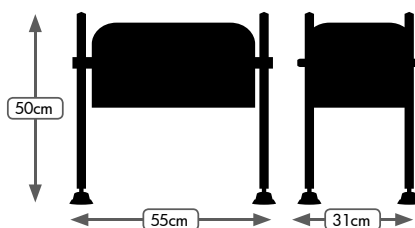

**LEGEND LIGHT 3000FST**

**CODE: PA1000D**

- ▀ Seduta con rivestimento in pelle simil-carbonio
  - ▀ 1 vano portaoggetti H.16cm
  - ▀ 4 gambe fisse H. 50cm Ø25mm
  - ▀ Tracolla imbottita ergonomica
  - ▀ Livella frontale
  - ▀ Piatto laterale pieghevole + gamba telescopica
- ▀ 1 Seat with carbon look leather cover
  - ▀ 1 Accessory's storage h. 16cm
  - ▀ 4 Legs h.50cm Ø25mm
  - ▀ 1 Shoulder strap for easy transport
  - ▀ 1 Frontal level
  - ▀ Folding side tray + telescopic leg

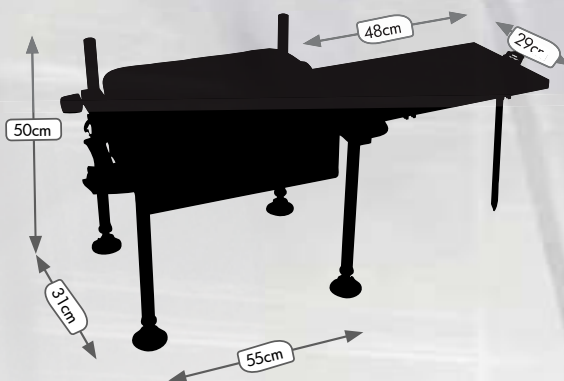

## FOLDING PRO

CODE: PA0900A76

Uno dei dati tecnici più rivoluzionari, oltre al peso che risulta essere veramente esiguo, è visibile nella zona centrale del manufatto dove si è deciso di lasciare uno spazio completamente vuoto. Grazie a questa caratteristica, il pescatore non dovrà più posizionarsi ai lati della pedana per adattarla alla sponda, come tradizionalmente avviene, ma potrà intervenire direttamente dall'interno, ottimizzando quindi tutta la fase di montaggio e privilegiando la stabilità ultima dell'oggetto. Dotata, infine, di predisposizione per l'aggancio opzionale di uno speciale kit traino.

*However, in addition to the weight that turns out to be really small, one of the most revolutionary technical data is visible in the central area where we have decided to leave a space completely empty. Thanks to this characteristic, the angler, will no longer use the traditional way to stand on the sides of the platform while adapting it to the bank, enabling him to perform this action directly from the inside space, thus optimizing the entire assembly operation and favouring the unit stability. Equipped, with a disposition that enables an optional coupling of a special towing kit.*



## PEDANA LEGEND

LEGEND PLATFORM

CODE: PA2010

Tutti i panchetti Legend Light (3000/5000/7000) sono proposti con gambe fisse mentre la Pedana Legend è dotata di due gambe telescopiche frontali. Qualora si rendesse necessario l'uso di gambe frontali telescopiche anche sul paniere per pescare su rive molto scoscese o argini irregolari è possibile acquistarle separatamente. Tale possibilità permette di avere sempre lo spazio necessario per l'applicazione di tutti gli accessori necessari durante l'azione di pesca come porta canne e vassoi.

*All the seat boxes of the Legend Light series (3000/5000/7000) come with fixed legs, while the Legend Platform instead is equipped with 2 frontal telescopic legs. In case you need frontal telescopic legs for the Seat Box also, so to improve the stability on steep shores, you can purchase them separately. The telescopic legs will allow you to adjust the seat boxes to practically all the most difficult ground, this way you will always use all the accessories (rod rests and side trays) at the best of their potential.*



**PIATTO TECNOFORM  
(37x50cm)**

TECHNOFORM SIDE TRAY 37x50cm  
CODE: PA02017

**SOLD OUT**



**SOLD OUT**

**PIATTO ABS  
(41x32cm)**

ABS SIDE TRAY 41x32cm  
CODE: PA2017



**PIATTO ALLUMINIO  
(50x40cm)**

ALUMINUM SIDE TRAY 50x40cm  
CODE: PA0900A43L



**PIATTO ABS  
(60x45cm)**

ABS SIDE TRAY 60x45cm  
CODE: PA0900A43H



Piatto con 2 gambe telescopiche  
Tray with 2 telescopic legs



**PIATTO ALLUMINIO  
(65x50cm)**

ALUMINUM SIDE TRAY 65x50cm  
CODE: PA0900A43I

Piatto con 2 gambe telescopiche  
Tray with 2 telescopic legs



# SIDE TRAY

## PIATTO ALLUMINIO (52x40cm)

ALUMINIUM SIDE TRAY 52x40cm

CODE: PA0900A43L1

Piatto con tenda  
Tray with tent



## PIATTO ALLUMINIO (65x50cm)

ALUMINIUM SIDE TRAY 65x50cm

CODE: PA0900A43I1

Piatto con 2 gambe telescopiche + tenda  
Tray with 2 telescopic legs + tent



## PIATTO ABS (60x45cm)

ABS SIDE TRAY 60x45cm

CODE: PA0900A43H1

Piatto con 2 gambe telescopiche + tenda  
Tray with 2 telescopic legs + tent



## TENDA OXFORD

OXFORD TENT

**SOLD OUT**

ABS SIDE TRAY 60X45cm
ALUMINIUM SIDE TRAY 65X50cm
ALUMINIUM SIDE TRAY 52X40cm

## TENDA 240T-UV

240T-UV TENT

CODE	
PA0900A43H3	ABS SIDE TRAY 60X45cm
PA0900A43I3	ALUMINIUM SIDE TRAY 65X50cm
PA0900A43L3	ABS SIDE TRAY 52X40cm



## MODULO 2 CASSETTI FRONTALI

2 FRONTAL DRAWERS MODULE

CODE: PA0852

Misura cassetti - Drawers size: 29,5cm x18cm H.3,5cm



## MODULO 2 CASSETTI FRONTALI CON PORTA LENZE

2 FRONTAL DRAWERS AND LINE WINDER TRAY MODULE

CODE: PA0853

Misura cassetti - Drawers size: 29,5cm x18cm H.3,5cm



## MODULO RIBALTA PORTA LENZE

LINE WINDERS TRAY MODULE

CODE: PA0851



## COPERCHIO VALIGETTA

SLIDING BASE MODULE LID

CODE: PA0856



## MODULO 1 CASSETTO LATERALE

1 SIDE DRAWER MODULE

CODE: PA0854

Misura cassetti - Drawers size: 39,5cm x 27cm H.3,5cm



## MODULO 1 CASSETTO LATERALE CON PORTA LENZE

1 SIDE DRAWER WITH LINE WINDERS TRAY MODULE

CODE: PA0855

Misura cassetti - Drawers size: 39,5cm x 27cm H.3,5cm





# HI-TECH MODULES

## BASE VALIGETTA ESTRAIBILE

SLIDING BASE MODULE

CODE: PA0857



## SEDUTA IMBOTTITA

PADDED SEAT

CODE: PA0859



## CINTURA IMBOTTITA

SHOULDER STRAP

CODE: PA0906C



## GAMBE TELESCOPICHE Ø 30MM

LEGS

CODE	Length cm
PA0900A49	65
PA0900A48	55
PA0900A47	60
PA0900A48A	50



## MODULO H.40mm

MODULE H.40MM  
CODE: PA2012



## MODULO H.60mm

MODULE H.60MM  
CODE: PA2013



## MODULO H.80mm

MODULE H.80MM  
CODE: PA2014

2 Cassetti frontali - 2 *Frontal drawers*: 17x 27cm x H.3,5cm



## MODULO H.80mm

MODULE H.80MM  
CODE: PA2015

1 Cassetto laterale - 1 *Lateral drawer*: 25cm x 39cm x H.3,5cm



## SEDUTA IMBOTTITA

PADDET SEAT  
CODE: PA2018A

DYNAMO  
THUNDER  
HURRICANE



## SEDUTA IMBOTTITA

PADDET SEAT  
CODE: PA2019A

LEGEND SERIES



## LEGEND SERIES

BASE H.13cm  
CODE: PA2020



FRONT  
CODE: PA2021



BACK  
CODE: PA2022



**TRACOLLA**

SHOULDER  
CODE: PA2032A

**LEGEND  
SERIES**



**GAMBE**

LEGS

**TELESCOPIC LEGS / X FOOT**

CODE	Dimension	Description
PA2054	Ø30mm - H.65cm	Pedana Dynamo & Thunder Foot Plate Dynamo & Thunder
PA2055	Ø30mm - H.55cm	Gambe Frontali Dynamo & Thunder Frontal Legs Dynamo & Thunder
PA2056	Ø25mm - H.55cm	Pedana Legend Foot Plate Legend

**TELESCOPIC LEGS / COLMIC FOOT**

CODE	Dimension	Description
PA2056A	Ø30mm - H.65cm	Pedana Dynamo & Thunder Foot Plate Dynamo & Thunder
PA2056B	Ø30mm - H.55cm	Gambe Frontali Dynamo & Thunder Frontal Legs Dynamo & Thunder
PA2056C	Ø25mm - H.55cm	Pedana Legend Foot Plate Legend

**LEGS / X FOOT**

CODE	Dimension	Description
PA2058	Ø30mm - H.55cm	Gambe Posteriori Dynamo & Thunder Back Legs Dynamo & Thunder
PA2059	Ø25mm - H.50cm	Legend Light 7000 - PA2054 PA2055 - PA2056A - PA2056B
PA2061	Ø20mm - H.35cm	Pedana Legend Foot Plate Legend

**LEGS / COLMIC FOOT**

CODE	Dimension	Description
PA2062A	Ø30mm - H.55cm	Gambe Posteriori Dynamo & Thunder Back Legs Dynamo & Thunder
PA2062B	Ø25mm - H.50cm	Legend Light 7000 - PA2054 PA2055 - PA2056A - PA2056B
PA2062C	Ø20mm - H.35cm	Pedana Legend Foot Plate Legend

**LEG ROUND FOOT**

CODE	Dimension	Description
PA2060	Ø25mm - H.50cm	Legend Light 3000 - 5000

**EXTERNAL**

CODE	Dimension	Description
PA2063	Ø30mm - H.65cm	Pedana Dynamo & Thunder Foot Plate Dynamo & Thunder
PA2064	Ø30mm - H.55cm	Gambe Frontali Dynamo & Thunder Frontal Legs Dynamo & Thunder
PA2065	Ø25mm - H.55cm	Pedana Legend Foot Plate Legend

**PIEDINI**

FOOTS

CODE	Description
PA2052	for legs Ø25mm

CODE	Description
PA2049	for legs Ø30mm
PA2050	for legs Ø25mm
PA2051	for legs Ø20mm

CODE	Description
PA2052A	for legs Ø30mm
PA2052B	for legs Ø25mm
PA2052C	for legs Ø20mm



**ROUND FOOT**

A



**X FOOT**

B



**COLMIC FOOT**

C



Telescopic / X foot

Telescopic / COLMIC foot

legs / colmic foot

legs / X foot

leg round foot

EXTERNAL

EXTERNAL

## ONE SERIES - SEATBOXES

CODE	Description
PA0908B	Cavallotto poggia canna <i>Pole holder</i>
PA0900A64	Cerniera inferiore <i>Down drawer lock</i>
PA0900A63	Cerniera superiore <i>Upper drawer lock</i>
PA0900A57P	Panetto One per Gamba <i>Connector One</i>
PA0900A61	Pomello grande vite lunga per pedana <i>Big pommel long thread for platform</i>
PA0900A61A	Pomello grande vite corta per gambe <i>Big pommel short thread for legs</i>
PA0900A65	Galletto <i>Wing nut</i>
PA0900A62	Pomello piccolo per valigetta e seduta ONE <i>Small pommel for ONE seat and foldwey</i>
PA0430	Boccola in ottone (2pcs) <i>Brass bushing (2pcs)</i>
PA0422	Adattatore esterno per telaio e pedana <i>External adapter for module and footplate</i>
PA0427	Boccola in alluminio (2pcs) <i>Aluminium bushing (2pcs)</i>



PA0908B



PA0906A



PA0900A63



PA0900A64



PA0900A57P



PA0900A65



PA0427



PA0422



PA0900A61



PA0900A61A

## HURRICANE - DINAMO THUNDER - LEGEND

CODE	Description
PA2080	Pinza panetto per gamba Ø30mm <i>Plier for Ø30mm</i>
PA2081	Pinza panetto per gamba Ø30mm <i>Plier for Ø30mm</i>
PA0940A	Adattatore Uni-Star (20x20mm) SQUARE <i>Uni-Star adapter (20x20mm) SQUARE round</i>
PA0940B	Adattatore Uni-Star (25mm) ROUND <i>Uni-Star adapter (25mm) SQUARE round</i>
PA2073	Galletto Universale Ø30mm <i>Universal Screw Ø30mm</i>



PA2080



PA2081



PA2073



PA0940A



PA0940B

## HURRICANE - DINAMO THUNDER - LEGEND

CODE	Description
PA2030	Conchiglia per seduta nera <i>Pole holder for seat black</i>
PA2030A	Conchiglia per seduta nera/ rosa <i>Pole holder for seat black/ red</i>
PA2025	Paletto porta nassa <i>Keepnet holder</i>
PA2027	Cerniera moduli (maschio) <i>Module clip (male)</i>
PA2028	Cerniera moduli (femmina) <i>Module clip (female)</i>
PA2031	Ferma tracolla <i>Belt holder</i>
PA2032	Moschettone tracolla <i>Belt clip</i>
PA2033	Blocco rosso: piatto thunder <i>Thunder: side tray lock</i>
PA2047	Guida per pedana legend <i>Legend footplate: slider</i>
PA2046	Guida laterale per pedana Dynamo Thunder <i>Footplate slider: Dynamo and Thunder</i>
PA2039	Connettore in ABS per Legend 7000 e pedana Legend <i>ABS connector for Legend 7000 and footplat Legend</i>
PA2040	Blocco i ABS per connettore Ø 25mm <i>ABS block for connector Ø 25mm</i>
PA2041	Rondella in alluminio per connettore Ø 25mm <i>Aluminium plate for connector Ø 25mm</i>
PA2035	Connettore in ABS per Dynamo Thunder <i>ABS connector Dynamo and Thunder</i>
PA2036	Blocco in metallo per connettore Ø 30mm <i>Metal block for connector Ø 30mm</i>
PA2037	vite per connettore Ø 30mm <i>Screw for connector Ø 30mm</i>
PA2043	Bloccaggio gamba tele Ø 30mm <i>Block tele leg Ø 30mm</i>
PA2044	Bloccaggio gamba tele Ø 25mm <i>Block tele leg Ø 25mm</i>
PA2069	Pomello a piramide Dynamo Thunder <i>Pyramid pommel Dynamo Thunder</i>
PA2069A	Pomello a piramide per serie Legend <i>Pyramid pommel for Legend series</i>
PA2071	Galletto a triangolo per appoggia RBS laterale <i>Triangle screws for lateral pole rest</i>
PA2070	Galletto a triangolo per pedana Dynamo Thunder <i>Triangle screws for Dynamo Thunder footplate</i>
PA2067	Pomello <i>Pommel</i>
PA2068	Vite per gamba tele <i>Screw for telescopic leg</i>
PA2072	Galletto a triangolo per pedana Legend <i>Triangle screws for Legend footplate</i>



PA2030



PA2030A

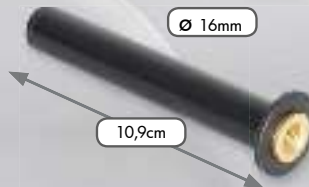

PA2025



PA2027



PA2028



PA2031



PA2032



PA2033



PA2047



PA2046



PA2039

PA2040

PA2041



PA2035

PA2036

PA2037



PA2043

PA2044



PA2069



PA2069A



PA2071



PA2070



PA2067



PA2068



PA2072

## KIT TRAINO UNIVERSALE PRO

UNIVERSAL TROLLEY KIT PRO

CODE: PA (SOLD OUT) A

RUOTE/ WHEELS  
CODE: PA0900A60A

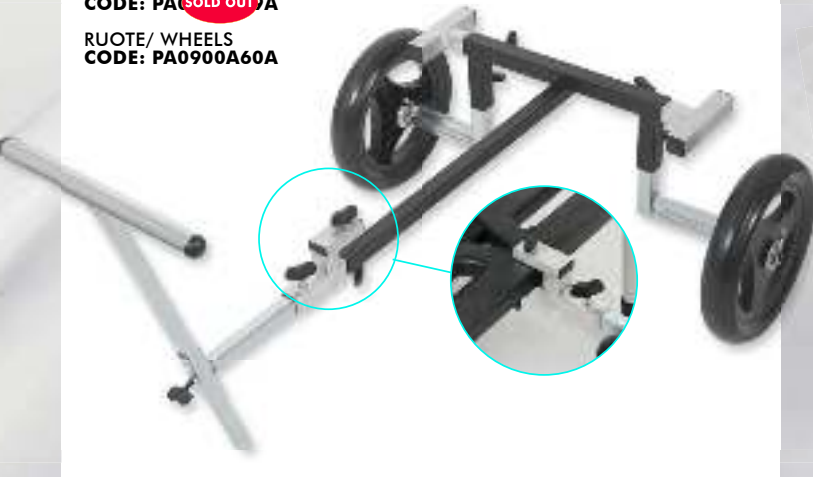

## KIT TRAINO PER HURRICANE

HURRICAN TROLLEY KIT

CODE: PA0900A59B



## MANICI PER KIT TRAINO

HANDLES FOR TROLLEY KIT

CODE: PA0900A59K



## KIT TRAINO PER ONE 2.0

ONE 2.0 TROLLEY KIT

CODE: PA0900A59C



## KIT TRAINO PER KROSS

KROSS TROLLEY KIT

CODE: PA0900A59D



## BARRA FRONTALE INCLINABILE

INCLINABLE POLE BAR

CODE: PA0960B



## BARRA FRONTALE INCLINABILE + NEOPRENE

INCLINABLE FRONTAL BAR + NEOPRENE

CODE	Neoprene cm
PA0960	50cm
PA0960A	45cm



## CONNETTORI INCLINABILI PER BARRE FRONTALI

INCLINABLE CONNECTORS FOR POLE BARS

Pack 2pcs - CODE: PA0961



## MAGIC POLE REST

CODE	Length cm
PA0407A	50cm



## PVC SEPARATOR

Pack 3pcs - CODE: PA0900A44B



## ADATTATORE UNIVERSALE

UNIVERSAL ADAPTOR

CODE: PA0940



**CONNETTORI**

CONNECTORS

CODE	Type	Length cm
PA2082A	ORIZZONTAL	15
PA2082B	ORIZZONTAL	25
PA2082C	90°	15



**CONNETTORE + PALETTO**

CONNECTOR WITH STAKE

CODE: PA2082



**ATTACCHI NASSA**

CONNECTOR KEEP NETS

CODE	Length cm
PA2090A	10
PA2090B	20



**BRACCO TELESCOPICO SNODATO 90°**

LONG TELESCOPIC ADJUSTABLE ARM 90°

CODE: PA2091





## APPOGGIA CANNA LATERALE

LATERAL POLE REST

Ø 30mm

CODE: PA0941

Ø 30mm

CODE: PA2024

## FERMA RBS ANTIVENTO

RBS WINDPROOF

CODE: PA0958

28-40cm

Ø 30mm

ADAPTOR  
Square Ø20  
Round Ø25

## CONNETTORE+ PALETTO

CONNECTOR WITH STAKE

CODE: PA0955

Ø 25mm

**SOLD OUT**

17cm

Ø 30mm

ADAPTOR  
Square Ø20  
Round Ø25

7cm

## CERCHIO IN ALLUMINIO

ALUMINIUM HOOP



CODE	Size
PA0900A38A1	Ø33cm Secchio / bucket 12lt Bacinella / basin 5lt
PA0900A38B1	Ø38cm Secchio / bucket 17lt Bacinella / basin 9lt
PA0900A38B2	Ø43cm Bacinella / basin 13lt

## CERCHIO IN ALLUMINIO

ALUMINIUM HOOP



CODE	Size
PA0900A38A	Ø33cm Secchio / bucket 12lt Bacinella / basin 5lt
PA0900A38B	Ø38cm Secchio / bucket 17lt Bacinella / basin 9lt

## BRACCI TELESCOPICI SNODATI 90°

UNIVERSAL LONG TELESCOPIC ADJUSTABLE ARM 90°

CODE	Length cm
PA0951	100+70
PA0946	47+20

ADAPTOR  
Square Ø20  
Round Ø25

100cm + 70cm

47cm + 20cm

**PORTA OMBRELLONI**

UMBRELLAS HOLDER

Code	Description
<b>A</b> PA2100A	Short: 19 cm
<b>B</b> PA2100B	Long: 30 cm
<b>C</b> PA2100C	Tele: 28,8 cm > 40 cm



**ROD REST**

Code	Description
<b>A</b> AP26A	Eva single rod rest: 22 cm
<b>B</b> AP27A	Eva double rod rest: 30 cm
<b>C</b> AP28A	Eva double rod rest: 38 cm
<b>D</b> AP29A	Eva triple rod rest: 40 cm
<b>E</b> AP30A	Eva angle rod rest: 22x28cm

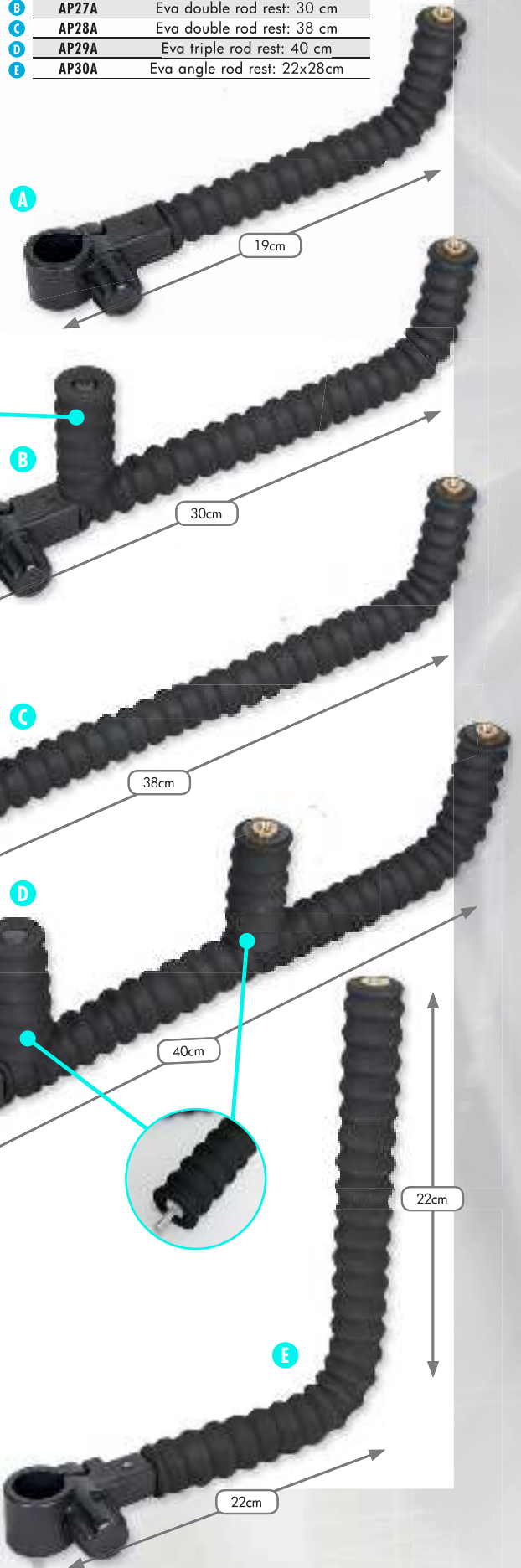

## APPOGGIA KIT & CANNE WAVE NEOPRENE

KIT & ROD HOLDER - WAVE NEOPRENE

CODE: PA0953



ADAPTOR  
Square Ø20  
Round Ø25



## APPOGGIA KIT LATERALE

KIT HOLDER SIDE 7 PLACES

Code	Size
PA0949	7
PA0950	10



ADAPTOR  
Square Ø20  
Round Ø25

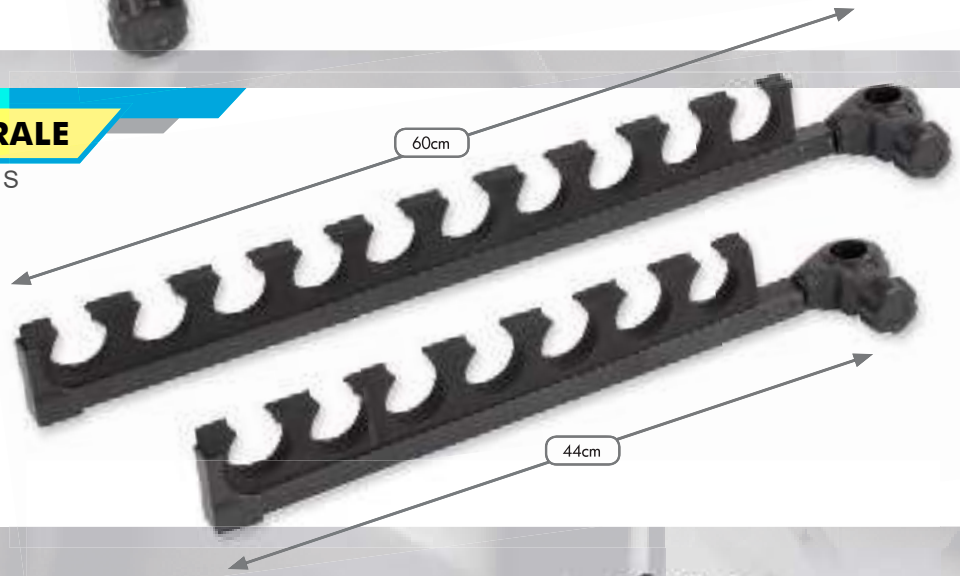

## APPOGGIA KIT BRACCIO SINGOLO 4 POSTI

SINGLE TOP KIT REST (4 PLACES)

CODE: AP001B

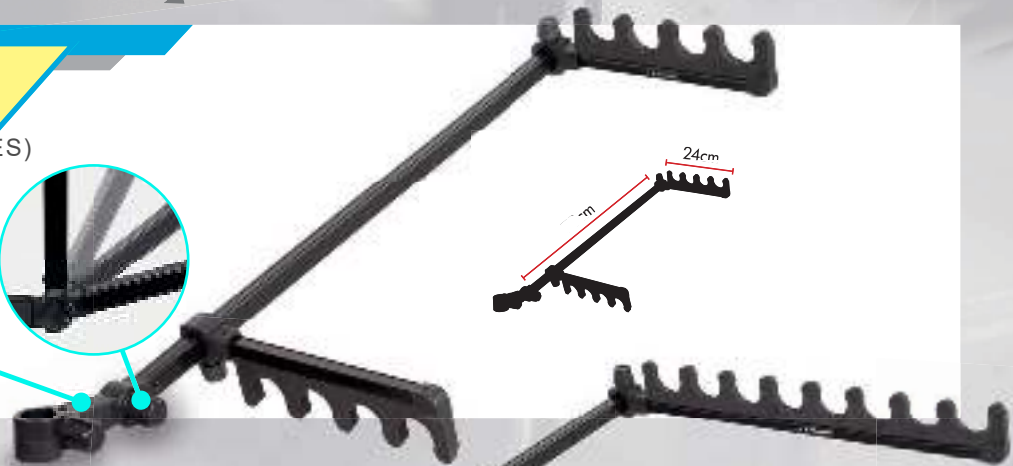
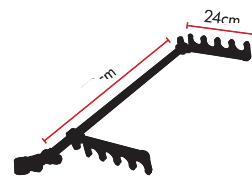

## APPOGGIA KIT BRACCIO DOPPIO 8 POSTI

DOUBLE TOP KIT REST (8 PLACES)

CODE: AP001A

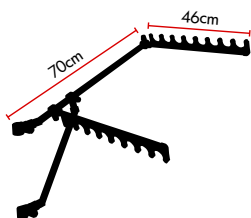

COMPETITION



**APPOGGIA KIT CON GAMBE:  
COMPETITION 12 POSTI**

TOP KIT REST WITH LEGS:  
COMPETITION 12 PLACES

CODE: AP00010

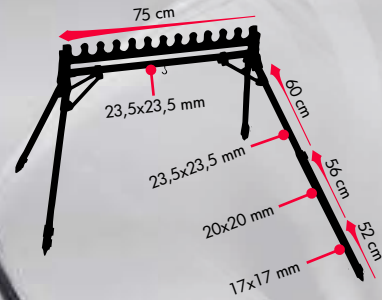

MATCH



**APPOGGIA KIT CON GAMBE:  
MATCH 12 POSTI**

TOP KIT REST WITH LEGS  
MATCH 12 PLACES

CODE: AP00011

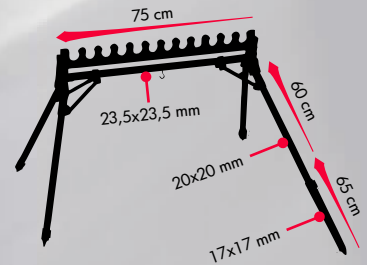

MATCH



**APPOGGIA KIT CON GAMBE:  
MATCH 12 POSTI (C/BATTUTA)**

TOP KIT REST WITH LEGS:  
MATCH 12 PLACES (W/BACK SIDE)

CODE: AP00012

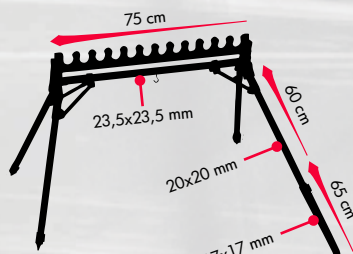

EASY



## APPOGGIA KIT CON GAMBE: EASY 9 POSTI

TOP KIT REST WITH LEGS:  
EASY 9 PLACES

CODE: AP00013

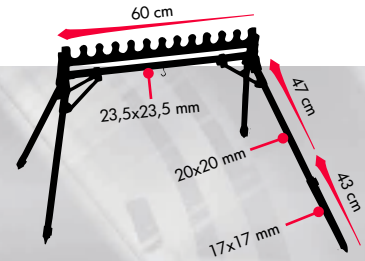

EASY

## APPOGGIA KIT CON GAMBE: EASY 9 POSTI (C/BATTUTA)

TOP KIT REST WITH LEGS:  
EASY 9 PLACES (W/BACK SIDE)

CODE: AP00014

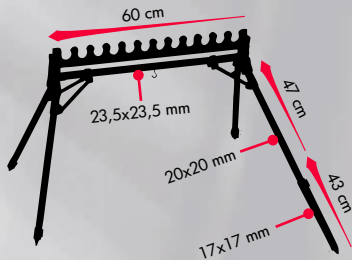

EASY

## APPOGGIA KIT CON GAMBE: EASY 12 POSTI

TOP KIT REST WITH LEGS:  
EASY 12 PLACES

CODE: AP00015

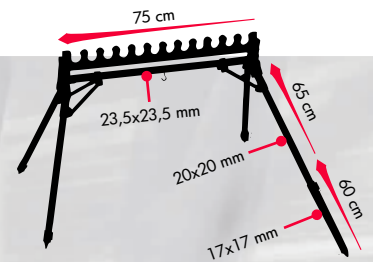

## APPOGGIA KIT CON GAMBE: EASY 12 POSTI (C/BATTUTA)

TOP KIT REST WITH LEGS:  
EASY 12 PLACES (W/BACK SIDE)

CODE: AP00016

EASY

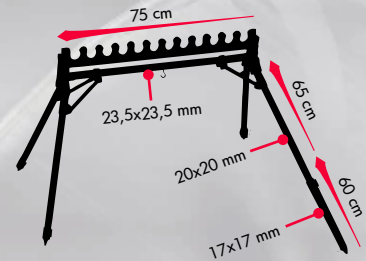

## APPOGGIA KIT CON GAMBE: PRO 9 POSTI

TOP KIT REST WITH LEGS:  
PRO 9 PLACES

CODE: AP00017

PRO

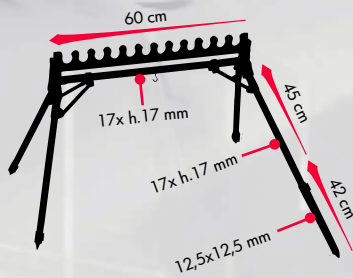

## APPOGGIA KIT CON GAMBE: PRO 9 POSTI (C/BATTUTA)

TOP KIT REST WITH LEGS:  
PRO 9 PLACES (W/BACK SIDE)

CODE: AP00018

PRO

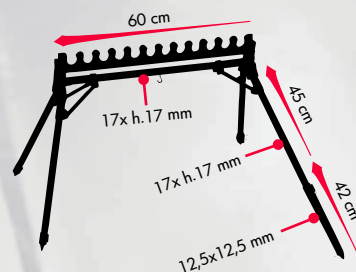

## ASTA TELESCOPICA A TRIVELLA

TELESCOPIC DRILL STAFF

CODE: AST01A 85-150cm



## APPOGGIA KIT

TOP KIT REST

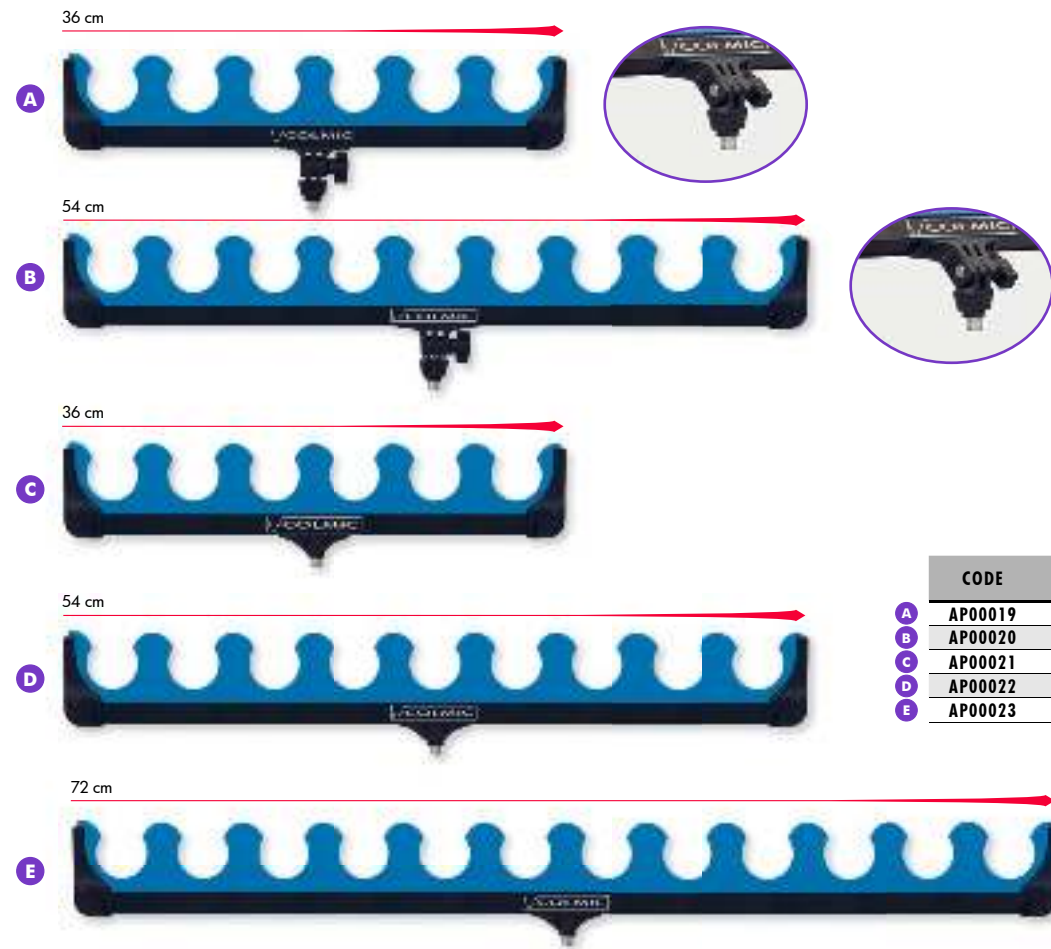

CODE	Description
<b>A</b> AP00019	6 Sections
<b>B</b> AP00020	9 Sections
<b>C</b> AP00021	6 Sections
<b>D</b> AP00022	9 Sections
<b>E</b> AP00023	12 Sections

## ROD REST WAVE

CODE: AP012



## ROD REST FLAT

CODE: AP011



## APPOGGIA CANNE SPEEDY

SPEEDY ROD REST

CODE	Description
<b>SOLD OUT</b> APSP3	Red Elastic



**APPOGGIA CANNE IN EVA**

EVA ROD REST

	CODE	Size
A	AP23A	9 cm
B	AP24A	30 cm
C	AP24B	48 cm



**ROLLER "V" 35CM  
EASY FOLDING**

CODE: RULAC3

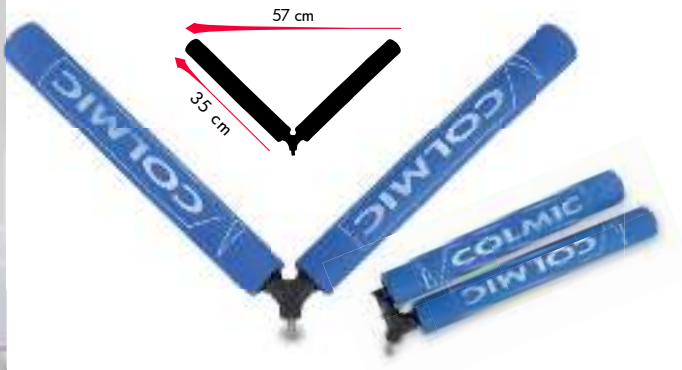

**ROLLER "V" 40CM  
RED SMALL ROLLER**

CODE: RULC3

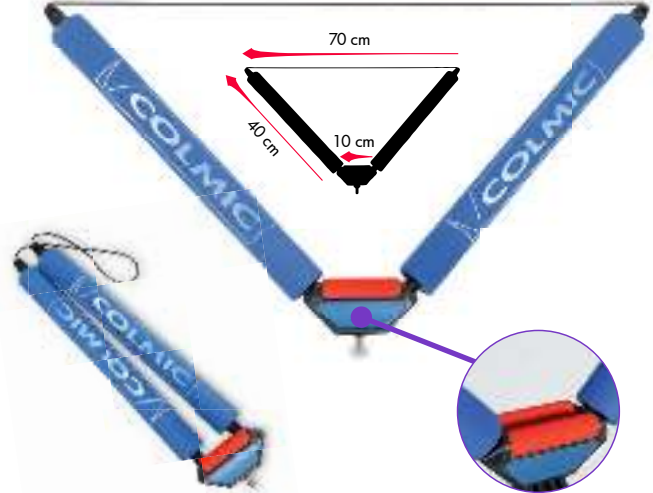



# BAR ROLLER

## BAR ROLLER OBLIQUE

CODE: RUL000

**SOLD OUT**

**SOLD OUT**

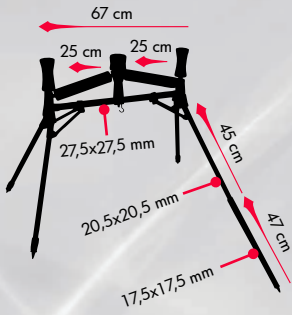

COMPETITION

## BAR ROLLER: COMPETITION 37cm + 37cm

CODE: RUL001

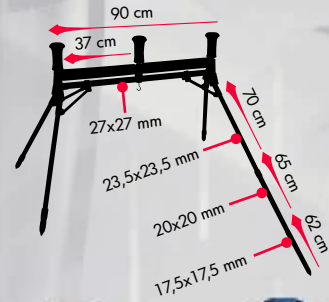

## BAR ROLLER: COMPETITION 30cm + 30cm

CODE: RUL002

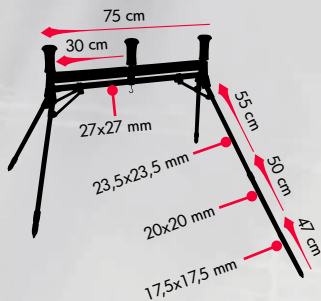

EASY & FAST

**BAR ROLLER:  
EASY & FAST 50CM**

CODE: RUL003

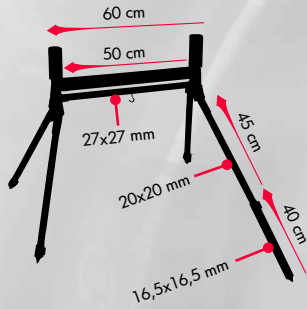

**BAR ROLLER  
RECO**

CODE: **SOLD OUT**

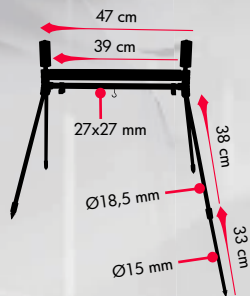

**BAR ROLLER  
15CM**

CODE: RVIO4



**BAR ROLLER  
23CM**

CODE: RVIO5

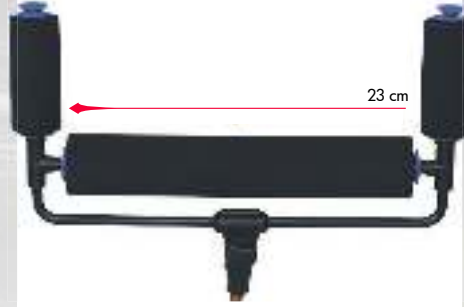

**RULLO DOUBLE**

CODE: RVIO6



# HIGH QUALITY



**"ELITE ROLLER"**  
 COD **SOLD OUT**



**ROD REST "BLUE FLASH"**  
 CODE: AP14

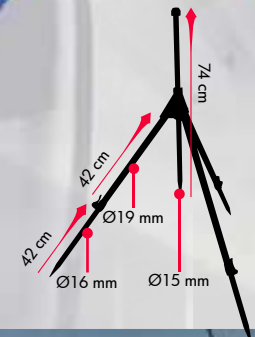

**ROD REST SEA ROFT TRIPOD**  
 CODE: AP013

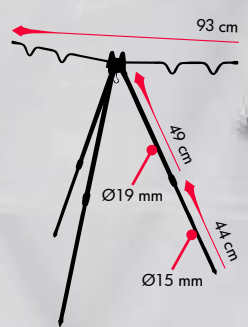
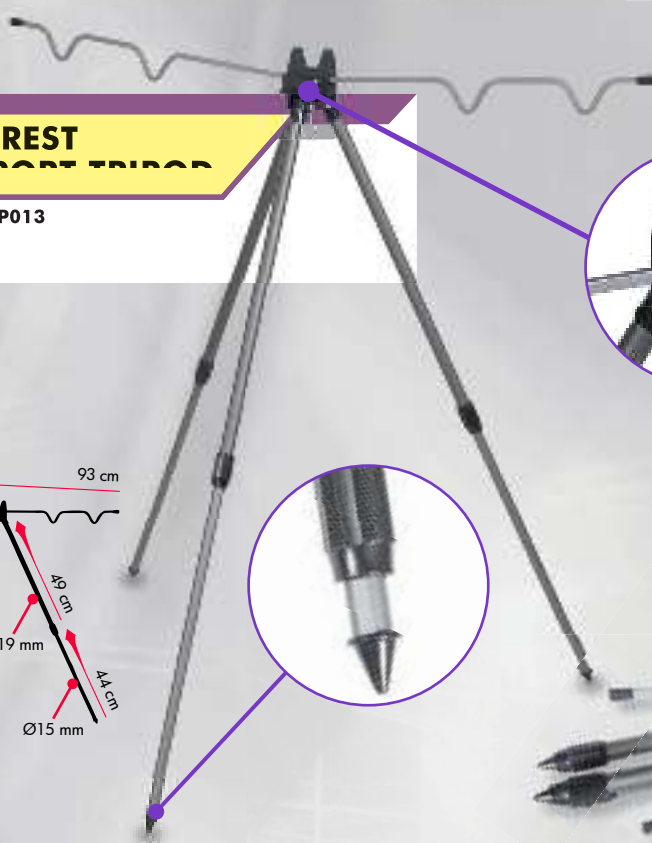

**TESSITURA RASCEL**
**MATERIALE IN POLIPROPILENE MISTO POLIETILENE 150GR/MQ**

Rete ideata e progettata per competizioni in canale e in fiume. Infatti, la rete di 150gr al metro quadro, è il perfetto compromesso tra leggerezza e resistenza, caratteristica che ogni Angler professionista richiede durante le competizioni. Rivestito in cordura sugli anelli per evitare qualsiasi danno dovuto all'usura. Speciale sagomatura del primo anello, studiata appositamente per garantire la minima distanza tra l'imboccatura della nassa e la gamba della pedana. Clip Press and Release System: meccanismo a scatti per la regolazione ottimale dell'inclinazione del primo anello. Clip Folding System: sistema di chiusura della nassa tramite delle clip a scatto inserite sul 1° ed ultimo cerchio, per riporla in maniera veloce ed ottimale nelle apposite borse.

**RASCEL WEAVE**
**MIXED POLYPROPYLENE/POLYTHENE MATERIAL 150GR/MQ**

*A mesh conceived and designed for competitions in canal and river. This mesh of 150 g per square metre is in effect the perfect compromise between lightness and strength, which is the characteristic that every professional angler is looking for during competitions. With Cordura sheathing on the rings to prevent damage due to wear. Special shaping of the first ring, specifically designed to keep the mouth of the keep net as close as possible to the leg of the footrest. Clip Press and Release System: snap mechanism for the perfect adjustment of the inclination of the first ring. Clip Folding System\*: system for closing the keep net using snap clips positioned on the first and last rings so that it can be replaced in the special bag as quickly and efficiently as possible.*

**KARPER**
**ROUND & SQUARED**

Tessitura Rascel Materiale 100% Polipropilene 175-205gr/mq

Adatte ad ogni tipo di pesca sono particolarmente resistenti e non permettono alle spine dei pesci di impigliarsi. Gli ultimi anelli sono dotati di un rivestimento in gomma per una maggiore protezione all'usura.

*Rascel weave - 100% Polypropylene material 175-205gr/mq*

*Suitable for all types of fishing are particularly resistant and do not allow the spines of fish to get caught. The last rings are provided with a rubber coating for extra protection against wear.*

**SQUARED**

1°Ring Aluminium Ø 10mm: 55cm x 45cm

Other Rings Steel Ø 4mm: 50cm x 40cm

Distance: 50cm

Press and Release

CODE	Rings
<b>SOLD OUT</b>	
NACR97E	9

**ROUND**

1°Ring Aluminium Ø 10mm: Ø 57cm

Other Rings Steel Ø 4mm: Ø 49cm

Distance: 50cm

Press and Release

CODE	Size	Rings
<b>SOLD OUT</b>		
NACR98E	4,00 MT	9

**RUBBER COVERED RINGS**



**PRESS AND RELEASE**



**CLIP FOLDING SYSTEM**



## RECORD

Progettata e studiata appositamente per la competizione e soprattutto durante le gare dedicate all'alborella o comunque a pesci di piccola taglia. Il primo anello (95x55cm) è stato progettato per avvolgere completamente la pedana del paniere. Un ulteriore aiuto, utile ad evitare perdite del pescato, è dato dall'aggiunta di un telo di trevira sul primo anello da fissare in vita come un semplice grembiule.

*Designed and studied specifically for competition fishing, and especially for bleak or small fish contests. The first ring (90x55 cm) has been designed so that it fits completely around the footrest of the seat box. A further aid to avoiding this type of loss of catch is provided by the addition of a sheet of Trevira fabric to the first ring, which is then fastened round the waist like a normal apron.*

1° Ring Aluminium Ø 10mm: 95cm x 55cm  
Other Rings Steel Ø 4mm : 35cmx45cm  
Distance: 40cm  
Press and Release

CODE	Size	Rings
NACR64	3,00 MT	7



**SOLD OUT**

## COMPETITION XT

Leggera, pratica e versatile, la Competition XT è caratterizzata da una forma semicircolare di tutti gli anelli, i quali favoriscono la distensione della nassa e la sua stabilità una volta adagiatasi alla sponda, anche in caso di forte vento laterale.

*In this model the special shape of the rings ensures that the keep net can be stretched perfectly on the ground without coiling over on itself. The shape of the first ring has been specially designed to keep the mouth of the keep net as close as possible to the leg of the footrest.*

1° Ring Aluminium Ø 10mm: 60cm  
Other Rings Steel Ø 4mm: 55cm  
Distance: 40cm  
Press and Release

CODE	Size	Rings
NACR64	3,00 MT	9

**SOLD OUT**



## REAL SQUARED RIVER

1° Ring Aluminium Ø 10mm: 55cm x 48cm  
 Other Rings Steel Ø 4mm: 45cm x 35cm  
 Distance: 40cm  
 Press and Release / Clip Folding System

CODE	Rings
NACR/35	10

**SOLD OUT**

## LAGO NEW XT

1° Ring Aluminium Ø 10mm: 55cm  
 Other Rings Steel Ø 4mm: 45cm  
 Distance: 40cm  
 Press and Release

Code	Size	Rings
NACR/35	10	6
NACR/35	10	10

**SOLD OUT**



**SOLD OUT**



**SOLD OUT**



## TESSITURA RASCEL MATERIALE IN POLIPROPILENE MISTO POLIETILENE 220GR/MQ

Rete ideata e progettata per competizioni alla Carpa. Infatti, la rete di 220gr al metro quadro, supplisce ad ogni esigenza di resistenza e robustezza, caratteristiche che ogni Angler professionista richiede durante le competizioni in carpodromo. Rivestito in cordura sugli anelli per evitare qualsiasi danno dovuto all'usura. Speciale sagomatura del primo anello, studiata appositamente per garantire la minima distanza tra l'imboccatura della nassa e la gamba della pedana. Clip Press and Release System: meccanismo a scatti per la regolazione ottimale dell'inclinazione del primo anello. Clip Folding System: sistema di chiusura della nassa tramite delle clip a scatto inserite sul 1° ed ultimo cerchio, per riporla in maniera veloce ed ottimale nelle apposite borse.

## RASCEL WEAVE MIXED POLYPROPYLENE/POLYTHENE MATERIAL 220GR/MQ

A mesh conceived and designed for carp fishing competitions. This mesh of 220g per square metre in effect meets all the requirements of strength and resistance that every professional angler is looking for during competitions in the carp fishery. With Cordura sheathing on the rings to prevent damage due to wear. Special shaping of the first ring, specifically designed to keep the mouth of the keep net as close as possible to the leg of the footrest. Clip Press and Release System: snap mechanism for the perfect adjustment of the inclination of the first ring. Clip Folding System\*: system for closing the keep net using snap clips positioned on the first and last rings so that it can be replaced in the special bag as quickly and efficiently as possible.

### REAL ROUND

1° Ring Aluminium Ø 10mm: Ø 60cm  
 Other Rings Steel Ø 4mm: Ø 55cm  
 Distance: 40cm  
 Press and Release  
 Clip Folding System

CODE	Rings
NACK64	10

**SOLD OUT**

### REAL SQUARED CARP

1° Ring Aluminium Ø 10mm: 55cmx45cm  
 Other Rings Steel Ø 4mm: 40cmx40cm  
 Distance: 40cm  
 Press and Release  
 Clip Folding System

CODE	Rings
NACK64	10

**SOLD OUT**

### CARPODROMO XT

1° Ring Aluminium Ø 10mm: Ø 57cm  
 Other Rings Steel Ø 4mm: Ø 43cm  
 Distance: 40cm  
 Press and Release

CODE	Rings
NACK64	10

**SOLD OUT**





## SUPER STRONG PISA

Tessitura Rascel Materiale 100% Polipropilene 300gr/mq

Con questa nassa abbiamo raggiunto il massimo che il mercato può richiedere da una rete Extra Strong. Infatti, il materiale di 300gr al metro quadro, dà a questa nassa la denominazione del campo gara "Pisa", dove le pesate del pesce raggiungono misure Extra Large! Da non dimenticare è che la rete, prodotto in 100% Polipropilene, fa sì che le spine del pesce non si attaccano alla rete.

Rascel weave - 100% Polypropylene material 300gr/mq

*With this keep net we have reached the apex of what the market can ask for from an extra-strong mesh. In effect, the 300 g per square metre material has earned this keep net the name of the "Pisa" competition venue, where the fish weigh in at distinctly Extra Large dimensions! Nor should we overlook the fact that the netting made of 100% Polypropylene delivers a wonderful additional feature, since the scales of the fish don't get caught up in the mesh.*

**SOLD OUT**

1° Ring: Ø 55cm  
Other Rings S: Ø 50cm  
Distance: 50cm  
Press and Release

**SOLD OUT**



## SPACE NET SQUARED

Tessitura Rascel, Materiale 100% Polipropilene 130gr/mq

Disponibile in 2 misure, 2,50 e 3 mt con rete ideata e progettata per ogni tipo di impiego, dalla carpa al pesce bianco. Le sue maglie, appositamente studiate per far sì che le spine dei pesci non si attacchino alla stessa, ci permettono di effettuare la fase di pesatura e di rilascio del pesce in maniera semplice e pratica. Anche questa nassa montana il dispositivo PRESS AND RELEASE SYSTEM per la regolazione ottimale della nassa in fase di pesca.

Rascel weave - 100% Polypropylene material 130gr/mq

*It is available in 2 sizes: 2,50 and 3 m with a mesh designed for any kind of use; from the carp to silver fish. Its mesh have been studied to not make the fish's spines get stuck to the net and permits the weighing and the releasing in a simple and practical way. It features the PRESS AND RELEASE SYSTEM for a better regulation while fishing.*

**SOLD OUT**

1° Ring: 52cmx42cm  
Other Rings: 46cmx37cm  
Distance: 50cm  
Press and Release







**SOLD OUT**

## NEW REVOLUTION

Tessitura Rascel, Materiale 100% Polipropilene 130gr/mq

Rete ideata e progettata per tutti i tipi di impiego, dalla carpa al pesce bianco con un ottimo rapporto qualità/prezzo. Anche su questo tipo di maglia le spine del pesce non si attaccano semplificando le operazioni di pesatura!

*Rascel weave - 100% Polypropylene material 130gr/mq*

*A mesh conceived and designed for multi-purpose use, from carp to white fish, which is also excellent value for money. The fish scales do not get caught up in this type of mesh either, greatly simplifying the weighing operations!*

CODE	Size	Rings
NACR96A	1,50	6
NACR96B	2,00	9
NACR96C	2,50	10

**SOLD OUT**

1°Ring: Ø 50cm  
Other Rings: Ø 45cm  
Distance: 50cm  
Press and Release

## START NET

Nassa pratica e robusta, realizzata in nylon intrecciato. Questo materiale, come noto, evita l'assorbimento di acqua, consente quindi una rapida asciugatura ed è facilissimo da sciacquare e riporre. Star Net, grazie alle sue dimensioni "ridotte" e alla qualità impeccabile, è adatta, sia per i pescatori inesperti, che per i professionisti. Ottima per chi pratica la pesca alla passata, ma anche per molteplici utilizzi in mare ed in acqua dolce.

*Practical and robust nets, made of braided nylon. This material, as known, prevents the absorption of water, therefore allows a rapid drying and make it easy to rinse and to store. Star Net, thanks to its "small" size and its impeccable quality, it's suitable for inexperienced fishermen and professionals. Excellent for those who fish in flowing waters but also for multiple uses in the sea and in fresh water.*

CODE	Size	Rings
NACR97A	1,50	5
NACR97B	2,00	6

1°Ring: Ø 39cm  
Other Rings: Ø 35cm  
Distance: 60cm



## KILOS NET

Speciale rete per la pesatura del pescato realizzata con maglia in cotone DRY-MESH inodore una volta riposta. Dotata di un telaio con apertura a libro e due maniglie in plastica dura, è pratica e di veloce utilizzo.

*Special net for weighing the catch made of water-repellent DRY-MESH smell-free cotton which spells no lingering bad odours even when it is put away. It has a frame that opens like a book, two handles in hard plastic and is practical and quick and easy to use.*



CODE	Size cm	gr.
GUZH07A	45X50	400

SIZE (MM)

**6**





## ROYAL CARP

La rete usata per queste due teste è da definirsi quanto di meglio si possa trovare nel mercato per l'uso alle carpe. Disponibili in due misure, Royal Carpa -08 e Royal Carpa-15. Il nylon bordeaux che avvolge l'alluminio della testa, oltre che dare un bel look all'oggetto, è estremamente utile come proteggi rete in fase di recupero del pesce.

*The mesh used for these two landing-net heads can justly be described as the very best to be found on the market for use with carp. Available in two sizes: Royal Carpa-08) and Royal Carpa-15). The burgundy nylon that covers the aluminium of the head is not only attractive but also extremely useful for protecting the net in the fish retrieval phase.*

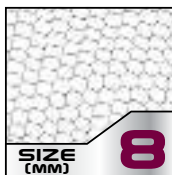

### ROYAL CARP 08

Code	Size cm	gr.
GUROY01	Ø 40	180
GUROY02	Ø 47	195
GUROY03	Ø 55	220

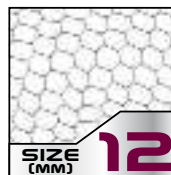

### BOTTOM

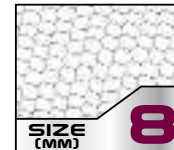

### ROYAL CARP 15

CODE	Size cm	gr.
GUROY04	Ø 40	175
GUROY05	Ø 47	190
GUROY06	Ø 55	210



## ROYAL NYLON 06

La ROYAL NET è caratterizzata da una leggerezza veramente fuori dal comune. I due modelli che vanno a comporre la serie, sono entrambi assemblati con rete IDRO in nylon 100% di primissima qualità.

*The ROYAL NET is characterised by a lightness that is truly out of the ordinary. The two models that make up the series are both fitted with prime-quality 100% nylon HYDRO mesh.*



Code	Size cm	gr.
GUROY07	Ø 40	155
GUROY08	Ø 47	185





6,95MM



## LIGHTECH BREME & GARDON

Le caratteristiche principali di queste teste sono appunto il suo telaio in lega ultralight abbinato alla speciale rete in cotone DRY-MESH impermeabile 100% la quale non assorbendo acqua, rimane sempre maneggevole durante la fase di guadatura e una volta riposta, non trattiene cattivi odori.

*The main features of these heads are the frame in ultralight aluminium combined with the special net of 100% water-repellent DRY-MESH cotton, which does not absorb water and hence remains manageable during the landing phase and does not retain bad smells when it is put away.*

### LIGHTECH GARDON

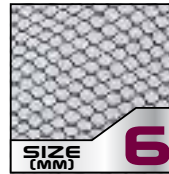

SIZE (MM) **6**

### LIGHTECH BREME

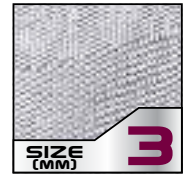

SIZE (MM) **3**

CODE	Size cm	gr.
GUZH01A	45X55	125
GUZH01B	40X45	105

Code	Size cm	gr.
GUZH02A	45X55	110
GUZH02B	40X45	125

## SUPER LIGHT FRAME

### FAST

Testa di guadino super leggera, prodotta con rete IDRO in nylon 100%. Questa rete si distingue per il minimo attrito con l'acqua e non ne assorbe. Inoltre, si sporca difficilmente, è facile da pulire e non lascia cattivi odori una volta riposta. Maglia 6mm.

*Extremely light landing net, produced with 100 % nylon HYDRO net. The main features of this net are the minimal friction with the water and it non-absorbance. In addition, it gets dirty with difficulty and it is easy to clean and leaves no smells. 6 mm mesh.*

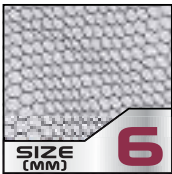

**SOLD OUT**

SIZE (MM) **6**



**SOLD OUT**

### NYLON 45X35

Testa di guadino con sacco di forma particolarmente adatta a guadagnature in velocità, la forma del sacco favorisce inoltre la manipolazione del pesce che rimarrà più fermo una volta estratto dall'acqua; la rete nylon non assorbe acqua ed è di conseguenza più leggera e maneggevole, le maglie larghe favoriscano la manovrabilità in acqua.

*Landing net head featuring a special shape for fast scooping, the special shape of the net will make fish handling easier and will keep fish calmer during the hook removal process; the nylon net will not rinse water and is consequently lighter and more maneuverable, the large mesh will easily move trough water.*

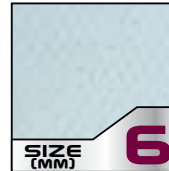

SIZE (MM) **6**

CODE	Size cm	gr.
GUHJ01A	45X35	140

### OVAL BOTTOM



## VELOX MESH

Testa di guadino progettata da Colmic per la pesca da competizione in acque libere e nelle commercial fisheries. Costruita con una struttura in alluminio sottile ed un attacco a vite molto robusti. Il profilo della rete è rotondo e non troppo profondo per una comoda accessibilità alla preda in fase di slamatatura ed è caratterizzato da un diametro della rete variabile: sul fondo della testa è molto fine, per non disturbare il pescato eccessivamente e prevenire che gli hair rig ed i pellets si incastrino nelle spire, mentre sui lati il diametro è maggiore per ridurre la resistenza dell'acqua e favorire la guadatura in velocità del pescato.

*Landing net head made specifically with commercial venues in mind. It has a light but strong aluminium frame mounted on a robust screw connector. The profile of the net is shallow and rounded for easy access to the captured fish and employs two grades of mesh size. The mesh in the bottom of the net is ultra fine so as not to disturb the fish too much and also prevents hair rigs from getting tangled and breaking, the side mesh is of a larger size and reduces resistance in the water when 'scooping' the fish.*



CODE	Size cm	gr.
GUHJ04A	45X35	150
GUHJ04B	50X40	170



## AQUALITY

La testa AQUALITY è composta da una doppia rete in cotone DRY-MESH impermeabile 100%, più fitta sui lati, con il fondo a rete più larga per facilitare l'operazioni di guadatura della preda e grazie ai due neopreni situati sulla struttura, ci permette di ottimizzare al meglio i movimenti in acqua. Anche la testa AQUALITY, grazie alla speciale rete DRY-MESH, non assorbe acqua e non lascia cattivi odori una volta riposta.

*The AQUALITY net head is made of a double net of 100% water-repellent DRY-MESH cotton, with finer mesh at the sides and larger on the bottom to facilitate landing operations; the two neoprene inserts set on the frame make it possible to optimise movement in the water. In view of the special DRY-MESH net, the AQUALITY head does not absorb water and so it does not retain bad smells when it is put away.*

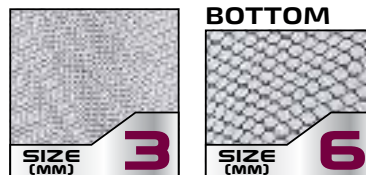

CODE	Size cm	gr.
GUZH03A	45X50	195



## MAX COMBAT

Testa di guadino ideata per grosse prede dalla forma rettangolare. Anche per questo modello viene utilizzato il telaio in speciale lega ultraleggera e indeformabile, abbinando la rete DRY-MESH impermeabile 100% antiodore. Ideale per il carpodromo, ma anche per le competizioni in fiume dove le grosse prede risultano essere numerose. I due neopreni situati sul telaio, ci permettono una maggiore velocità di movimento in acqua.

*Square-shaped landing-net head designed for large prey. For this model too, the frame is made from a special ultra-light, non-deformable alloy and the net is 100% water-repellent DRY-MESH smell-free cotton. It is ideal for use in the carp fishery, but also for competitions in the river where the big prey are numerous. The two neoprene inserts on the frame allow the net to move more swiftly through the water.*



CODE	Size cm	gr.
GUZH04A	55X65	260

# GUMMA NET

## RUBBER MATCH

Del tutto innovative nella loro struttura, le RUBBER MATCH hanno come caratteristiche principali, la leggerezza e la praticità d'uso. Infatti, considerando la completa gommatura della rete, i 220 gr per la misura più grande, ed i 185 gr per quella più piccola, sono veramente da considerarsi un record per questa categoria di prodotti. La rete gommata è totalmente idrorepellente, oltre che a prevenire i fastidiosi odori del post pesca, evita l'altrettanto sgradito incaglio dei piombi durante la fase di recupero del pesce.

*These RUBBER MATCH landing nets have an absolutely innovative structure. They are light and easy to use. Considering that the whole net is rubberized, the bigger size weighs only 220gr while the smaller size weighs 185 g. The rubberized net is totally water-repellent, and besides preventing annoying post fishing odours it equally helps avoid hooks and shots from getting tangled during the fish recovery.*

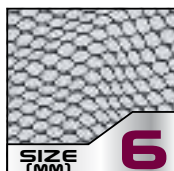

CODE	Size cm	gr.
GUZH08A	45X55	225
GUZH08B	40X45	210



## TOP GUM

La rete realizzata in materiale gommato, è formata da due tipi di maglia. La maglia gommata sui lati è più larga per una minor attrito in acqua, rendendola di una manovrabilità eccezionale, mentre il fondo della testa è dotato di rete gommata più fine, in modo da evitare che una volta guadagnata la preda, i nostri pallini o torpille si intreccino alla maglia stessa. Ideale per le competizioni dove c'è la necessità di guadagnare grosse prede in minor tempo possibile.

*The rubberised net includes two types of mesh: the rubberised mesh at the sides is larger so as to reduce friction with the water, making it exceptionally easy to manoeuvre, while the bottom of the net is made from finer rubberised mesh so as to avoid our olivettes or shot getting tangled up in the mesh once the prey is in the net. It is perfect for competitions, where big prey have to be netted as quickly as possible.*

CODE	Size cm	gr.
GUZH06B	50X60	330

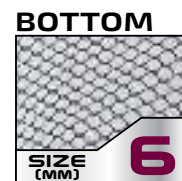
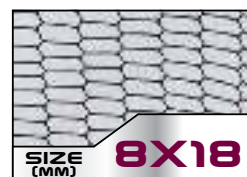

## HIPER GUM

La caratteristica della HIPER GUM è la sua rete realizzata in materiale gommato e quindi indistruttibile. Ideale per grosse prede, per il carpodromo e per le competizioni come l'arno pisano, dove occorre una maglia nella quale non si impigli le spine dei grossi gatti presenti e al tempo stesso affidabile e indistruttibile. Dotata di due neopreni sul telaio, ci permette una maggiore ed una più fluida manovrabilità in acqua.

*The most striking feature of the HIPER GUM is the net made of rubberised and hence indestructible material. It is ideal for big prey, for the carp fishery and also for competitions such as the Pisan Arno, where you need a net in which the scales of the big catfish present don't get entangled, while at the same time the net has to be reliable and indestructible. The two neoprene inserts on the frame allow the net to be more fluidly manoeuvred in the water.*



CODE	Size cm	gr.
GUZH05A	45X55	330



## BENT



TESTE DI GUADINO - LANDING NET HEADS



SECTION



## MATCH GOLD

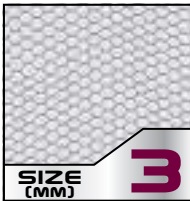

SIZE (MM) **3**

CODE	Size cm	gr.
<b>GU00XT01</b>	45X35 NET-IN	220
<b>SOLD OUT</b>	50X40 NET-IN	230

## MATCH SILVER

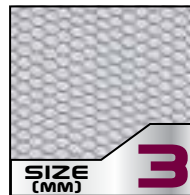

SIZE (MM) **3**

CODE	Size cm	gr.
<b>GU00XT04</b>	45X35 NET-OUT	210
<b>SOLD OUT</b>	50X40 NET-OUT	225
<b>SOLD OUT</b>	55X45 NET-OUT	245

## SLIDER NYLON

Testa di guadino per la competizione, prodotta in morbido monofilo di nylon con minimo attrito all'acqua, ideale in casi di molte catture; leggera, di rapida asciugatura. La forma a cucchiaio del telaio facilita l'entrata del pesca nella testa.

*This is a landing-net head conceived for competition fishing, made from monofilament nylon so that it has minimal friction with the water, perfect in the case of multiple catches, light and quick-drying. The frame is specially designed in a spoon shape to make it easier for the fish to enter the head.*

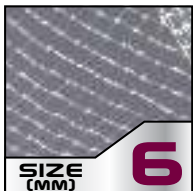

SIZE (MM) **6**

CODE	Size cm	gr.
<b>GUNYL01</b>	45X40	145



## SUNSET NATURAL

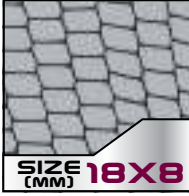

SIZE (MM) **18X8**

### BOTTOM



SIZE (MM) **8X4**

CODE	Size cm	gr.
GUNAT01	57X47	214
GUNAT02	65X55	223



## SUNSET GUMMA

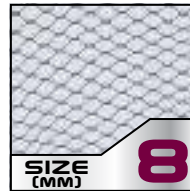

SIZE (MM) **8**

### GUMMA NET

Code	Size cm	gr.
GUGUM01	45X35	200
GUGUM02	50X40	232
GUGUM03	57X47	238

## HYDRO 070

Cerchio ovale in alluminio e rete in monofilo di nylon diametro 0.70mm per evitare che l'amo si incagli nel tessuto. Ideale per il carpo dromo e per il mare specialmente per la pesca dalla scogliera per limitare il logorio dovuto allo sfregamento sugli scogli.

*Oval landing-net head in aluminium with mesh in monofilament nylon, of a diameter of 0.70 mm to prevent the hook getting snagged in the fabric. Ideal for the carp fishery and for the sea, especially for fishing from rocks, since it reduces the wear due to rubbing on the rocks.*

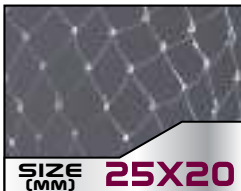

SIZE (MM) **25X20**

CODE	Size cm	gr.
GUST46C	40X46	113
GUST55D	50X55	132



**PREMACY**

Testa di guadino con struttura ovale e rete in tessuto a trama "Rascal" in poliestere 100% di colore nero.

Oval landing-net head with black mesh in "Rascal" weave 100% polyester fabric.

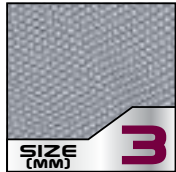

CODE	Size cm	gr.
GUST55B	50X55	175



**NATURAL NET**

CODE	Size cm	length	gr.
GUHAN02	35X45	67CM	295

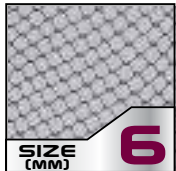

**MAGNETIC RELEASE**



Caratteristica di questo manico di guadino è il materiale, un tessuto trecciato e gommato che permette una rapida asciugatura. La rete gommata è utilissima come anti incaglio per gli artificiali o ami in genere. Il manico è dotato di un sistema magnetico di sgancio che permette un rapido uso. Indispensabile per la pesca in torrente.

*The most distinctive feature of this landing-net head is the material it is made from. This is a specially woven and rubberised fabric that allows it to dry extremely rapidly. In addition, the rubberised mesh is extremely useful for preventing artificial lures, or hooks in general, getting snagged. It's an indispensable object for fishing in the stream.*



**GUMMA NET**

CODE	Size cm	length	gr.
GUHAN01	45X35	67CM	295

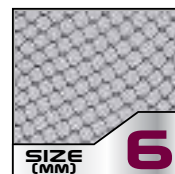

**GUMMA NET**



## BASS NET

Il guadino che tutti vorrebbero, leggero resistente, pratico e maneggevole. Il manico e la testa a pera sono realizzati completamente in leggerissimo alluminio. La vera innovazione è la rete in PVC, studiata per essere la più leggera ed idrodinamica sul mercato. La PVC transparent net oltre ad essere leggera è pensata per salvaguardare il pesce durante la cattura, risultando ottima per gli agonisti e per tutti coloro che praticano il catch&release.

*The landing net that everyone would have: light but resistant, practical and manageable. The handle and the pear-shaped head are entirely made of lightweight aluminium. The real innovation is the PVC net, designed to be the lightest and most hydrodynamics on the market. Lightness is not the only features of this PVC transparent net, that has been especially designed to safeguard the fish during the capture, resulting excellent for the competitor and for all those who practice catch and release.*



SIZE (MM) **20X25**

CODE	Size cm	length
GUHAN05	50X45	85CM



## TOURNANET 70CM

Quando si desidera fare spinning con una barca è necessario gestire una grande quantità di materiale in piccoli spazi. Il Tournanet è la risposta a queste esigenze. Questo leggero guadino interamente in alluminio con manico telescopico e rete gommata è perfetto per i tornei di bass fishing e per tutte le uscite di pesca dalla barca.

*While fishing from a boat you need to manage a large amount of equipment in a small spaces. The Tournanet is the answer to your needs. Extremely light telescopic aluminium landing net with rubber mesh. It's perfect for bass fishing tournaments and general boat fishing.*

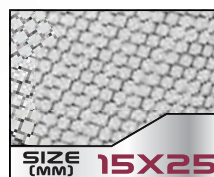

SIZE (MM) **15X25**

CODE	Size cm	length
GUHAN03	48X45	70CM

## TOURNANET 90CM

La versione più grande del Tournanet, leggero, resistente, pratico e dotato della stessa rete gommata di alta qualità. Il manico, la testa e il raccordo sono realizzati completamente in leggerissimo alluminio per resistere al peso dei pesci di grossa taglia.

*The bigger version of the Tournanet: light, durable, practical and with the same high quality rubberized net. The handle, the head and the connector are made entirely of resistant and light aluminium, in order to withstand the weight of large fish.*

CODE	Size cm	length
GUHAN04	60X55	90CM



SIZE (MM) **5X8**

**2,50MT**
**2,80MT**
**3,10MT**

CODE	Size Ø mt	POLE ANGLE
OMH10A	2,20	-
OMH10B	2,50	V
OMH10C	2,80	V
OMH10G	3,10	V

**2,20MT**
**TRASPIRABILE**
**UV  
PROTECTION**
**WATER PROOF**
**HIGH TECH 240T-UV**

## FIBERGLASS UMBRELLA

Indistruttibili, versatili e innovativi. Sono queste le tre parole d'ordine scelte da Colmic per la nuova serie di ombrelloni.

**INDISTRUTTIBILI:** grazie alle robustissime stecche in fibra di vetro da 8 mm., capaci di far fronte alle più forti sollecitazioni; al telo impermeabile di copertura in tessuto HIGH TECH 240T-UV, assemblato con cuciture rinforzate e termosaldate; ai tre anelli d'ancoraggio fissati alla calotta; al palo d'acciaio munito di trivella e allo snodo dentellato in alluminio cromato, unico sul mercato.

**VERSATILI:** grazie al materiale di costruzione della calotta impermeabile, perfettamente in grado di resistere alla pioggia più intensa e allo stesso tempo di evitare il terribile "effetto serra" delle torride sessioni estive, scongiurato dalla "traspirazione unidirezionale" del tessuto che garantisce la circolazione dell'aria e la conseguente dispersione del calore imprigionato sotto la cupola.

**INNOVATIVI:** grazie all'impegno dei tecnici Colmic che hanno messo a punto materiali e componentistica all'avanguardia, fino a creare un prodotto unico e ineguagliabile, mai visto prima d'ora sul mercato.

**QUINDI:** stecche in fibreglass da 8 mm., palo in acciaio munito di trivella, telo di copertura impermeabile e traspirante, tre anelli di ancoraggio con relativi picchetti e corde, snodo dentellato in alluminio cromato.....riassumendo il tutto in poche parole: "oltre il meglio".

*Durable, versatile and innovative. These are the three words to describe the new Colmic brolleys.*

*DURABLE: thanks to the 8 mm fiberglass ribs, able to stand the more extreme situations; to the waterproof HIGH TECH 240T-UV shell, assembled using reinforced thermo welded sewings; to the three anchoring rings connected to the outer shell; to the steel drill point pole and the chromed aluminium dented lock joint, the only on the market today.*

*VERSATILE: thanks to the manufacturing material of the outer shell, heavy rain proof and in the same time to the terrible summer days heat, thanks to the unidirectional transpiring featuring of the fabric, guaranting the air flow under the shell and the heat dissipating effect.*

*INNOVATIVE: thanks to the commitment of the Colmic technicians using the latest materials and components, to obtain a unique and unmatched product never seen on the market until today.*

*FINALLY: 8 mm fiberglass ribs, drill point steel pole, waterproof and breathable outer shell, three anchoring ringed point and related pegs and cords, chromed aluminium dented lock joint ..... In a few words: "over the top".*

# HIGH QUALITY

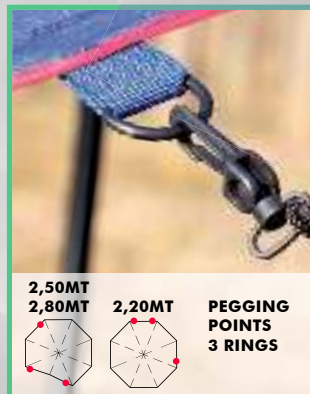
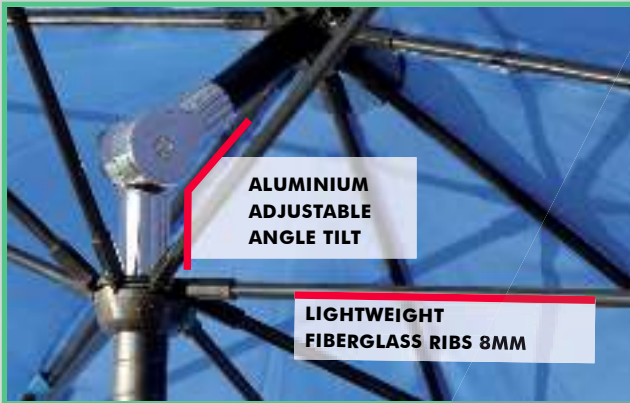

## TREND FIBERGLASS UMBRELLA

CODE	Size Ø mt
OMH11A	2,20
OMH11B	2,50

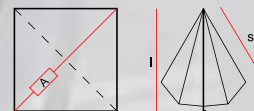

## OMBRELLONE DA ESCE QUADRATO IN PVC

SQUARED PVC BAIT UMBRELLA

CODE	Size mt	L mt	A mt	S mt
OMH12A	0,90x0,90	1,00	1,25	0,70

## SEDIA RIPIEGABILE

FOLDING CHAIR  
CODE: SGC08



## SEGGIOLINO CON BORSA

FOLDING SEAT WITH BAG  
CODE: SGC07



## SEGGIOLINO CON ZAINO E APPOGGIA CANNE

FOLDING SEAT WITH BACKPACK AND POLE REST  
CODE: SGC06



## CESTELLI PORTATROTE

TROUT HOLDER  
CODE: SACC09

## SGABELLO IN FERRO

IRON STOOL  
CODE: SGC04

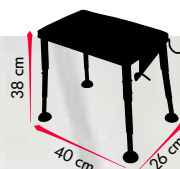



- + NEW DESIGN
- + NEW MATERIAL
- + HIGH RESISTANCE
- = HIGH PERFORMANCE

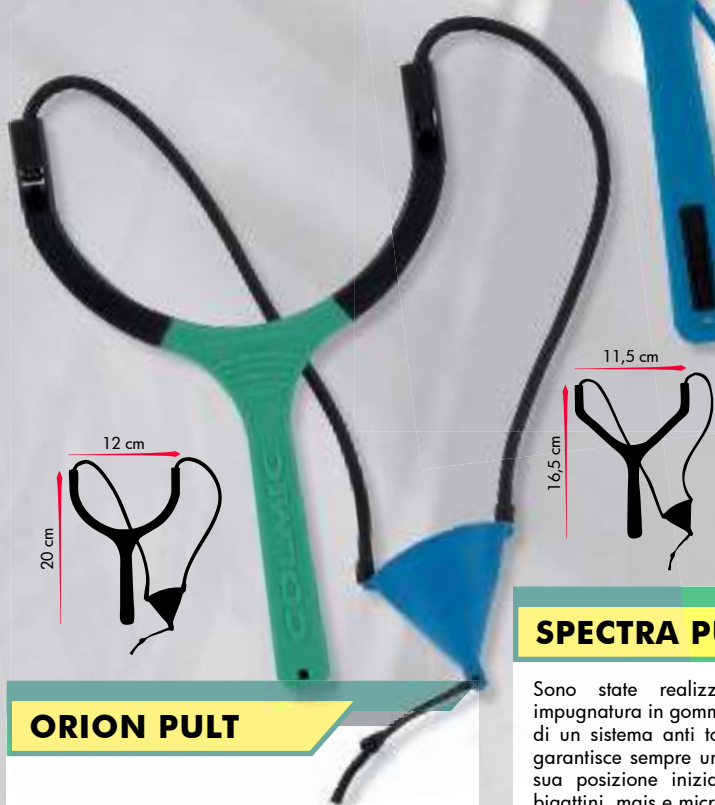

## ORION PULT

Le ORION si distinguono per una dimensione del bicchiere più ampia, e quindi sono consigliate per il lancio di esche sfuse, impastate o incollate, a media distanza.

*The ORION catapults have a larger-sized pouch and are suitable for medium-range casting of loose groundbait or sticky bait.*

CODE	Color	Soft Pouch	Elastic ø mm	gr.
FNCQ03	Green	2	4,50 Black	51,0
FNCQ031	Green	3	4,50 Black	51,0
FNCQ03A	Red	3	5,00 Black	54,5

## SPECTRA PULT

Sono state realizzate con una particolare impugnatura in gomma anti scivolo e sono dotate di un sistema anti torsione dell'elastico, il quale garantisce sempre un ritorno del medesimo nella sua posizione iniziale. Ideale per il lancio di bigattini, mais e micro pellet.

*The features a special handle made of non-slip rubber plus a system that prevents the elastic getting twisted, so that after the cast it always returns to rest in the same position. Perfect for casting maggots, corn and micro pellets.*

CODE	Color	Soft Pouch	Elastic ø mm	gr.
FNCQ01	Red	1	3,00 Red	33,5
FNCQ011	Blue	2	3,00 Red	33,0
FNCQ01A	Red	1	4,00 Blue	33,0
FNCQ01B	Blue	2	4,00 Blue	33,5
FNCQ01C	Blue	3	4,00 Blue	33,5

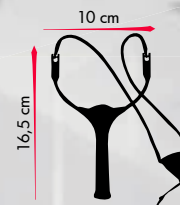

## LEGEND PULT

Una fionda ultra leggera, con un manico prodotto in materiale gommato antiscivolo ed un innovativo sistema a cuscinetti, che annulla completamente le fastidiose torsioni dell'elastico. Dopo ogni fiondata, il cestello torna sempre nella sua posizione originaria, evitando così la perdita di tempo nel riposizionarlo per un nuovo lancio. Davvero l'ideale per bigattini, mais e pellet.

*An ultra-light catapult, with a handle in rubberised non-slip material and an innovative ball-bearing system that completely eliminates annoying twists of the elastic. After every cast the pouch returns to its original position, so that you don't have to waste time repositioning it for a new shot. It is absolutely perfect for maggots, corn and pellets.*

CODE	Color	Soft Pouch	Elastic ø mm	gr.
FNCQ02	Green	1	3,00 Red	32,5
FNCQ021	Green	2	3,00 Red	33,0
FNCQ02A	Red	1	4,00 Blue	33,0
FNCQ02B	Blue	2	4,00 Blue	35,5

# DEVIL PULT SERIES

Tutte le serie delle Devil Pult sono caratterizzate da un'impugnatura ergonomica in gomma anti scivolo e da un particolare profilo inclinato che agevola tutta la procedura di lancio.

*The entire Devil Pult series features ergonomic handle in non-slip rubber and a special sloped shape that makes casting even easier.*



**RUBBER  
MESH  
POUCH**

## DEVIL PULT GROUND BAIT

Questa fionda è stata realizzata appositamente per il lancio di grosse palle di pastura o di bigattini incollati. Il cestello è in gomma stampata, con fori d'alleggerimento.

*This catapult has been specially designed for casting large groundbait balls or sticky maggots. The pouch is made of moulded rubber, pierced to make it lighter.*

CODE	Color	Elastic ø mm	gr.
FNCQ04	Green	6,00 green	93,5
FNCQ04A	Red	7,00 Black	96,5



## DEVIL PULT MAGGOTS

Ideata per il lancio di precisione di palle di bigattini e bigattini sfusi in discrete quantità. Infatti, l'esclusivo cestello in gomma stampata e gli elastici da 5 mm, consentono di effettuare lanci estremamente raccolti e millimetrici.

*Designed for the precision casting of considerable quantities of maggot balls and loose maggots. The exclusive pouch made of moulded rubber and the 5 mm elastics make it possible to cast with the most extraordinary precision.*

Code	Soft Pouch	Elastic ø mm	gr.
FNCQ04B	4	5,00	86,0

# HIGH QUALITY

## DEVILPULT STICKY MAGGOTS

Il cestello della Sticky Maggots è stato realizzato in poliestere, anziché in gomma: questo particolare, oltre ad un'apertura del cestello di ben 7 cm, permette il lancio di palle di pastura o di bigattini incollati, di dimensioni ancora più consistenti.

*The pouch of the Sticky Maggots is made of polyester rather than rubber: this feature, combined with a pouch aperture of no less than 7cm, makes it possible to cast groundbait balls or sticky maggots of even larger size.*

CODE	Elastic ø mm	gr.
FNCQ04C	5,00	97,0



**POLYESTER MESH POUCH**

## SPARE POUCH

CODE	Size	ø mm	Gr
FNCQ05	1	4,5	2,60
FNCQ05A	2	5,0	3,80
FNCQ05B	3	5,5	5,60
FNCQ05C	4	7,0	8,00

**NEW POUCH**

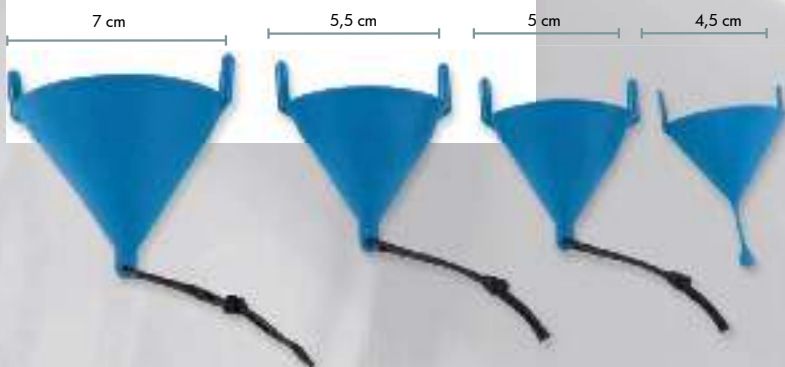

## POLYESTER MESH POUCH

CODE: FNCQ05D



## SPARE ELASTIC



CODE	Color	ø mm
FNCQ06	Yellow	3,00
FNCQ06A	VIOLET	4,00
FNCQ06B	BLACK	4,50
FNCQ06C1	RED	5,00
FNCQ06D	GREEN	6,00
FNCQ06E	BLACK	7,00

## RUBBER MESH POUCH

CODE	Color
FNCQ05E	BLACK
FNCQ05F	RED





**CHEYENNE**

**CODE: ST204**

Esteticamente perfetto. Lama in acciaio 440-A. Manico in frassino. Custodia in pelle. Ottimo per la caccia.

*Aesthetically perfect. Blade in 440-A steel. Ash wood handle. Leather case. Great for hunting.*

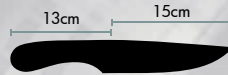

**APACHE**

**CODE: ST206**

Essenziale nella forma. Lama in acciaio 440-C. Manico in legno pregiato. Custodia in pelle con passa cintura. Ottimo per la Caccia.

*Essential shape. Blade in 440-C steel. Wood handle. Leather case with fitted lap belt. Great for hunting.*

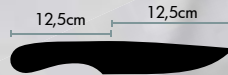

**CHEROKEE**

**CODE: ST207**

Lama in acciaio 440-C dotata di una inserzione per il taglio di cimi e sagole. Custodia rigida in trevira con passa cintura. Caccia e pesca.

*440-C steel blade fitted with an insertion for cutting tips and lines. Hard Case in "Trevira" with lap belt. Ideal for hunting and fishing.*

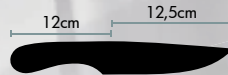

**NOIRE**

**CODE: ST208**

Lama in acciaio 440-C. Manico in legno pregiato. Custodia rigida in trevira con passa cintura. Caccia e pesca. **SOLD OUT**

*440-C black steel blade. Precious and elegant finishes. Weight: 145gr. A beautiful knife for an easy gift.*

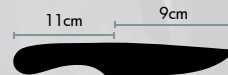

**STORM**

**CODE: ST209**

Lama in acciaio 440-C. Manico in legno pregiato. Custodia rigida in trevira con passa cintura. Caccia e pesca. **SOLD OUT**

*Blade in 440-C stainless steel. Fine finishes. Handle in walnut wood. Footprint. Weight 110gr. Minimum dimension. Safety device. Ideal for a gift.*







STAINLESS  
STEEL

## FINLAND

CODE: ST201

Lama da filetto, tagliente e flessibile. Inox 440-C. Manico in castagno leggerissimo. Fodero in pelle.

*Sharp and flexible blade for filleting fish. 440-C Steel. Light chestnut handle. Leather case.*

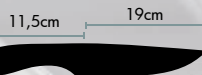

## SHERPA

CODE: ST105

Ottimo per sfilettare. Lama affilata e flessibile. Manico in elastomero a forma ergonomica. Costodia in plastica rigida con passa cintura. Adatto per la pesca in mare e acqua dolce.

*Excellent for filleting. Sharp and flexible blade. Ergonomic shape handle in Elastomer. Hard plastic case with lap belt. Suitable for fishing in sea and fresh water.*

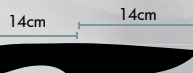

## FORBICI TRIPLE TRITON

TRITON TRIPLE SCISSORS

CODE: ST796

Ideata appositamente per il taglio dei vermi in tre parti, con un solo colpo.

*Specially designed to cut worms into three parts in one go.*



## FORBICI MINI

MINI SCISSORS

CODE: ST795

Classica forbice di piccole dimensioni con struttura in acciaio anti ossidante e micro dentatura perfetta per tagliare qualsiasi tipo di multi fibra o trecciato.

*Small sized scissors, such as the reinforced plasticated handle, able to perform also on heavy-duty cuts, the stainless steel frame and the micro tooth blade that is perfect for cutting any kind of braid line.*



## FORBICI RAPID

RABID SCISSORS

CODE: ST801

Piccole forbici di forma tradizionale con lame in acciaio inox, resistenti e durevoli. Il manico è dotato di particolare finitura gommata, utile ad una migliore impugnatura.

*Small scissors of traditional shape with strong and long-lasting blades in stainless steel. The handle has a special rubberised finish which makes for a better grip. Very light and sharp.*



## MANGUSTA

CODE: ST800

Piccole forbici con manico in plastica, pratiche ed essenziali. Le lame rientrano perfettamente nel manico, dopo l'uso.

*Essential and practical small scissors with plastic handle. The blades retract perfectly into the handle after use.*

11,5cm



## LUX

CODE: ST802

Questo pratico taglia nylon a pressione, leggerissimo ed affilato, è dotato di pomelli gommati per l'impugnatura e di ago per la tensione delle asole. Un accessorio molto utile ed estremamente economico.

*This very practical pressure nylon-cutter, very sharp and light, is equipped with rubber knobs for gripping and a needle for the tension of the loops. A very useful and extremely cheap accessory.*

6cm



## MOSQUITO

CODE: ST993

Forbice in acciaio a molla riesce a tagliare facilmente qualsiasi monofilo ma super indicata per i multifibra.

*Scissor in steel, very light, it can easily cut any monofilament. Suitable for multi-fiber.*



12,5cm



## PINZA SPLIT RING

SPLIT RING PLIERS

CODE: ~~ST994~~ **SOLD OUT B**

19cm



**NEW 2018**

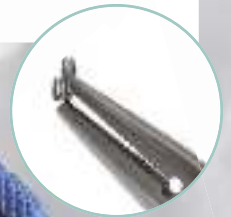

## PINZA RIVER

RIVER PLIERS

CODE: ST996

Pinza Colmic della migliore qualità. Realizzata in acciaio e carbonio (High Carbon Steel) con impugnatura gommata, becco liscio e zona di taglio. Ideale per slamare, stringere pallini di piombo, tagliare cavetti e monofili.

*High-quality pliers by Colmic. Made of steel and carbon (High Carbon Steel) with rubber grip, smooth peg and cutting part. Ideal for tightening the leads, disgorging, cutting cables and monofilaments.*

12cm



## PINZA ROXY

ROXY PLIERS

CODE: ST995

Pinza Colmic della migliore qualità. Realizzata in acciaio e carbonio (High Carbon Steel) con impugnatura gommata e becco liscio. Ideale per stringere pallini di piombo, schiacciare ardiglioni e slamare.

*High-quality pliers by Colmic. Made of steel and carbon (High Carbon Steel) with rubber grip and smooth peg. Ideal for tightening the leads, pressing the hook's barbs and disgorgering.*

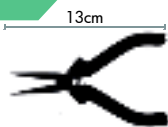

## CONDOR

ROXY PLIERS

CODE: ST991

La caratteristica principale di questa pinza, sono gli speciali perni ad espansione che ci permettono di aprire gli anelli degli ami per inserirci le girelle. Dotata di sistema stringi manicotti, la pinza CONDOR è fornita anche di due cesoie affilatissime.

*The main feature of these pliers is the special expansion pins that can be used to open the rings of the hooks to insert the swivels. Complete with a tube-tightening system and non-slip ergonomic handle, the CONDOR pliers is also provided with two extremely sharp shears.*



## CRIMP 210

CODE: ST992A

1° FORO/HOLE: 0,5MM - 1MM

2° FORO/HOLE: 1MM - 2MM

3° FORO/HOLE: 2,20MM



## CRUSH XT 300

CODE: ST99

18cm



## CRUSH XT 500

CODE: ST990A

18,5cm



STAINLESS  
STEEL

## MASTELLO

GROUND BAIT VAT

CODE	size
SEC01	25 lt
SEC02	40 lt

## SECCHI

BLUE GROUND BAIT BUCKET

CODE	size
SEC	17 lt
SEC03	12 lt

## COPERCHIO

YELLOW LID

CODE	size
SEC00	17 lt
SEC03A	12 lt

## SECCHIO LIVE FISH

LIVE FISH BUCKET

Questi secchi sono stati ideati per tutti i pescatori che vogliono mantenere le esche vive. A differenza di altri prodotti simili sul mercato, il LIVE FISH è dotato di un cestello estraibile e separabile dal secchio, in modo tale da toglierlo dall'acqua ed afferrare la nostra esca senza dover ricorrere a retini o come molte altre volte, immergervi la mano. La parte superiore del cestello è dotata di chiusura a scatto, ed è possibile applicarci un'ossigenatore.

*Unlike other similar products on the market, the LIVE FISH has a basket that can be separated and extracted from the bucket, so that the bait can be removed from the water without having to resort to nets or, as in many cases, having to use your hand. The upper part of the basket has a snap closure device, and it can also be fitted with an oxygenator.*

CODE	size
SEC05	7 lt
SEC06	12 lt

## BACINELLE

BASINS

CODE	dim. (cm)	Lt.
SEC10	ø 34 x h.12	5
SEC11	ø 40 x h.17	9
SEC11A	ø 43 x h.19	13

## BAIT VAPORIZER

CODE: VAP01A

Code	size
VAP01A	1 lt



## COPRISECCHIO ANTIPIOGGIA

### RAINPROOF BUCKET LID

Facile da applicare al secchio, tramite un elastico posto sul bordo e dotato di un foro decentrato per il rapido inserimento della mano, questo innovativo prodotto è sicuramente indispensabile per l'agonista, ma anche per l'amatore.

*With an elasticised edge so that it is easy to apply to the bucket, it also has an off-centre aperture so you can put your hand in quickly; this is definitely an indispensable article for competitor and amateur anglers alike.*

**SOLD OUT**



## VAGLI

### MESH RIDLE

Vagli indicati per setacciare pasture e terre realizzati in diverse misure di maglie per ogni tipologia di terre e farine e con due diversi diametri per esser alloggiati sia sul secchio, sia sul mastello. Consigliamo il vaglio con la maglia di diam. 2 per la setacciatura di terre, la maglia di diam. 3 per terre e pasture e le maglie di diam. 4-5 per pasture e tutti i tipi di sfarinati.

*Round riddles designed for sifting groundbait and leams, produced with different gauge mesh for all types of groundbait texture, and in two different diameters to fit on the bucket and the tub. We recommend the riddle with mesh of diameter 2 for sifting leams, the diameter 3 mesh for leams and groundbait mixes and the diameter 4-5 meshes for groundbaits and all types of mixes.*

#### 17cm X 17cm

CODE	dim. (cm)	Net (mm)
<b>SOLD OUT</b>	17x17	2

#### Ø 30cm

CODE	dim. (cm)	Net (mm)
VA20	Ø 36	4

#### Ø 36cm FOR BUKETS 12-17lt

CODE	dim. (cm)	Net (mm)
<b>SOLD OUT</b>	Ø 36	2
<b>SOLD OUT</b>	Ø 36	3
<b>SOLD OUT</b>	Ø 36	4
<b>SOLD OUT</b>	Ø 36	5

#### Ø 44cm FOR BUKETS 20-40lt

CODE	dim. (cm)	Net (mm)
<b>SOLD OUT</b>	Ø 44	3
<b>SOLD OUT</b>	Ø 44	4
<b>SOLD OUT</b>	Ø 44	5



## MIXER PER PASTURA

### GROUNDBAIT WHISK

Miscelatori di pastura a 6 e 8 fruste, prodotti in acciaio inox e dotati di asta a sezione circolare con superficie grippante anti rotolamento. Speciale profilo a tronco di piramide che consente una migliore aderenza alle pareti del secchio o del mastello e una più efficace miscelazione.

*Groundbait mixer with 6 and 8 blades, made in stainless steel and complete with roll-proof hexagonal-section stem to guarantee an effective grip on baskets' walls for a great mixture.*

CODE	Description
MIX309	6 fruste / 6 blades
MIX310	8 fruste / 8 blades



## MATRIOSKA - 2 BOXES

CODE: SC021



1,5Lt.

2Lt.



## MATRIOSKA - 5 BOXES

CODE: SC02

Kit ufficiale per la misurazione delle esche per le competizioni con regolamento CIPS. Composta da cinque contenitori da 1/8, 1/4, 1/2, 3/4, 1 litro.

Official kit for measuring the amount of bait during competitions under CIPS regulations. The kit includes five boxes of 1/8, 1/4, 1/2, 3/4, 1 litre.



## BOX VERDE VASE JOKER

CODE: SC02A

Contenitore di misura regolamentare porta ver de vase. Un lato contiene 50 gr di esche mentre l'altro lato, diviso in 2 scomparti da 25 gr ciascuno, è ideale per tenere separati diversi tipi di esche.

*This bloodworm box can contain up to 50gr bloodworms on one side, while the other side is divided in 2 compartments that can contain up to 25gr each. Ideal for keeping separate different kind of baits.*



## BAIT BOX TB SERIES

Set composto da tre scatole porta esche circolari, con coperchio.

Series of bait boxes with lid made of rubberised material.

**SOLD OUT**



## PORTA MAGIC BOX

CODE: SC03

SET = FRAME + 2 PZ MAGIC BOX 1,00LT

Tramite una vite di misura standard posizionata nel centro del piatto, è possibile collocarlo su di un paletto multiuso, oppure sul nostro panierino tramite un attacco a 90°.

*It can be attached to a multipurpose bankstick using a standard size screw set in the centre of the tray, or hooked onto the seatbox using a 90° clamp.*



## FUTURA BOX

Pratiche scatole in plastica realizzate in materiale infrangibile per piccoli accessori da pesca. Ciascun alloggiamento è protetto da un coperchio trasparente e le due parti di cui è composta la scatola sono ripiegabili l'una sull'altra con clip di chiusura.

*Handy, practical boxes made of unbreakable plastic for small fishing accessories. Each compartment has a transparent lid and the two halves of the box fold together and are secured by a clip.*

CODE	Color	Size
SCFU02	Orange	9,5x6,5
SCFU03	Dark green	9,5x6,5
SCFU05	Black	12x10



## MAGNETIX

Praticissima scatola magnetica porta ami, realizzata in materiale Anti Urto. *Ultra-practical magnetic hook box, made from shockproof material.*

CODE	Item	Size (mm)	Description
SC20	Magnetix 20	122x80x20	25 scomparti/compartiments
SC21	Magnetix 30	145x115x20	44 scomparti/compartiments

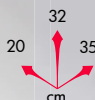

## ABS MULTI-USE BOX

CODE: BO118

Composta da un vano superiore chiuso ermeticamente, e completamente vuoto, dentro il quale è possibile riporre mulinelli, accessoristica varia ed altro ancora. La parte inferiore è caratterizzata da un ampio spazio chiuso da sportello, dove sono stati disposti tre contenitori in plastica trasparente. Questi contenitori scorrono dentro la cassettera in maniera eccellente, poiché delle guide stampate, poste internamente alla MULTI-USE, convogliano alla perfezione le scatole durante la loro corsa. Le scatole in plastica sono componibili internamente in vario modo, tramite delle lamelle amovibili, le quali possono suddividere l'oggetto a seconda delle proprie necessità. Dotata di maniglia in plastica e di tracolla, per un più comodo trasporto, la cassettera in ABS MULTI-USE è così robusta, da poter essere usata anche come sgabello!

*This Colmic case in ABS consists of a completely empty, hermetically-sealed upper compartment for holding reels and any other accessories. The lower section is in the form of a chest complete with door, inside which are three containers in transparent plastic. These containers slide in and out with ease on the special runners set into the structure of the MULTI-USE. The plastic boxes are modular inside, so that they can be organised to suit your needs using the removable dividers. Complete with plastic handle and shoulder strap for ease of transport, the MULTI-USE case in ABS is so strong that it can even double up as a stool!*



## POLE KEEPER

CODE: AP15

Realizzato con una speciale maglia a rete doppia, questo retino ferma RBS è dotato anche di un supporto in neoprene antiurto che evita rotture accidentali.

*Made from a special double-mesh net, this Roubaisienne stopper net is equipped with a support in shockproof neoprene to avoid accidental breakages.*



## POLE POT

CODE: COU03

Scodellini in plastica da posizionare sulla vetta della roubaisienne per una pasturazione di massima precisione.

*Plastic small bowls to use positioned on the tip of the long pole for the most accurate and precise baiting.*



200 ml

150 ml

Ø 4,25mm

75 ml

Ø 5,45mm

## NET POT

CODE: COU04

Set di scodellini realizzati in rete rinforzata da applicare al CUPPING KIT per una pasturazione di massima precisione.

*Set of pots in reinforced mesh to be applied to the Cupping Kit for maximum precision groundbaiting.*



Ø 10 cm

Ø 8 cm

Ø 4,25mm

Ø 5,25mm

## DOUBLE POT

CODE: COU05

La sua forma a doppia conicità consente di pasturare in quantità doppie rispetto ad una normale coppetta, nonché d'intervenire sulle pasture/terre scegliendo consistenze anche diverse e di usare abbinamenti di esche altrettanto variegati. Il DOUBLE POT è leggerissimo, con una capienza di 250ml ed ha in dotazione due connettori a vite (1 con diametro interno di 4,25 mm ed 1 con diametro interno di 5,45 mm) quindi adattabili a differenti conicità del cupping kit.

*Its special double shape permits you to feed the fish twice the amount than a normal cup, it also enables you to select your ground bait/soil by choosing different textures. It also permits you to feed a variety of bait combinations. The DOUBLE POT is very light with a 250 ml capacity and comes with two screw connectors (1 with internal diameter of 4,25 mm and 1 with internal diameter of 5,45 mm) therefore adaptable to the various cupping kit types.*



250ML



## JOINT CLEANER

Realizzati in neoprene, gli utilissimi JOINT CLEANER, contribuiscono al mantenimento della pulizia all'interno delle sezioni e rendono più efficace l'azione d'innesto tra le sezioni stesse. Questi accessori, sono quindi preventivi nei confronti dell'usura e dell'abrasione, ma aiutano anche ad evitare che il pezzo affondi sott'acqua, in caso di disinnesto fortuito.

*Made of neoprene, these extremely practical JOINT CLEANERS help you to keep the insides of the rod sections clean, while also enhancing the smoothness of assembly and take-apart procedures. As a result, these items offer a form of prevention against wear and abrasion while also ensuring that the piece does not sink into the water, as can happen if it unexpectedly comes apart.*

CODE	Ømm	Sect.
JOINT11	11	3°
JOINT21	21	4°
JOINT30	30	5°
JOINT34	34	6°
JOINT36	36	7°



## ELASTIC PROTECTOR

CODE: CCYPZ13

Questo dispositivo, è stato ideato per salvaguardare l'elastico della propria roubasienne, quando filler tip e seconda sezione, vengono ripiegati su se stessi.

*This accessory has been designed to protect the elastic of the Roubaisienne when the filler tip and second section are folded back on themselves.*

5pcs per Bag



## EXPANDA BUNG

CODE: CCYPZ12

Una vera protezione attiva per la vostra roubasienne. Realizzato in neoprene e silicone, è adattabile a qualsiasi diametro e modello di canna tramite un semplice dispositivo a vite che va ad uniformarsi con la sezione dell'attrezzo.

*A genuine protection for your Roubaisienne. Made in neoprene and silicone, it can be adapted to any diameter and model of rod using a simple screw mechanism so that it precisely matches the section of the rod.*





## POLE BUNG

### CODE: DIB7 (SMALL)

Adattabile alla seconda sezione Match e prima sezione Carpa (Filler-Tip).

*Designed for to the second section of Match and first section of Carp (Filler Tip).*

### CODE: DIB8 (MEDIUM)

Adattabile alla terza sezione Match e seconda sezione Carpa.

*For the third section of Match and second section of Carp.*

### CODE: DIB9 (LARGE)

Adattabile alla quarta sezione Match e terza sezione Carpa.

*Special for the fourth section of Match and third section of Carp.*

## SCALETTA ANTIURTO

SHOCKPROOF TENSIONER

CODE	Size	ø mm
DIB1	Small	9,5
DIB4	Xlarge	31

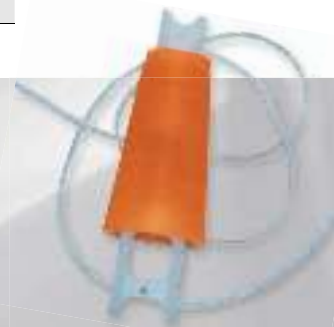

## TEFLON

20pcs per Bag

### OUTSIDE PTFE BUSH TIP CONNECTOR

CODE	Size	i.d.mm
TEFEXT25	25	2,50
TEFEXT27	27	2,70
TEFEXT30	30	3,00
TEFEXT32	32	3,20
TEFEXT35	35	3,50
TEFEXT40	40	4,00



20pcs per Bag

### INSIDE PTFE BUSH TIP CONNECTOR

CODE	Size	i.d.mm	O.D.mm
TEFINT20	20	1,50	2,00
TEFINT25	25	1,75	2,50
TEFINT28	28	2,00	2,80
TEFINT30	30	2,30	3,00
TEFINT35	35	2,60	3,50
TEFINT40	40	3,10	4,00
TEFINT43	43	3,30	4,30
TEFINT45	45	3,50	4,50
TEFINT48	48	3,80	4,80
TEFINT52	52	4,20	5,20

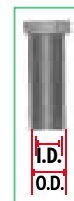

## DAMPER

### COLOR DAMPER 5MT

Elastico pieno in lattice di primissima qualità. I rigorosi test ai quali è stato sottoposto durante il processo di produzione, garantiscono un diametro costante, sinonimo di allungamento regolare e progressivo. L'innovativo processo di trattamento superficiale permette un perfetto ritorno nella vetta dopo il suo allungamento anche in caso di elastico bagnato.

*Hi-quality pure latex elastic. The elastic is subjected to meticulous tests during production that guarantee a constant diameter, a synonym of regular and progressive elongation. The innovative treatment coating process allows a perfect return into the tip after its elongation, even when the elastic is wet.*

CODE	Color	ø mm
ELDAM01	Orange	0,80
ELDAM02	Blue	0,90
ELDAM03	Violet	1,00
ELDAM04	Orange	1,20
ELDAM05	Pink	1,40
ELDAM06	Blue	1,60
ELDAM07	Green	1,80
ELDAM08	Red	2,10



### HOLLOW ELASTIC

L'Hollow elastic, rispetto ad un elastico tradizionale, ha una maggiore durata nel tempo, un superiore allungamento, una ritrazione assai più veloce, una versatilità superiore.

*Hollow elastic, compared to the traditional one, has a longer length in the time, a higher extension, a much faster retraction, a higher versatility.*

#### ELASTIC - 3,00 MT

CODE	Color	ø mm
ELT	Blue	1,20
ELT0	White	1,50
ELT00	Pink	1,80
ELT01	yellow	2,10
ELT01A	blue	2,30
ELT02	green	2,50
ELT03	orange	3,00
ELT04	red	3,50
ELT041	yellow	3,80

#### ELASTIC - 5,00 MT

CODE	Color	ø mm
ELT042	Blue	1,20
ELT04A	White	1,50
ELT05	Pink	1,80
ELT06	yellow	2,10
ELT07	blue	2,30
ELT08	green	2,50
ELT09	orange	3,00
ELT10	red	3,50
ELT11	yellow	3,80

## SILICON TUBE



### SILICON TUBE

Questi tubetti sono stati realizzati in puro silicone di prima qualità made in Italy. Ogni confezione contiene 20 tubicini da 5 cm ciascuno.

*These little tubes are made of top quality Made in Italy pure silicone. Each pack contains 20 5 cm tubes.*

20pcs per Bag  
21pcs per Pack

CODE	ø mm
GS103	0,30
GS105	0,50
GS107	0,70
GS110	1,00
GS120	1,20
GS150	1,50
GS200	2,00

### HIGH-TECH SILICON TUBES

La sua migliore caratteristica è quella di fare pochissimo spessore sulla deriva del galleggiante. Infatti ogni misura ha una parete di soli 0,3mm. Cartelle da 10 buste nelle quali ci sono 10 tubicini da 5 cm ciascuno.

*Its main feature is about the very thin wall, that makes a very small gap on the float stem. Every diameter has a wall of just 0,3 mm. It is sold in cards of 10 bags in which there are inside 10 tubes of 5 cm each length.*

10pcs per Bag  
10pcs per Pack

Code	Size	
SILHT01	0,30mm	Green - inside diam. 0,30mm, stems of 0,40-0,50-0,60mm
SILHT02	0,50mm	Red - inside diam. 0,50mm, stems of 0,60-0,70-0,80mm
SILHT03	0,70mm	Black - inside diam. 0,70mm, stems of 0,80-0,90-1,00mm



### SILICON BOX

Micro tubi in Silicone puro Made in Italy. Viene venduto in una comoda scatola con quattro scomparti in ognuno dei quali ci sono 20 tubicini da 5 cm l'uno, per un totale di 4,00 mt di silicone.

*Micro tubins of pure silicon Made in Italy. Sold in practical dispenser with four compartments in which there are 20 tubins of 5 m each compartment, for a total length of 4,00 mt of silicon.*

80pcs per Bag  
12pcs per Pack

CODE	mm
SICP1	0,30 / 0,50 / 0,70 / 1,00
SICP2	1,00 / 1,20 / 1,50 / 2,00



# HIGH QUALITY

## STICK RUBBER STOPPER

1 pcs per Bag  
10 pcs per Pack

CODE	Size	n° per bag	Nylon mm
GM 500402	2	1	0.23 - 0.47
GM 500404	4	1	0.14 - 0.33
GM 500408	8	1	0.10 - 0.23
GM 500410	10	1	0.08 - 0.16



## OLIVE RUBBER STOPPER

1 pcs per Bag  
10 pcs per Pack

CODE	Size	n° per bag	Nylon mm
GM 500302	2	1	0.23 - 0.47
GM 500304	4	1	0.14 - 0.33
GM 500308	8	1	0.10 - 0.23



## HOOK ANCHOR WINDER

CODE: TNTE

10 pcs per Bag  
10 pcs per Pack



## ANCHOR WINDER

CODE: TNCO

10 pcs per Bag  
10 pcs per Pack



## ULTRA LIGHT

2 pcs per Bag

CODE	Ø mm
ST04	3,00
ST05	4,50



## ULTRA LIGHT BULB

1 pcs per Bag

CODE	Ø mm
ST07	4,50



## TIP LIGHT

2 pcs per Bag

CODE	Ø mm	Ø TIP mm
ST09	4,50	2,7-3,2
ST10	5,00	3,3-3,7
ST101	6,00	3,8-4,3



## LUMINOUS OVAL BEADS

10pcs per Bag

CODE	n°	size
PE201	1	2x3
PE202	2	3x4
PE203	3	3,5x5
PE204	4	4x5
PE205	5	4x6
PE206	6	5x7
PE207	7	6x8
PE208	8	6x10



## LUMINOUS ROUND BEADS

10pcs per Bag

CODE	n°	size
PE303	3	3,00
PE304	4	4,00
PE305	5	5,00
PE306	6	6,00
PE307	7	7,00
PE308	8	8,00
PE310	10	10,00

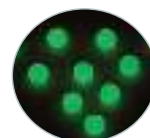

## OVAL BEAD

5pcs per Bag

WHITE CODE	YELLOW CODE	RED CODE	n°	size
PE10B	PE10G	PE10R	0	5x12
PE11B	PE11G	PE11R	1	5,8x14
PE12B	PE12G	PE12R	2	6,5x16
PE13B	PE13G	PE13R	3	7,5x18
PE14B	PE14G	PE14R	4	9x21
PE15B	PE15G	PE15R	5	10x24

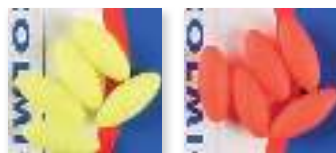

## FLOATING BEAD WITH STEM

5pcs per Bag

WHITE CODE	YELLOW CODE	RED CODE	n°	size
PE45B	PE45G	PE45R	5	5,00
PE46B	PE46G	PE46R	6	6,00
PE48B	PE48G	PE48R	8	8,00



## ADESIVO STORMSURE

GLUE STORMSURE

**CODE: ADSS01**

 1pcs per Bag  
 12pcs per Pack

Collante adatto a molteplici usi. Ripara in maniera permanente stivali, tessuti rivestiti, neoprene, gomma, pelle, pvc, e tessuti plastici in genere. Flessibile ed impermeabile.

*Thousand of use. Permanent, flexible and waterproof repairs to coated fabrics, Neoprene, Rubber, Leather, PVC, PU, most Plastics and Fabrics.*



## LINE MARKER



Utilissimo pennarello segna filo, utilissimo per marcare il nylon sul mulinello.

*Very useful felt-pen for marking the line on the reel.*

 1pcs per Bag  
 12pcs per Pack

CODE	Size
PEN01	white
PEN02	yellow

# HIGH QUALITY



## ANTENNA MARK

Vernice fluorescente molto utile per colorare le antenne dei galleggianti.

*Retouching fluorescent varnish to paint the antennas of the floats.*

1 pcs per Bag  
6 pcs per Pack

CODE	Color
VEFL13	yellow
VEFL14	red
VEFL15	black



## BABY LIGHT



Le baby light si attivano automaticamente al contatto con l'acqua. Sono visibili fino ad una profondità di 20 metri e resistenti alla pressione dell'acqua fino a 300 metri.

*The baby lights are activated automatically on contact with the water. They are visible up to a depth of 20 metres and resistant to water pressure up to 300 metres.*

### DOUBLE FLASH

1 pcs per Bag  
10 pcs per Pack

CODE	color
LIGHT01	White
LIGHT02	Red



### SINGLE FLASH

1 pcs per Bag  
10 pcs per Pack

CODE	color
LIGHT03	White
LIGHT04	Blue
LIGHT05	Green
LIGHT06	Red



## CAMPANELLI

### BELLS

2 pcs per Bag  
10 pcs per Pack

CODE	item
BELL01	Double bell
BELL02	Single bell
<b>SOLD OUT</b>	Starlite bell

DOUBLE BELL



SINGLE BELL



STARLITE BELL



## BITE ALARM

CODE: BITE01

Avisatore di abboccata da applicare tramite una clip antigraffio sulle nostre canne. Dotato di un segnale acustico, è possibile anche tramite la luce a led vedere la tocca del pesce. Ideale per il Catfishing, Carp fishing, Surfcasting e tutte quelle tecniche di pesca a fondo, sia in acque dolci che in mare. Batterie incluse.

*Bite alarm that can be attached to the rod using a scratchproof clip. It has an acoustic signal, while the led light means that you can also visually detect the fish's bite. Ideal for Catfishing, Carp fishing, Surfcasting and all other deep fishing techniques, both in freshwater and in the sea. Batteries included.*

1 pcs per Bag  
5 pcs per Pack



## SALVANELLI "TOP ONE"

CODE: SALV10 (SMALL)  
CODE: SALV11 (LARGE)

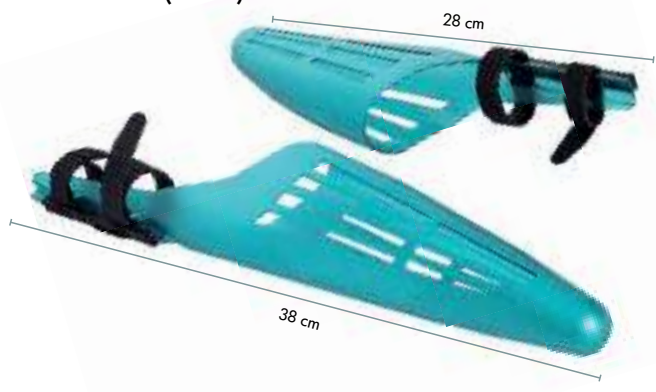

## SALVANELLI EASY

CODE: SALV12 (SMALL)  
CODE: SALV13 (MEDIUM)

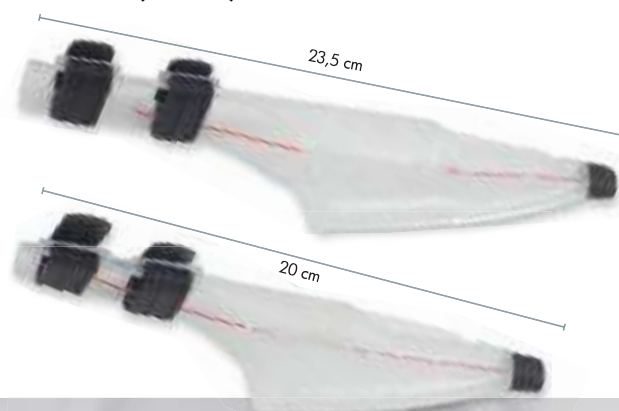

## ASTUCCIO PORTAFINALI

HOOKLENGHT RETAINING BOX

CODE	H.mm	Description
LIP010	25	Finali da 15cm, 20cm, 24cm
LIP011	35	Finali da 22cm, 26cm, 30cm, 33cm, 37cm
LIP012	50	Finali da 29cm, 35cm, 40cm, 45cm, 50cm



## TUBE

CODE: TUB00

CODE: TUB02

CODE: TUB03

CODE	Ømm	H.cm	Description
TUB00	52	192	prism Tube Roubaissienne
TUB02	52	182	prism Tube Top Kits
TUB03	-	182	Oval Tube Top Kits
TUB04	62	45	prism Float Holder

CODE: TUB04



Tubo porta galleggianti prodotto in PVC cm 45.  
Clear plastic float tube cm 45.



## BILANCE DIGITALI

### DIGITAL SCALE

Per tutti i tre modelli le caratteristiche tecniche sono le seguenti:

Misurazione del peso: chilogrammo, libbra ed oncia.

Rilevatore della temperatura esterna.

Funzione HOLD automatica.

Sul lato della bilancia è stato collocato un metro estraibile della misura di 1mt.

Batterie incluse nella confezione.

*For all the three models, the main and common technical features are:*

*Weight measure: Kilograms, Pounds and Ounces.*

*External temperature indication.*

*HOLD automatic function.*

*On the right side of the scale there is an extractable ruler long 1,00 mt.*

*Battery included.*

CODE	Max weight	Sensibility
BILD1501	15 Kg	1,00gr
BILD2505	25 Kg	5,00gr
BILD4010	40 Kg	10,00gr



## SLAMATORE EURO

1 pcs per Bag  
10 pcs per Pack

CODE	Size
SLA01	small
SLA02	medium
SLA03	large



## SLAMATORE PIN STANDARD

1 pcs per Bag  
10 pcs per Pack

CODE	Size
SLA04	standard
SLA05	small

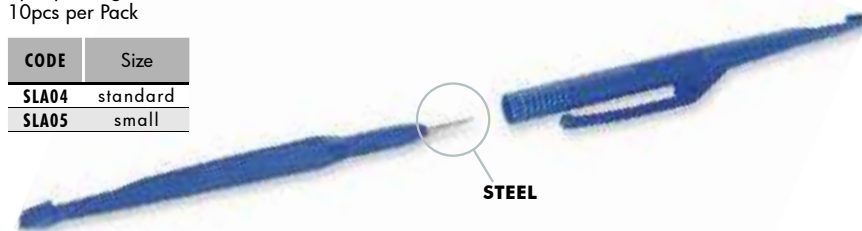

## ESPOSITORE PIOMBI

LEAD DISPENSER

CODE: ESPCOE

# LEAD

La COLMIC, sempre all'avanguardia nella ricerca sulle materie prime, ha fatto un importante investimento sullo sviluppo di una qualità di piombo superiore MADE IN ITALY. Questo si è tradotto in un miglioramento molto importante nella qualità dei pallini di piombo spaccato. Oltre a risultare perfettamente calibrati, i pallini di piombo spaccato si stringono infatti facilmente sul filo senza intaccarlo, mantenendo le stesse proprietà anche in fase di posizionamento dei pallini sul nylon per ogni esigenza di pesca.

*COLMIC, always in the vanguard for research into raw materials, has made significant investments in the development of a superior quality of MADE IN ITALY lead. In practice, this has resulted in a very important improvement in the quality of the split shots. In addition to being perfectly calibrated, the split lead shots grip the line perfectly without damaging it, also maintaining these properties in the phase of positioning of the shots on the nylon for all fishing requirements.*

### CONVERSION TABLE

CODE	gr.	CODE	gr.
14	0,010	3	0,194
13	0,013	2	0,242
12	0,019	1	0,288
11	0,028	0	0,347
10	0,040	1/0	0,370
9	0,060	2/0	0,394
8	0,070	3/0	0,475
7	0,095	4/0	0,532
6	0,102	5/0	0,705
5	0,132	6/0	1,057
4	0,162	8/0	1,878



MADE IN ITALY

37,5  
24 25,5  
cm

# SUPER SOFT CALIBRATED LEAD

## BOX 30GR

CODE	size	CODE	size
POBB114	14	POBB103	3
POBB113	13	POBB102	2
POBB112	12	POBB101	1
POBB111	11	POBB100	0
POBB110	10	POBB011	1/0
POBB109	9	POBB010	2/0
POBB108	8	POBB009	3/0
POBB107	7	POBB008	4/0
POBB106	6	POBB007	5/0
POBB105	5	POBB006	6/0
POBB104	4		



## BOX 100GR

CODE	gr.
POZB15	0,50
POZB16	0,70
POZB17	1,00
POZB18	1,50
POZB19	2,00
POZB20	2,50
POZB21	3,00
POZB22	4,00



# HIGH QUALITY

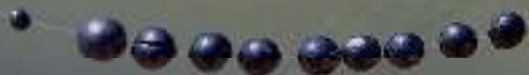

## GIGANTE

11 COMPARTMENTS - 350GR

Code	Sizes
POMAF1	11 - 10 - 9 - 8 - 7 - 6 - 5 - 4 - 3 - 2 - 1

# MASCOTTE TICINO

## FINE

5 COMPARTMENTS - 120GR

CODE	Sizes
POZF10	10 - 8 - 6 - 4 - 2



## MEDIA

5 COMPARTMENTS - 120GR

CODE	Sizes
POZF20	7 - 5 - 3 - 1 - 1/0



# MASCOTTE SILE

## EXTRA FINE

7 COMPARTMENTS - 200GR

CODE	Sizes
POZF25	14 - 13 - 12 - 11 - 10 - 9 - 8



## FINE

8 COMPARTMENTS - 200GR

CODE	Sizes
POZF30	10 - 8 - 6 - 5 - 4 - 2 - 1 - 1/0



## GROSSA

8 COMPARTMENTS - 200GR

CODE	Sizes
POZF50	7 - 5 - 3 - 2 - 2/0 - 4/0 - 6/0 - 8/0



## ROUND MASCOTTE

### 6 COMPARTMENTS

Queste serie di Mascotte sono state ideate per ogni tipo di esigenza e di pesca di ogni singolo pescatore. Dal taglio perfettamente centrato, non intacca minimamente il nylon anche durante lo spostamento.

*This series of dispensers has been designed to satisfy all fishing needs and the demands of every angler. With a perfectly centred groove, they cannot minimally snag the nylon even during movement.*

CODE		sizes
POMAP1	Inglese	SSG - SG - AAA - BB - 1 - 2
POMAP2	Trota	6/0 - 4/0 - 3/0 - 1 - 2
POMAP3	Mare	8/0 - 7/0 - 5/0 - 2/0 - 0 - 2
POMAP4	Grossa	2/0 - 0 - 1 - 2 - 3 - 4
POMAP5	Media	3 - 4 - 5 - 6 - 7 - 8
POMAP6	Fine	7 - 8 - 9 - 10 - 11 - 12



## SQUARED MASCOTTE

### 7 COMPARTMENTS

CODE	sizes
POMAQ	2 - 4 - 6 - 8 - 9 - 10 - 11



## ROUND MASCOTTE

### 5 COMPARTMENTS

CODE	sizes
POMAG	0 - 2 - 4 - 6 - 8



## ROUND MASCOTTE

### 5 COMPARTMENTS

CODE	sizes
POMAP	3 - 5 - 7 - 9 - 11



Pallini di piombo selezionato dal taglio perfettamente centrato. Di media durezza, non intaccano minimamente il nylon, anche se fatti scorrere.  
*Selected lead shot with perfectly centred bore. Medium hard, they cannot minimally snag the nylon even when run down the line.*



## SPORT MASTER



CODE	sizes	CODE	sizes
SOLD OUT	6/0	POBB303	3
SOLD OUT	5/0	POBB304	4
SOLD OUT	4/0	POBB305	5
SOLD OUT	3/0	POBB306	6
SOLD OUT	2/0	POBB307	7
POBB211	1/0	POBB308	8
POBB300	0	POBB309	9
POBB301	1	POBB310	10
POBB302	2		

## SONDE NEOPRENE

NEOPRENE PROBE

2pcs per Bag

CODE	sizes
SON10	10
SON15	15
SON20	20
SON30	30
SON50	50



## SFERE CALIBRATE

CALIBRATED LEAD

Prodotte in piombo con microforo e misura stampata, sono ideali per la costruzione di lenze per la pesca con l'inglese scorrevole e per la realizzazione di lenze con galleggianti "vela".

Calibrated balls. Lead ball with micro hole and size printed on them for easy identification. Ideal for the construction of rigs with sliding wagglers and for fishing on running waters.

5pcs per Bag

CODE	gr.	CODE	gr.
POSFE01	0,50	POSFE06	6,00
POSFE01A	0,80	POSFE08	8,00
POSFE01B	1,00	POSFE10	10,00
POSFE01C	1,50	POSFE12	12,00
POSFE02	2,00	POSFE15	15,00
POSFE02A	2,50	POSFE20	20,00
POSFE03	3,00	POSFE25	25,00
POSFE04	4,00	POSFE30	30,00
POSFE05	5,00		



## TORPILLE JAZ



5pcs per Bag

CODE	sizes	CODE	sizes	CODE	sizes
TOJ0020	0,20	TOJ0150	1,50	TOJ0450	4,50
TOJ0030	0,30	TOJ0175	1,75	TOJ0500	5,00
TOJ0040	0,40	TOJ0200	2,00	TOJ0600	6,00
TOJ0050	0,50	TOJ0225	2,25	TOJ0800	8,00
TOJ0060	0,60	TOJ0250	2,50	TOJ0900	9,00
TOJ0080	0,80	TOJ0300	3,00	TOJ1000	10,00
TOJ0100	1,00	TOJ0350	3,50	TOJ1200	12,00
TOJ0125	1,25	TOJ0400	4,00		

## TORPILLE SUPREME



5pcs per Bag

CODE	sizes	CODE	sizes	CODE	sizes
TOS0020	0,20	TOS0175	1,75	TOS0800	8,00
TOS0040	0,40	TOS0200	2,00	TOS1000	10,00
TOS0060	0,60	TOS0250	2,50	TOS1200	12,00
TOS0080	0,80	TOS0300	3,00	TOS1400	14,00
TOS0100	1,00	TOS0400	4,00	TOS1600	16,00
TOS0125	1,25	TOS0500	5,00		
TOS0150	1,50	TOS0600	6,00		

## DIAMOND DROPS

### SHORT DIAMOND BOX D

#### 11 COMPARTMENTS

Serie di mascotte in piombo con tubetto interno in silicone per facilitare lo scorrimento ed impedire l'usura del nylon. Queste mascotte vengono proposte sia come classica torpilla "LONG" e sia come torpilla "SHORT" in varie grammature a seconda della mascotte scelta.

*Series of dispensers containing lead sinkers with a small silicone tube inside to prevent wear on the nylon. The dispensers contain both the classic "LONG" olivette shape and the "SHORT" olivette shape, in various different weights depending on the dispenser chosen.*



CODE	sizes
POMA01D	0,50 - 0,75 - 1,00 - 1,25 - 1,50 - 2,00 - 2,50 3,00 - 4,00 - 5,00 - 6,00

### SHORT DIAMOND BOX A

#### 7 COMPARTMENTS

Code	sizes
POMA01A	0,50 - 0,75 - 1,00 - 1,25 1,50 - 2,00 - 2,50



### SHORT DIAMOND BOX B

#### 7 COMPARTMENTS

Code	sizes
POMA01B	1,00 - 1,25 - 1,50 - 2,00 2,50 - 3,00 - 4,00



### SHORT DIAMOND BOX C

#### 7 COMPARTMENTS

Code	sizes
POMA01C	2,00 - 2,50 - 3,00 - 4,00 5,00 - 6,00 - 8,00



### LONG DIAMOND BOX A

#### 7 COMPARTMENTS

CODE	sizes
POMA02A	0,80 - 1,00 - 1,50 - 2,00 2,50 - 3,00 - 3,50



### LONG DIAMOND BOX B

#### 7 COMPARTMENTS

CODE	sizes
POMA02B	1,00 - 1,50 - 2,00 3,00 - 3,50 - 4,00 - 5,00



### LONG DIAMOND BOX C

#### 7 COMPARTMENTS

CODE	sizes
POMA02C	2,00 - 2,50 - 3,00 4,00 - 5,00 - 6,00 - 8,00



# COSMOTROUT

## LINES

### VETRINI SLIM

Vetrino da ricerca per la pesca alle trote in laghetto. Questa zavorra in vetro ci permette di "ricercare" le trote quando queste stazionano a mezz'acqua e risultano svogliate nell'attaccare la nostra esca. Grazie al suo peso specifico che una volta in acqua, si dimezza di circa la metà di un classico piombo, il vetrino ci permette di raggiungere la solita distanza di lancio del classico piombo di pari peso, ma con la possibilità di recuperi più lenti.

Search fishing glass sinker for still water trout fishing. This glass sinker will allow to "search" fish for suspended and aphatic trout. Thanks to the lighter glass specific weight, around half the lead weight, this glass sinker will allow us to reach the same casting distance but will also allow much slower retrieves.

20pcs per Bag

CODE	gr.
VETR12	2,00
VETR13	3,00
VETR14	4,00
VETR15	5,00



### VETRINI SHORT

Questo vetrino per la pesca alle trote in laghetto si differenzia dallo "Slim" per il corpo più corto e compatto. Anche questo tipo di zavorra è indicata nella pesca di velocità in laghetto a tremarella, ma anche per la pesca con il galleggiante, il quale grazie al suo minor peso specifico una volta in acqua rispetto ad un classico piombo, ci permette di fare il classico "striscio" per la ricerca di trote che stazionano a mezz'acqua.

*The mail difference between this still water trout fishing "Vetrino" sinker and the "Slim" one is the shorter and more compact body. Also this particular sinker is suitable for speed fishing and "Tremarella" style, but it's also perfect float fishing thanks to its lighter specific weight compared to a lead sinker, this will allow a mid dept search fishing action for suspended trout.*

20pcs per Bag

CODE	gr.	CODE	gr.
VETRO2	2,00	VETRO6	6,00
VETRO3	3,00	VETRO8	8,00
VETRO4	4,00	VETRO10	10,00
VETRO5	5,00		

### PIOMBO TROTA SHORT

Piombo per la pesca trota lago su trote attive ed aggressive. Grazie alla sua forma "corta" e' molto rapido nei saliscendi anche con le "tremarelle" più frenetiche, stimolando il pesce ad attaccare la nostra esca.

*Still water trout fishing expressly made for aggressive and active trout fishing. Thanks to its "short" shape it's fast in the up and down even with the most frantic "tremarella" action, stimulating the trout attack.*

5pcs per Bag  
10pcs per Pack

CODE	gr.
POTR0330	3,00
POTR0335	3,50
POTR0340	4,00
POTR0350	5,00
POTR0360	6,00



### PIOMBO TROTA SLIM

Piombino per la pesca di ricerca in trota lago che rispetto allo "short" distribuisce il suo peso su una maggiore superficie. Grazie a questa particolarità, si presta egregiamente nella ricerca di trote poco aggressive che stazionano a mezz'acqua.

*Search fishing trout lead, the difference between this lead and the "short" one is this lead distributes the weight on a longer surface. Thanks to this specific feature it's perfect to search fish for not very aggressive trout at middle level water down the water column.*

5pcs per Bag  
10pcs per Pack

CODE	gr.
POTR0220	2,00
POTR0225	2,50
POTR0230	3,00
POTR0235	3,50
POTR0240	4,00
POTR0250	5,00
POTR0260	6,00



### PIOMBO TROTA MICRO SLIM

Il piombo trota micro slim e' l'ideale per la pesca di ricerca in superficie a basse velocità di recupero. Ideale anche per la "tremarella" più delicata con trote apatiche e svogliate nell'attaccare la nostra esca.

*The trout fishing micro slim lead is perfect for search fishing close to the surface at slow retrieve. Perfect also for the more delicate "tremarella" fishing on aphatic and lazy trout.*

5pcs per Bag  
10pcs per Pack

CODE	gr.
POTR0430	0,30
POTR0450	0,50
POTR0470	0,70
POTR0499	1,00



## FLORIDA

CODE: CINT11

Cintura dal design curato Florida si evidenzia per la grande leggerezza e per la sua forma avvolgente che permette all'angler il massimo confort anche nei combattimenti più impegnativi.

*A carefully-designed fighting belt, the Florida is notable for its extreme lightness and its enveloping shape that give the angler the utmost comfort even during the most taxing battles.*



## MALDIVE

CODE: CINT12

Maldive è una cintura da combattimento estremamente versatile semplice e soprattutto leggerissima. Si adatta a qualsiasi angler adulto o bambino ed è la cintura ideale per una donna in quanto risulta più stretta della sorella maggiore Florida. Costruita in nylon e cordura permette al pescatore un confort ineguagliabile anche nei combattimenti più lunghi.

*The Maldive is an extremely versatile, simple and above all ultra-light fighting belt. It can fit any adult or child angler, and is perfect for women since it is slimmer-fitting than the big brother model Florida. Made of nylon and Cordura it offers the fisherman an unrivalled comfort even in the very longest battles.*



## MADAGASCAR

CODE: CINT10

Cintura da combattimento semplice leggera e di poco ingombro il modello Madagascar con il suo interno morbido e confortevole può essere indossata anche continuamente nell'azione di pesca soprattutto nelle tecniche del bolentino pesante e della traina con il piombo guardiano. Dotata di bicchierino basculante è adattabile a qualsiasi canna dotata di crociera ed è adattabile con la sua cintura regolabile a qualsiasi taglia di pescatore.

*A simple, light and streamlined fighting belt, the Madagascar model is so soft and comfortable inside that it can be worn throughout the fishing action, especially using heavy bottom fishing and trolling with sinker techniques. Complete with swinging gimbal pocket that can be adapted to any rod equipped with crosspiece, it also has an adjustable belt strap to fit any size of fisherman.*



## BUTTON FAST BLOCK + PVC BASE

CODE: BOAT08

Variante del BUTTON, che prevede la collocazione di fabbrica della base FAST BLOCK, su ulteriore superficie piana in PVC. Questo sistema consente di consolidare la base in questione su gommoni e canotti tramite collanti specifici e bi-componenti.

*This is a variant of the BUTTON in which the FAST BLOCK base is placed on another flat surface in PVC. This means that the base can be firmly attached even to dinghies using special bi-component adhesives.*



## SELF - 30°

CODE: BOAT12

Bellissimo e robustissimo portacanne in alluminio anodizzato, da fissare al bordo imbarcazione tramite viteria specifica. L'inclinazione di 30°, gli permette di essere collocato sui bordi laterali obliqui.

*Good-looking and really tough rod holders in anodised aluminium, to be fixed to the edge of the boat using specific screws. The angle of 30° that is perfect for being used on sloping lateral edges.*





# HIGH QUALITY

## DOUBLE

Questo portacanne da barca può essere fissato alle tubazioni del t-top di qualsiasi imbarcazione ed ha la caratteristica di adattarsi sia in orizzontale che in verticale tramite un robusto meccanismo a vite.

*This boat rod holder can be fixed to the bars of the t-top of any boat, and has a robust screw mechanism so that it can be adapted to both horizontal and vertical mounting.*

**SOLD OUT**

Ø 32mm

**SOLD OUT**



## U-BOOT

Questo robustissimo porta canne va collocato sulle tubazioni del t-top dell'imbarcazione. Il portacanne può essere posizionato in verticale o in orizzontale, a seconda delle proprie esigenze, ed è dotato di un particolare sistema a cremagliera, con molla di bloccaggio/sbloccaggio, il quale garantisce una perfetta rotazione del portacanne di 360°.

*This very tough rod-holder is designed to be attached to the bars of the t-top of the boat. It can be positioned vertically or horizontally, as required, and is equipped with a special rack system, with a lock/ release spring that guarantees the rod holder a perfect 360° rotation.*

**SOLD OUT**

Ø 25mm  
Ø 32mm

**SOLD OUT**



## NAKED

Pratici rod holder per l'alloggio delle canne a riposo, da fissare al telaio del t-top. Due versioni, una con finitura cromata e l'altra finitura ottone e due differenti diametri di base, per la collocazione su tubi di vario spessore.

*Practical rod holder for housing rods while not in use, to be attached to the frame of the t-top. Two versions, one with a chrome finish and the other with a brass finish, and two different base diameters to be attached to bars of different sizes.*

VERTICALE

HORIZONTALE

**SOLD OUT**

**SOLD OUT**

**SOLD OUT**

Ø 32mm

Ø 25mm  
Ø 32mm

**SOLD OUT**



## NEMO VERTICAL

CODE: NEMO V

Robusto portacanne per fissare sui bordi della barca, tramite viteria speciale, un grado di contenere tre canne a riposo durante la fase di spostamento.

*Vertical rod holder, to be attached to the sides of the boat using special screws, can hold up to three rods not being used, during the sailing stages.*

**SOLD OUT**



Alluminio anodizzato anticorrosione con raffinata "Silver". Basi in ABS rinforzato e viti in acciaio 304.

*Anodised rustproof aluminium with "Silver" refinement. Bases in strengthened ABS and screws in 304 steel.*



## EVA SPOOL BOX

CODE: EVA07

Scatola in plastica contenente 36 bobine Ø 4cm - H. 1,2cm.  
 Plastic box with 36 spools Ø 4 cm - H 1,2cm.

36pcs per Bag



## EVA SPOOL

Bobina in neoprene con incavo  
 Neoprene bobins with bowl

20pcs per Bag

CODE	Ø cm	H. cm	qt. pack
EVA01	4,00	1,20	20
EVA02	5,00	1,50	20
EVA03	6,00	1,50	20
EVA04	7,00	1,80	20
EVA05	9,00	1,80	20



## EVA SQUARED BAR

CODE: EVA10 (Green 12X11Xh.1,5cm)

CODE: EVA11 (Red 15X11Xh.2cm)

Tavoletta in neoprene con dentatura  
 Neoprene toothed Tablet

36pcs per Bag



## EVA FLAT BAR

CODE: EVA08 (GREEN 15X8,5XH.1,5CM)

CODE: EVA09 (RED 19X13XH.2CM)

Tavoletta in neoprene  
 Neoprene Tablet

10pcs per Bag



## WIRE LEADER BOX

Cavetto in acciaio coated (rivestimento plastico termosaldante) è confezionato in bobine da 10 mt ed ha in dotazione i manicotti (tubes) per il consolidamento finale.

*This coated steel cable (coated in heatsealed plastic) is packaged in 10 m reels and comes complete with the tubes to be tightened on the ends.*

CODE	Length	lbs.
NYWIRE08	10mt	15
NYWIRE09	10mt	22
NYWIRE10	10mt	33
NYWIRE11	10mt	45



## WIRE LEADER CARD

I presenti cavetti, disponibili in vari libbraggi e due differenti lunghezze, vengono proposti con un interessante confezione "card" da 50 pezzi (suddivisa in due scomparti da 25 pezzi cadauna).

Available in different weights and two lengths, the cables are proposed in an interesting packaging in the form of card holding 50 items (divided into two sections with 25 each).



50pcs per Bag  
10pcs per Pack

CODE	Length	lbs.
NYWIRE01	30cm	22
NYWIRE02	30cm	33
NYWIRE03	30cm	45
NYWIRE04	23cm	15
NYWIRE05	23cm	22

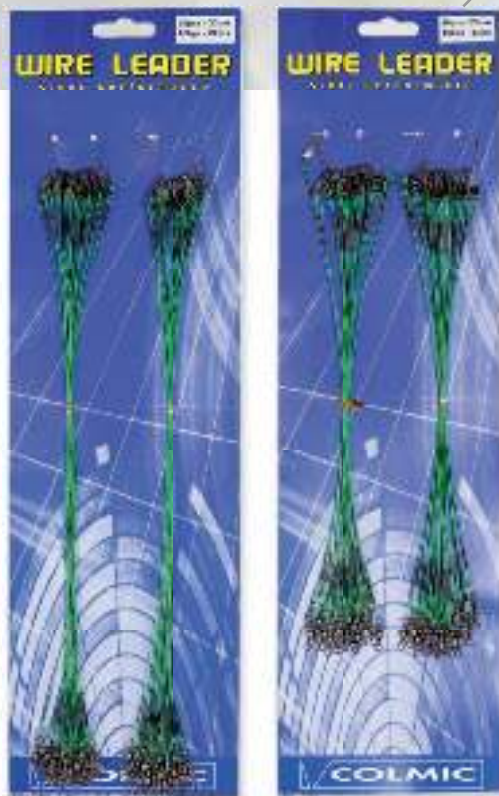

## COCO

CODE: COCO

Speciale Dyneema 100/100 trattato con additivi di copertura affinché la legatura abbia la massima resistenza all'abrasione. BRAIDED CONNECTION 0.10 mm deve essere usato sulla bobina di alluminio, ideale per congiungere Braided da 40lbs a 80 lbs con nylon fino ad un massimo di 100 lbs. BRAIDED CONNECTION 0.10 mm deve essere usato sulla bobina di acciaio, ideale per congiungere Braided da 40lbs a 80 lbs con nylon fino ad un massimo di 100 lbs. Includi nella confezione 2 bobine di BRAIDED COCO.

*Special Dyneema 100/100 treated with cover additive to obtain a tying with maximum resistance to abrasion. BRAIDED CONNECTION 0.10 mm must be used on aluminium spool, ideal to connect Braided from 40lbs to 80 lbs with nylon up to a maximum of 100 lbs. BRAIDED CONNECTION 0.10 mm must be used on steel spool, ideal to connect Braided from 40 lbs to 80 lbs with nylon up to a maximum of 100lbs.*



## BAIT ELASTIC

Filo elastico che permette di fissare le esche in modo pratico ed efficace. Il rocchetto gira agevolmente nell'astuccio in plastica nel quale è contenuto, favorendo così una rapida legatura. Infatti, il filo elastico esce dalla sua confezione tramite un piccolo foro e pertanto anche l'integrità non viene mai meno. Questo kit (astuccio + filo) garantisce un netto risparmio di filo, poiché potrete usarne fino all'ultimo centimetro. Inoltre, il rocchetto resterà sempre pulito e pronto all'uso.

*Bait Elastic that allows an easier, and yet efficient, wrapping of the bait. The spool turns easily inside its case so making possible a really quick wrapping. The packaging too has been studied in order to guarantee the safety of the Elastic, in fact the elastic gets out of the pack from a small hole, reducing the possibility of damages. This Kit (Elastic + Case) will allow you to save as much elastic as possible and to keep the spool always clean and ready to use.*

CODE	Ømm	mt
ELA01A	0,10	200
ELA01B	0,15	200
ELA01C	0,20	200
ELA01D	0,25	100



## ASCIUGAMANO 50X60

TOWEL 50X60

CODE: ASHB4060

Comodo e pratico asciugamano in cotone ideale per l'agonismo e per la pesca in generale, sia da riva che dalla barca.

*Handy and practical cotton towel, perfect for competitions and fishing in general, from either the shore or the boat.*



## ROD BAND OXFORD

CODE: RB28430X

L. 28,5CM X H. 4,3CM



## ROD BAND EVA

CODE: RB4070

L. 40CM X H. 7CM



## ROD BAND EVA

CODE: RB2220

L. 22cm X H. 2cm



## ASCIUGAMANO DA CINTURA

BELT TOWEL

CODE: ASHB244

Pratico e comodo asciugamano dotato di moschettone che consente l'aggancio alla cintura o al passante dei pantaloni. Ideale per ogni situazione di pesca, sia in acque dolci che in mare.

*Handy, practical towel complete with spring clip so that you can hang it from your belt or trouser belt-loop. Ideal for all freshwater and sea fishing situations.*



## SALVA DITO DA LANCIO IN NEOPRENE

FINGER GUARD

CODE: SALV01

Salvadito da lancio in neoprene realizzato per la pesca a surf casting e per il carp fishing.

*Neoprene finger guard when surf casting or carp fishing.*



## DISPLAY COCO

CODE: ESPCO



## ROD DISPLAY COLMIC RBS

CODE: ESP02



## ROD DISPLAY COLMIC CANNE

CODE: ESP01



## ROD DISPLAY

CODE: ESPCA



## BANDIERA A GOCCIA

FLAG

CODE: ZZZ01A

50cmx250cm



## BANNER COLMIC 4,00x1,00mt

CODE: ZZZ02





## KARPER

**CODE: PCBEL03A - 1kg**

Pastura a grana medio grossa, di colore ambrato, odore e sapore molto dolce, ha un ottimo potere legante e grazie alla sua tenacità può essere arricchita di esche vive oppure mais e canapa. In questa pastura è stato aggiunto il super concentrato "TOP SECRET" della champion feed, che possiede un potere attirante eccezionale per la pesca delle grosse carpe.

*Medium - large grained ground bait, amber-colored, sweet smell, with a great bending power. It can be mixed with live baits, boiled corn or hemp. We added to this already superb ground bait our "TOP SECRET" ingredient same as Champion Feed, which gives it an impressive attracting power, especially for the big carps.*



## MB 300 CARPA CARASSIO BREME

**CODE: PCBEL03B - 1kg**

Pastura a grana medio fine, di colore ambrato chiaro, leggermente legante, è ideale per la pesca di breme e carassi di media taglia in lago, in canali con acqua ferma oppure in acque con poca corrente. Per aumentare il potere attrattivo in estate, aggiungere il 10% di aroma touche, mentre in inverno il 10% - 15% di brasem.

*Medium-fine grained ground bait, light amber color, slightly bending, it's the perfect ground bait for fishing bream at lake, canals both in still and moderately running water. In order to increase its attracting power you can add a 10% of Touche aroma during the summer and a 10-15% of Brasem aroma during the winter.*



## MB 500 CARPA CARASSIO BREME

**CODE: PCBEL03C - 1kg**

Pastura da fondo a grana grossa, di colore marrone scuro, odore e sapore molto dolce con grande potere legante, ottimo per l'aggiunta di esche vive oppure mais e canapa. Normalmente viene usata per la pesca di carpe breme o carassi in acque veloci e medio veloci. Se vogliamo usarla in acque con poca corrente, oppure ferme aggiungere il 20% di torteaux di mais.

*Large grained bottom ground bait, deep brown color, very sweet smell. For its great bending power it can be integrated with live baits, corn and hemp. Really good for bream and crucian fishing in rapidly running waters. Instead to deploy all the potential of this ground bait in still or slow flowing waters you should add a 20% of torteaux corn.*



# NX GENERATION ATOMIC BAIT

## PREMIER CARPA CARASSIO

**CODE: PCBEL03E - 1kg**

Pastura a grana medio grossa, di colore giallo vivo, con potere legante e con sapore ed odore molto dolce, può essere usata benissimo sia in acque veloci che molto lente. E' ideale per la pesca di tutti i pesci di fondo ed in particolare carassi e carpe.

*Medium-large grained ground bait, yellow colored. Good bending power and very sweet taste, it can be used effectively both in running and still waters. It's the ideal for bottom fishing, especially for carps and crucians.*



## BIG FISH YELLOW

**CODE: PCBEL03F - 1kg**

Pastura a grana medio grossa, di colore giallo vivo, molto dolce e con grande potere attrattivo. Ideale per la pesca di grossi pesci di fondo sia in acque ferme che medio veloci. In acqua ferma si consiglia di miscelare la pastura con il 15% di tordeaux di mais per farla disgregare più velocemente e rendere più veloce il potere attrattivo.

*Medium - large grained ground bait, yellow color, sweet and with a great attracting power. Ideal for fishing big bottom water fish, both in current and still waters. For still waters we recommend to mix up Big Fish Yellow with a 15% of tordeaux corn, that will allow a quicker break up, so helping the deploy of all the attracting power of this superb ground bait.*



## BIG FISH RED

**CODE: PCBEL03G - 1kg**

Pastura a grana media, di colore rosso, odore e sapore medio dolce, ha un potere attrattivo molto forte. Questa pastura ha un forte potere legante e può essere arricchita con esche vive come vermi - bigattini oppure con buone quantità di mais e canapa. Ideale per la pesca di tutti i pesci di fondo e in particolare i grossi pesci gatto.

*Medium grained ground bait, red color, moderately sweet smell, with a strong attracting power. It features a great bending power and it can be enriched with alive baits, like worms, or also with corn and hemp. Perfect for fishing all the kinds of bottom fish, catfishes in particular.*

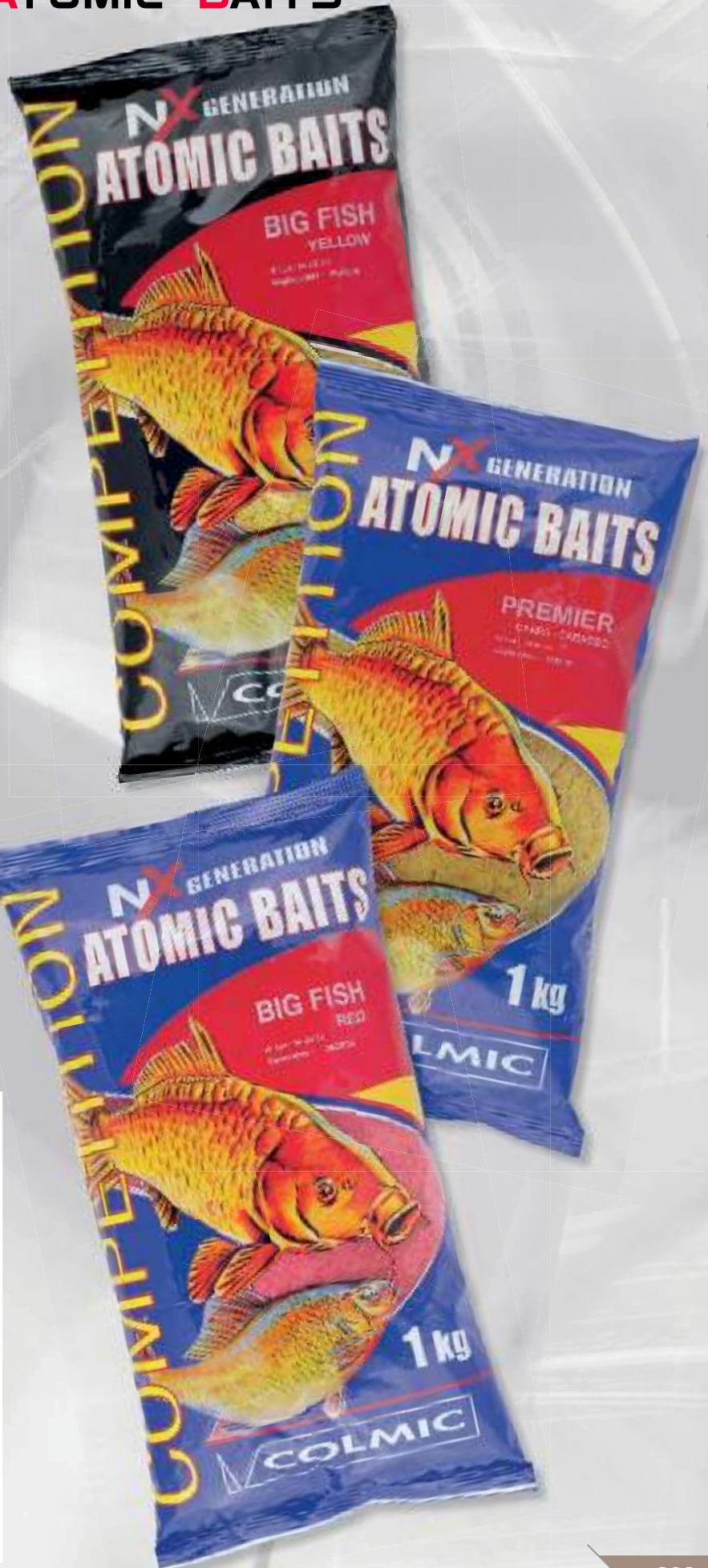

## POWER CARP

**CODE: PC801 - 1kg**

Pastura da fondo a grana media con un potere legante medio di colore nocciola ed un aroma e sapore molto intenso di brasem e vaniglia. E' una pastura fatta con ingredienti di prima qualità molto semplice da bagnare e da utilizzare, ideale per carpe e carassi.

*Groundbait for bottom fishing with a medium composition with a medium- sticky power. Nut color and very strong aroma of brasem and vanilla. This groundbait is composed by high quality ingredients, it is very easy to use and it is ideal for carps and cyprinides.*



## RIVER MAGIC

**CODE: PC802 - 1kg**

Pastura da fondo a grana medio-sottile con un potere legante medio di colore nocciola scuro, un aroma e sapore molto intenso caramello e miele speziato. Anche questa è una pastura fatta con ingredienti di prima qualità molto semplice da bagnare e da utilizzare, ideale per acque a corrente medio veloce per breme, carpe e carassi.

*Groundbait for bottom fishing with a medium- thin composition with a medium- sticky power. Dark- nut colored and very strong aroma of caramel and spiced honey. This groundbait is composed by high quality ingredients, it is very easy to use and it is ideal for running waters and to catch bremes, carps and cyprinides.*



## BLACK

**CODE: PCBEL031 - 1kg**

Pastura da fondo a grana medio fine di colore nero. E' ideale in acqua ferma e corrente. Ideale per la pesca di peci molto sospettosi, grosse breme carassie e gardon. Si consiglia l'aggiunta di un 10 - 15% di additivo green aroma nei mesi invernali e l'additivo rose aroma nei mesi estivi.

*Medium-fine grained bottom ground bait, black colored. It's perfect both for running and still water. We recommend to add a 10 - 15% of Green Aroma during the winter and of Rose aroma during the summer.*



## BREME

**CODE: PCBEL03H - 1kg**

Pastura da fondo a grana medio - fine di colore ambrato chiaro studiata per attirare bream di grossa taglia in acqua ferma e corrente. Si consiglia di aggiungere il 10% di additivo green aroma nei mesi invernali e l'additivo rose aroma nei mesi estivi e primaverili.

*Medium-fine grained for bottom fishing, light amber color, especially conceived to attract big breams both at still and running waters. We recommend to add a 10% of Green aroma during the winter and the Rose aroma during spring and summer.*



# NX GENERATION ATOMIC BAITS



# NX GENERATION ATOMIC BAIT

## QUEEN CARPA

**CODE: PC809 - 1kg**

Pastura da fondo a grana media ideale per la pesca a carpe e carassi di grossa taglia di colore naturale ed aroma di panettone dolce. Ha un potere legante medio e può essere utilizzata sia in acque ferme sia in acque correnti. Può essere integrata con bigattini mais e casters per aumentare il suo forte potere attrattivo.

*It's a natural ground bait with a medium grain, it's ideal for the fishing of big size carps and crucians. It has a sweet cake flavor with a medium clumping. It can be used both in still water and in current water. It can be mixed up with corn and casters to increase its attractive power.*



## CAVEDANO FIUME

**CODE: PC805 - 1kg**

Pastura da fondo a grana media dal colore naturale con un gradevole aroma e sapore di formaggio. E' ideale per insidiare tutti i ciprinidi in fiumi con acque ossigenate, in particolare cavedani, savette, pighi, barbi e scardole. Può essere utilizzata anche per il trasporto di esche sul fondo visto la forte tenacità.

*It's a natural color ground bait which has a medium grain together with a pleasant cheese flavor. It's ideal to mine all the Cyprinids in oxygenated rivers, suitable for chubs, barbells and rudds. It can be used even for the baits carriage to the bottom, considering its attractiveness.*



## BARBO CARASSIO ROSSA

**CODE: PC807 - 1kg**

Miscela creata con farine di primissima qualità per la pesca in fiume di colore rosso. Ha una grana media un forte potere legante ed un aroma e sapore di formaggio molto gradito a tutti i ciprinidi. E' particolarmente indicata anche quando le acque non sono molto limpide. E' capace di trasportare sul fondo una buona quantità di esche aggiunte.

*It's a red ground bait made of high quality flours suitable for the river fishing. It has a medium grain and a great clumping power with an attractive cheese flavor for the Cyprinids. It's particularly indicated even when the water is not such as clear. This ground bait is able to transport to the bottom other baits as well.*





## VELOX CONCORDE

**CODE: PC30A - 1kg**

Pastura da superficie a grana molto fine particolarmente indicata per la pesca d'alborelle in canali o laghi con poca corrente e scarsa ossigenazione. Colore nocciola chiaro ed aroma intenso. Molto facile da utilizzare si stacca bene dalla mano e crea una macchia molto persistente.

*An extremely fine-grained surface groundbait which is particularly suitable for bleak fishing in channels or ponds, with little current and low oxygenation. Light brown colour and intense aroma. Extremely easy to use, this product does not stick to the hands and creates a long lasting cloud.*



## ALBORELLA EXTRA GOLD

**CODE: PC30 - 1kg**

Pastura da fondo a grana medio-fine Pastura da superficie a grana molto fine particolarmente indicata per la pesca d'alborelle in canali o laghi con poca corrente e scarsa ossigenazione. Colore nocciola chiaro ed aroma intenso di crisalide. Questa pastura ha un potere incredibilmente attraente causato da un effetto nuvola molto persistente. Aroma crisalide che prevale sulla lacto vaniglia.

*Ultra-fine textured surface groundbait for bleak fishing in slow moving and badly oxygenated canals or lakes. Light hazel colour and strong chrysalis flavour. Produces a long-lasting cloud effect that has an incredible power of attraction. Chrysalis flavour prevailing over milk and vanilla.*



## PESCHIERA

**CODE: PC63 - 1kg**

Ha un colore naturale chiaro, una grana grossa ed un aroma di crisalide che prevale sul formaggio. Se è inumidita molto si ottiene un impasto molto tenace e pesante ideale per acque veloci. Studiata per barbi, cavedani, savette e scardole.

*Coarse-textured groundbait with a light natural colour and a chrysalis flavour prevailing over the cheese taste. When wetted the mix gets hard and heavy which makes it perfect for fast moving waters. Intended for barb, chub and rudd.*



## FONDO CEFALO

**CODE: PC55F - 1kg**

Pastura prodotta con farine di primissima qualità a grana fine a base di formaggio piccante appositamente studiata per la pesca al cefalo. Di colore chiarissimo può essere impiegata anche come esca sull'amo. È adatta per la pesca in acqua dolce e salata.

*This light-coloured, fine-textured groundbait is produced from a mix of high-grade feed with a pungent cheese flavour, specially designed for grey mullet fishing. It can also be used as a paste and baited directly onto the hook. It is suitable for both fresh and saltwater.*

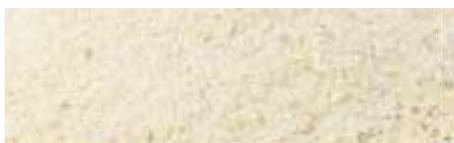

## SARAGO ORATA

**CODE: PC55D - 1kg**

Sfarinato a base di pura farina di sardine di primissima qualità che, una volta bagnata e lavorata, emana il caratteristico odore irresistibilmente invitante per i saraghi, le orate, gli sgombri, le boghe e le occhiate. Per la preparazione basta aggiungere allo sfarinato un'adeguata quantità d'acqua. Può essere usata per la preparazione del pasterello.

*Meal based on first-rate pure pilchard which when wetted and worked, releases its characteristically irresistible scent, which is extremely inviting for white breams, gilt-head breams, mackerels, bogues and saddled breams. To prepare the groundbait just add a little water to the meal. Can be used as hook tying paste.*



## CEFALO COMPETIZIONE

**CODE: PC55G - 1kg**

Simile alla Cefalo, ma con un potere meno legante questa pastura è realizzata con farine di primissima qualità a grana fine a base di formaggio piccante appositamente studiata per la pesca al cefalo. Di colore chiarissimo può essere impiegata anche come esca sull'amo. È adatta per la pesca in acqua dolce e salata.

*This light-colored, fine-textured ground bait is produced with a mix of high-grade feed with a pungent cheese flavor, specially conceived for grey mullet fishing. It can also be used as a paste and baited directly onto the hook. It is suitable for both fresh and Salt water.*

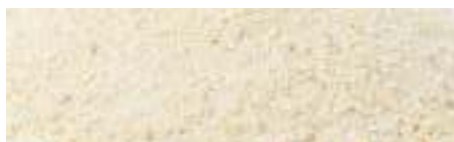

## OCCHIATA SARAGO

**CODE: PC55E - 1kg**

Sfarinato con altissima percentuale di formaggio di primissima scelta, dall'intenso e caratteristico profumo che si esalta una volta che la pastura viene bagnata e lavorata. Pastura per la pesca del sarago, studiata e messa a punto da anni di agonismo ad altissimi livelli. Ottima anche per altri pesci quali salpe e boghe. Opportunamente bagnata, può essere anche innescata.

*Meal based on a high percentage of high quality cheese releasing an intense and particular scent that intensifies when the groundbait is wetted and worked. Groundbait for white breams, developed and tested throughout years of top-level competitions. Excellent also for the fishing of bogues, saddled breams and saupes. When wetted it can also be used as bait.*



# MASTER SERIES

## MASTER SERIES

Se è vero che l'unione fa la forza, l'azienda Colmic è orgogliosa di presentarvi una nuova serie di pasture concepite dal campione tedesco Vincenzo Natale e del campione del mondo Jacopo Falsini. Composte da ingredienti di altissima qualità sono ideali per attrarre ciprinidi, specialmente le Bream. Le pasture della linea Master Series possono essere miscelate fra di loro, per ottenere un colore più idoneo al fondo o cambiarne la consistenza. Per le gare si consiglia di setacciare la pastura bagnata. Per aumentarne il potere attrattivo è possibile aggiungere esche da innesco. Pasture da campioni e per quelli che lo vogliono diventare!

*Unity is strength, and Colmic is proud to introduce a new series of groundbaits created by the German champion Vincenzo Natale and world champion Jacopo Falsini. Made of ingredients of highest quality, they are ideal to attract Cyprinids, especially Bream. Different groundbaits of the Master Mix series can be mixed together to achieve a colour more suitable for the bottom or to change the consistency. In competitions we recommend sifting the wet groundbait. To enhance its attractiveness it is possible to add hook baits. Groundbaits for champions and for who wants to be one!*

## XTREME MATCH

CODE: PCMS01 - 1kg

Pastura a grana media con un potere legante medio, dopo la bagnatura si presenta con un colore nocciola scuro. Questa pastura, grazie alle sue farine di altissima qualità unite ad aromi microcapsulati selezionati, sprigiona un intenso sapore attrattivo gradito moltissimo a Breme, Gardon tutti i ciprinidi in generale. Questa Pastura si può impiegare tutto l'ann; è ottima per canali e acque con corrente medio veloci. Può essere utilizzata pura, oppure tagliata con della terra quando si aggiunge il foulles. La bagnatura è semplice e può essere combinata con altre pasture.

*Medium grain groundbait with medium clumping power, when wet it takes a dark hazel colour. This groundbait, thanks to the highest quality of its flours and selected micro-encapsulated flavours, releases a strong attractive scent especially appreciated by Bream, Gardon and all Cyprinids in general. This groundbait can be used all year long; it is excellent for canals and medium-fast running water. Can be used alone, or mixed with sand when adding jokers. Easy to wet and can be combined with other types of bait.*

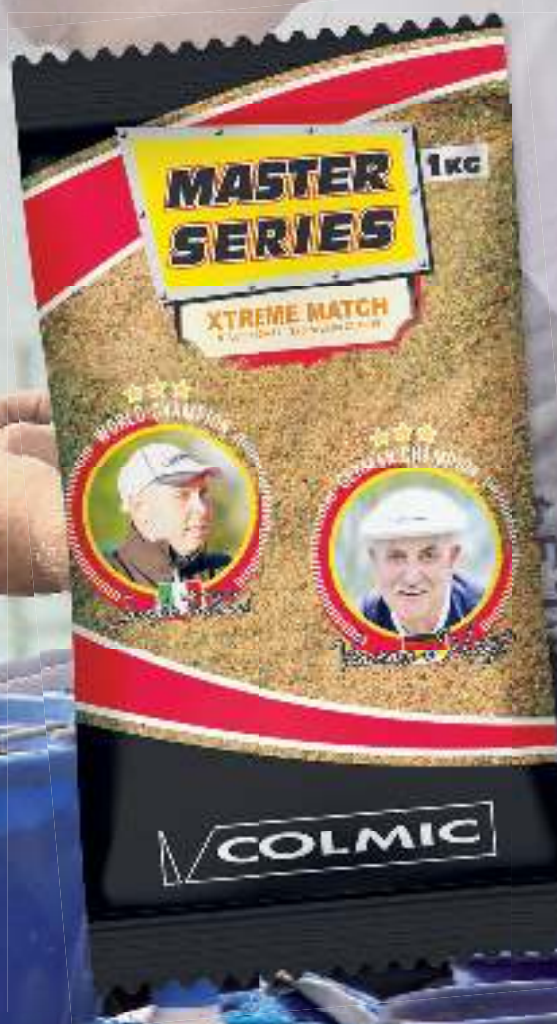
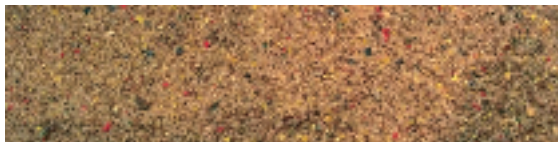



## MATCH WINNER

Code: PCMS03 - 1kg

Pastura a grana medio grossa, molto efficace nella pesca a tutti i Ciprinidi. Ha un sapore dolce speziato al caramello, un ottimo potere legante e grazie alla sua tenacità può essere arricchita con esche vive, specialmente se si pesca con Bigattini, Casters e Lombrichi. E' una pastura ideale quando la pescosità è molto elevata ed occorre selezionare la taglia. Questa specifica miscela è stata messa a punto grazie a tantissimi anni di esperienza.

*Medium-coarse grain groundbait, very effective for all Cyprinids family. It has a sweet spicy caramel taste, excellent clumping and thanks to its tenacity it can be enriched with live bait, especially while fishing with maggots, casters and earthworms. It is an ideal groundbait when angling in abundance of fish and one needs to make choices based on size. Many years of experience have contributed to fine tuning this mixture.*



## IMPRESSIVE MIX

Code: PCMS02 - 1kg

È una pastura che è stata studiata e messa a punto in moltissimi anni di prove su tutti i campi gara del centro e nord Europa per la pesca di Breme e Gardon. Come tutta la gamma Master Series, sono state impiegate solo delle farine di prima scelta e aromi naturali di altissima qualità. Questa pastura può essere tagliata con della terra in qualsiasi percentuale è la pastura ideale per pesche difficili quando è consentito l'utilizzo di fouilles in pastura ed il ver de vase per innesco. La sua efficacia è stata dimostrata in tantissimi campi di gara internazionali garantendo sempre ottimi risultati. Si può utilizzare tutto l'anno e può essere combinata ad altre pasture della gamma Master Series, specialmente alla Xtreme Match.

*This ground bait has been created and fine-tuned over many years of trials throughout all central and northern Europe Bream and Gardon angling competitions. As for each item of the Master Series range, only first choice flours and the highest quality natural flavourings were selected. This groundbait can be mixed with any percentage of sand, it is the ideal groundbait for difficult angling when the use of joker in chumming and hooking bloodworms are allowed. Its effectiveness has been proved in many international competitions and always leads to excellent results. It can be used all year long and it can be combined with other Master Series groundbait products, especially with Xtreme Match.*



**WONDER BAIT BREME**

**CODE: PCBEL15 - 1kg**

Pastura da fondo ideata per la pesca in canale con corrente medio veloce. Ha un buon potere legante ed una grana medio sottile. E' stata appositamente realizzata per la pesca di bream di taglia media. Può essere mescolata con altre pasteure Champions feed.

*Ground bait created for bottom fishing in canals and rivers with medium fast currents. It has a good binder and with a medium thin grain. Specifically designed for medium sized bream. It can be mixed with other Champions feed ground bait.*



**SPEEDO**

**CODE: PCBEL10 - 1kg**

Pastura da fondo che lavora molto rapidamente. Usandola in acque correnti e profonde può essere integrata con terra di riviere. Miscelandola con altre pasteure più leggere della gamma Champion Feed si otterrà una miscela ideale per la pesca in canali con correnti lente e nei laghi.

*Bottom ground bait which breaks up rapidly. To use it in moving and deep waters we suggest to enrich it with Riviere sand. Mixing it with lighter Champion Feed groundbaits you'll get a mixture designed for canal and small lakes fishing with slow waters.*



**WONDER BLACK**

**CODE: PCBEL13 - 2kg**

"Il miracolo nero" è una pastura adatta sia per acque profonde e poco profonde, per correnti forti e deboli. Questa pastura attirerà al vostro amo sia breme che gardon. Anche se è nata come pastura da utilizzare d'inverno, molti pescatori hanno dimostrato la sua efficacia durante tutto l'anno. Può essere combinata ad altre pasteure Champion Feed.

*"The black wonder" is an all-purpose ground bait for all kind of depths, for rapid and slow currents. This groundbaits attracts bremes and gardons. Projected to be used in winter many fishermen tested it all the year long conforming its validity. It can be mixed with other Champion Feed ground baits.*



CHAMPION FEED





## TOUCHE AROMA

**CODE: PCBEL18 - 250gr**

Additivo dal colore arancio per la bream, intergato alle pasture ha una resa maggiore nel periodo estivo. Dose consigliata da 5% a 10% max.

*Orange colour additive to be used with Bream mixes. When mixed with ground bait it offers an higher performance especially during the summer months. Recommended dosage from 5% to a maximum of 10%.*

## CAMEL AROMA

**CODE: PCBEL17 - 250gr**

Additivo creato per grosse bream capace di attirare tutti i pesci di grossa taglia. Ha un aroma dolce ed un sapore salato. Si può utilizzare per integrare alle pasture tutto l'anno. Dose consigliata da 5% a 10% max.

*This additive created for big bream is able to attract any big sized fish. It has a sweet aroma and a salty taste. Can be integrated to ground bait all year round. Recommended dosage: from 5% to a maximum of 10%.*

## GREEN AROMA

**CODE: PCBEL19 - 150gr**

Additivo dolcificante super concentrato all'aroma di vaniglia e pistacchio. Ideale da aggiungere alla pastura in autunno ed in primavera per selezionare grosse bream e gardon. Può essere impiegato anche per aromatizzare i bigattini.

*Highly concentrated sweetening additive with vanilla and pistachio flavouring. It is ideal for mixing with ground bait during the autumn and spring seasons to select big bream and roach. Can also be used flavouring maggots.*

## ROSE AROMA

**CODE: PCBEL20 - 150gr**

Additivo dolcificante super concentrato dal colore rosa all'aroma tutti frutti. Ideale da aggiungere alla pastura nel periodo estivo per selezionare grosse bream. Può essere impiegato anche per aromatizzare i bigattini.

*Highly concentrated sweetening additive. Pink colour with a fruit aroma. It is suggested for mixing with ground bait during the summer season in order to catch big bream. Can be also used for flavouring maggots.*

## STRAWBERRY AROMA

**CODE: PCBEL16 - 250gr**

Additivo concentrato all'aroma di fragola, integrato alle pasture è capace di attirare carpe e pesci di grossa taglia. Si consiglia l'impiego tutto l'anno. Dose consigliata da 5% a 10% max.

*Concentrated additive with strawberry aroma. When integrated into other ground baits it is able to attract carp and big sized fish. It can be used all year round. Recommended dosage from 5% to a maximum of 10%.*

## P.V.1

**CODE: PCBEL21 - 1Kg**

Ingrediente con altissimo potere legante e valore nutritivo non tanto elevato. Si utilizza frequentemente quando si vuole rendere la pastura più tenace per garantire il trasporto di molte esche vive aggiunte sul fondo.

*Highly-binding ingredient with a low nutritional value. Used to make groundbait hard enough to carry plenty of live-baits to the bottom.*

## TTX MAIS

**CODE: PCBEL22 - 1Kg**

Ingrediente utilizzato nella preparazione delle pasture ottenuto dalla parziale disoleazione del mais. Molto apprezzato dai pesci di grossa taglia ha un buon valore nutritivo ed uno scarso potere legante.

*Sweet-corn. Attracts particularly bigger fish, has a good nutrient content and a low binding power.*



**LIGHT DAMP LEAM**

**CODE: PCBEL50A - 2kg**

Terra di somma con basso potere legante molto sottile e soffice anche quando viene inumidita ulteriormente. Può essere impiegata da sola oppure aggiunta alle pasture. Si consiglia l'impiego in acque con poca corrente.

*It's a low power clumping fine and soft leam even when it's damped furtherly. It can be used on its own or added to the groundbaits. To be used with slow waters.*



**BLACK LIGHT DAMP LEAM**

**CODE: PCBEL50B - 2kg**

Terra di somma di colore nero con basso potere legante molto sottile e soffice anche quando viene inumidita ulteriormente. Può essere impiegata da sola oppure aggiunta alle pasture. Si consiglia l'impiego in acque con poca corrente.

*It's a black low power clumping very fine and soft leam, even when it's damped furtherly. It can be used on its own or added to the groundbait. To be used with slow waters.*



**DARK BROWN HEAVY DAMP LEAM**

**CODE: PCBEL50C - 2kg**

Terra molto pesante colorata con un mix di colori nero e marrone ad alto potere legante. Può essere usata da sola oppure in aggiunta alle pasture per aumentare il loro peso specifico e ridurre il valore nutritivo.

*It's a dark brown heavy leam, colored by a mixture of black and brown, it has an high power clumping. It can be used on its own or added to the groundbait to increase its specific weight and to reduce the nutrition level.*







## GREY DRY LEAM

**CODE: PCBEL50E - 1kg**

Terra grigia disidratata con altissimo potere legante. Può essere impiegata per aumentare il potere legante delle terre oppure per incollare il foulles.

*It's a grey leam with a high power clumping. It can be used to augment the binding of the other leams or to glue the jokers.*



## DRY LEAM

**CODE: PCBEL50D - 1kg**

Terra di somma disidratata, ideale per scollare il foulles prima di mescolarlo con terre e pasture.

*It's a dehydrated leam, ideal to unstick the jokers before to mix it with the other leams and groundbaits.*



## TERRA DI FIUME

**CODE: PCI260C - 2kg**

Terra molto pesante, già inumidita, di colore scuro con un grande potere legante. Può essere impiegata da sola con l'aggiunta di esche oppure integrata con la pastura per appesantirla ed ancorarla bene sul fondo.

*An extremely heavy soil, already dampened, with a dark colour and excellent binding power. Can be used on its own with live bait or else integrated with groundbait to weight it and anchor it to the bottom.*





## TERRA DI FONDO BROWN

**CODE: PC005 - 1kg**

Speciale terra disidratata ma ancora più legante da aggiungere a pastura o terra per aumentarne la tenacità. È usata anche per incollare fouillis.

*Special dehydrated clay with high binding power. It's added to groundbait or earth to increase their tenacity. Also used to stick fouillis.*



## GARNET

**CODE: PCA87 - 1kg**

Minerale d'alto peso specifico ideale per appesantire terre e pasture in acque veloci.

*Mineral with an high specific weight in order to make groundbait heavy for rapid waters.*

# EXCLUSIVE DISTRIBUTION



## PAUWELS DAMP LEAM

**CODE: PCBEL01 - 2kg**

È una terra di somma molto particolare, sottilissima, si mantiene soffice e si riesce a setacciare anche dopo che è stata inumidita ulteriormente. Può essere impiegata da sola oppure può essere aggiunta alle pasture per appesantirle e per aumentare il loro potere attrattivo. Colore nocciola chiaro.

*This is a very special, very fine terre de somme leam. It stays soft and can be sifted even after it has been further moistened. Can be used on its own or added to groundbaits to make them heavier and increase their power of attraction. Colour pale hazel.*

## PAUWELS BLACK DAMP LEAM

**CODE: PCBEL02 - 2kg**

È una terra di somma molto particolare, sottilissima. Si mantiene soffice e si riesce a setacciare anche dopo che è stata inumidita ulteriormente. Può essere impiegata da sola oppure può essere aggiunta alle pasture per appesantirle e per aumentare il loro potere attrattivo creando un tappeto sul fondo dove i pesci amano grufolare nella ricerca delle esche. Colore nero.

*This is a very special, very fine terre de somme leam. It stays soft and can be sifted even after it has been further moistened. Can be used on its own or added to groundbaits to make them heavier and increase their power of attraction by creating a carpet on the bottom where the fish like to root around in search of bait. Color Black.*



## GOMMA ARABICA

**CODE: COL6 - 350gr / CODE: COL8 - 600gr (bag)**

Collante per bigattini di incredibile potere addensante. Si differenzia dagli altri collanti in quanto mantiene le larve incollate senza cedere umidità anche a temperature esterne elevate.

*Arabic Gum is a maggot glue that has an incredible thickening power. Unlike the other kinds of binder this glue keeps the maggots together without releasing moisture even at high outside temperatures.*



## STABILIX MAGGOTS

**CODE: COL9R - 500gr (bag)**

Integratore universale di collanti per bigattini. Ha la proprietà di mantenere inalterato il grado d'umidità dei bigattini incollati anche in condizioni atmosferiche avverse.

*All round supplement for maggot glue. Stablix Maggots allows the degree of humidity of the glue maggots to remain unchanged even in different atmospheric conditions.*

## SB-COLORS

**CODE: PCBEL21D - 100gr**

La pastura con il colorante giallo attira carassi, carpe e breme e crea un effetto nuvola per la pesca delle alborelle.

*Yellow attracts crucians, carps and breams. It makes a cloud effect particularly good for bleaks fishing.*

**CODE: PCBEL21B - 100gr**

La pastura con il colorante rosso attira i pesci quando l'acqua diventa sporca. Ideale per savette cavedani e muggini.

*Red attracts fish in cloudy water. Ideal for chub and mullets.*

**CODE: PCBEL21A - 100gr**

La pastura con il colorante colorante Bianco per la pesca di alborelle e per la pesca in mare in superficie.

*White colorant for bleak fishing and surface fishing at sea.*

**CODE: PCBEL21C - 100gr**

Nero per scurire le pasture per la pesca di grossi gardon, e tutti i pesci molto sospettosi.

*Black in order to darken the groundbait for gardon fishing and for wary fish in general.*



# HIGH QUALITY SWIVELS



## GM1707

Barrel swivel gun smoke



CODE	Size	Test Power	
		Kg	Lbs
GM170702	2	46	106
GM170704	4	30	69
GM170706	6	27	62
GM170708	8	20	46
GM170710	10	16	37
GM170711	11	15	36
GM170712	12	14	35
GM170714	14	10	23
GM170716	16	8	18
GM170718	18	7	16
GM170720	20	6	14



## GM1007

Double colour rolling swivel gold ring + gun smoke roller



CODE	Size	Test Power	
		Kg	Lbs
GM100716	16	22	51
GM100718	18	19	44
GM100720	20	14	32
GM100722	22	9	21
GM100724	24	4	9



## GM1003

Diamond eye rolling swivel gun smoke



CODE	Size	Test Power		PCS
		Kg	Lbs	
GM100306	6	47	108	6
GM100308	8	40	92	6
GM100310	10	32	74	12
GM100312	12	30	69	12
GM100314	14	22	51	12
GM100316	16	19	44	12
GM100318	18	14	32	12
GM100320	20	9	21	12
GM100322	22	7	16	12
GM100324	24	4	9	12



## GM1001

Rolling swivel gun smoke



CODE	Size	Test Power		PCS
		Kg	Lbs	
GM100106	6	60	138	6
GM100108	8	43	99	6
GM100110	10	35	81	12
GM100112	12	32	74	12
GM100114	14	30	69	12
GM100116	16	22	51	12
GM100118	18	19	44	12
GM100120	20	14	32	12
GM100122	22	9	21	12
GM100124	24	4	9	12
GM100122A	22	9	21	100
GM100124A	24	4	9	100



## GM1045

High speed double rolling swivel gun smoke



CODE	Size	Test Power	
		Kg	Lbs
GM104514	14	30	69
GM104516	16	22	51
GM104518	18	19	44
GM104520	20	14	32
GM104522	22	9	21
GM104524	24	4	9



## GM1046

High speed triple rolling swivel gun smoke



CODE	Size	Test Power	
		Kg	Lbs
GM104614	14	30	69
GM104616	16	22	51
GM104618	18	19	44
GM104620	20	14	32
GM104622	22	9	21
GM104624	24	4	9



## GM1804

Ball bearing swivel with solid ring gun smoke



CODE	Size	TestPower		PCS
		Kg	Lbs	
GM180400	0	15	35	6
GM180401	1	20	46	6
GM180402	2	25	58	6
GM180403	3	35	81	6
GM180404	4	50	115	5
GM180405	5	65	150	5
GM180406	6	80	184	5
GM180407	7	100	230	3
GM180408	8	125	288	3



## GM1012

Side line rolling swivel gun smoke



CODE	Size	TestPower	
		Kg	Lbs
GM101214	14	30	69
GM101218	18	19	44



## GM2018

"Q" shaped snap with swivel gun smoke



CODE	Size
GM201810	10
GM201812	12
GM201814	14



# SWIVELS - HIGH QUALITY

## GM3002

Rolling swivel with interlock snap gun smoke



CODE	Size	Test Power		PCS
		Kg	Lbs	
GM300200	0	60	132	6
GM300202	2	43	95	6
GM300204	4	25	55	6
GM300206	6	25	55	6
GM300208	8	18	40	6
GM300210	10	18	40	12
GM300212	12	14	31	12
GM300214	14	14	31	12
GM300216	16	12	26	12
GM300218	18	12	26	12
GM300220	20	7	15	12
GM300222	22	7	15	12
GM300224	24	7	15	12



## GM3701

Barrel swivel with safety snap gun smoke



CODE	Size	Test Power	
		Kg	Lbs
GM370101	1	34	78
GM370102	2	15	35
GM370104	4	15	35
GM370106	6	13	30
GM370108	8	9	21
GM370110	10	9	21
GM370112	12	7	16
GM370114	14	7	16
GM370116	16	5	12
GM370118	18	5	12
GM370120	20	5	12



## GM3006

Rolling swivel with insurance snap gun smoke



CODE	Size	Test Power		PCS
		Kg	Lbs	
GM300601	1	70	161	6
GM300602	2	55	127	6
GM300604	4	55	127	12
GM300606	6	40	92	12
GM300608	8	40	92	12
GM300610	10	30	69	12
GM300612	12	30	69	12
GM300614	14	15	35	12
GM300616	16	15	35	12
GM300618	18	10	23	12
GM300620	20	10	23	12
GM300622	22	6	14	12
GM300624	24	4	9	12



## GM3003

Rolling swivel with hooked snap black



CODE	Size	Test Power		PCS
		Kg	Lbs	
GM300300	0	60	132	6
GM300302	2	45	99	6
GM300304	4	40	88	6
GM300306	6	40	88	6
GM300308	8	35	77	6
GM300310	10	35	77	12
GM300312	12	28	62	12
GM300314	14	28	62	12
GM300316	16	20	44	12
GM300318	18	20	44	12
GM300320	20	12	26	12
GM300322	22	12	26	12
GM300224	24	9	20	12



## GM3035

High speed double rolling swivel with insurance snap gun smoke



CODE	Size	Test Power		PCS
		Kg	Lbs	
GM303501	1	70	161	6
GM303504	4	55	127	12
GM303516	16	15	35	12
GM303518	18	10	23	12
GM303520	20	10	23	12
GM303524	24	4	9	12



## GM3806

Ball bearing swivel with two solid rings with insurance snap black



CODE	Size	Test Power		PCS
		Kg	Lbs	
GM380600	0	10	23	6
GM380601	1	15	35	6
GM380602	2	30	69	6
GM380603	3	45	104	6
GM380604	4	55	127	5
GM380605	5	70	161	5
GM380606	6	90	207	5



## GM3807

Ball bearing swivels with two solid rings with costlock snap gun smoke



CODE	Size	Test Power		PCS
		Kg	Lbs	
GM380700	0	8	18	6
GM380701	1	14	32	6
GM380702	2	22	51	6
GM380703	3	35	81	6
GM380704	4	45	104	5
GM380705	5	55	127	5
GM380706	6	70	161	5



## GM3017

Rolling swivel with hanging snap



CODE	Size	Test Power	
		Kg	Lbs
GM301702	2	23	52
GM301704	4	18	40
GM301706	6	14	32
GM301708	8	10	23
GM301710	10	5	12



## GM5007

Moved plastic head with safety gun smoke



CODE	Size
GM500706	6
GM500708	8



## GM4032

Diamond rolling swivel with nice snap and butterfly plastic head gun smoke



CODE	Size
GM4032A	A



## GM4033

Diamond impressed rolling swivel with hooked snap and black tube gun smoke



CODE	Size
GM4033A	A



## GM1025

Cross line brass head and tube black



CODE	Size	Test Power	
		Kg	Lbs
GM102505	5	32	74
GM102507	7	22	51
GM102510	10	19	44
GM102512	12	14	32



## GM1027

Crossline rolling with pearl nickel beads



CODE	Size	Test Power	
		Kg	Lbs
GM102706	2/0*1/0	60	134
GM102705	1*2	43	96
GM102704	3*4	35	78
GM102703	5*6	30	67
GM102702	7*8	19	43
GM102701	10*12	9	20



## GM1026

Cross line fluorescent beads with nickel swivel



CODE	Size
GM10261S	S



## GM1064

Fluorescent beads with cross line bead and tube gun smoke



CODE	Size	/Omm
GM106403	3	I.D./0.4
GM106407	7	I.D./0.8
GM106412	12	I.D./1.55



## GM0001

Rolling swivel with insurance snap gun smoke



CODE	Size
GM000112	12
GM000114	14
GM000116	16



## GM0002

One side back snap swivel with hole gun smoke



CODE	Size
GM000212	12
GM000214	14
GM000216	16



## GM9001

Heat-shrinking rubber snap

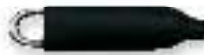

CODE	Size
GM90011L	L
GM90012M	m
GM90013S	s



## GM2026

Hawaii snap gun smoke



CODE	Size	Test Power	
		Kg	Lbs
GM202601	1	9	21
GM202602	2	12	28
GM202603	3	20	46



## GM2006

Insurance snap nickel



CODE	Size	Test Power	
		Kg	Lbs
GM200600	0	10	22
GM200601	1	15	33
GM200602	2	30	66
GM200603	3	40	88
GM200604	4	55	121
GM200605	5	70	154
GM200606	6	90	198



## GM2032

Hanging snap nickel



CODE	Size	Test Power	
		Kg	Lbs
GM203200	0	5	11
GM203201	1	10	22
GM203202	2	14	31
GM203203	3	18	40
GM203204	4	23	51
GM203205	5	28	62



## GM6025

Oval split ring nickel



CODE	Size	Test Power	
		Kg	Lbs
GM602510	10	10	22
GM602513	13	18	40
GM602515	15	28	62



# SWIVELS - HIGH QUALITY

## BAIT U-SNAP GM2004



CODE	Size	Test Power	
			Lbs
GM200404	00	14	
GM200400	0	20	
GM200401	1	25	
GM200402	2	35	
GM200403	3	60	



## GM6008

Split rings



CODE	Size	Test Power	
		Kg	Lbs
GM600835	3,5	3	7
GM600840	4	4	9
GM600845	4,5	5	12
GM600850	5	8	18
GM600860	6	12	28
GM600870	7	15	35
GM600880	8	20	44
GM6008A10	10	25	55



## GM6009

Solid rings gun smoke

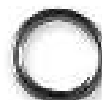

CODE	Size
GM600900	0
GM600901	1
GM600902	2
GM600903	3
GM600904	4
GM600905	5
GM600906	6
GM600907	7

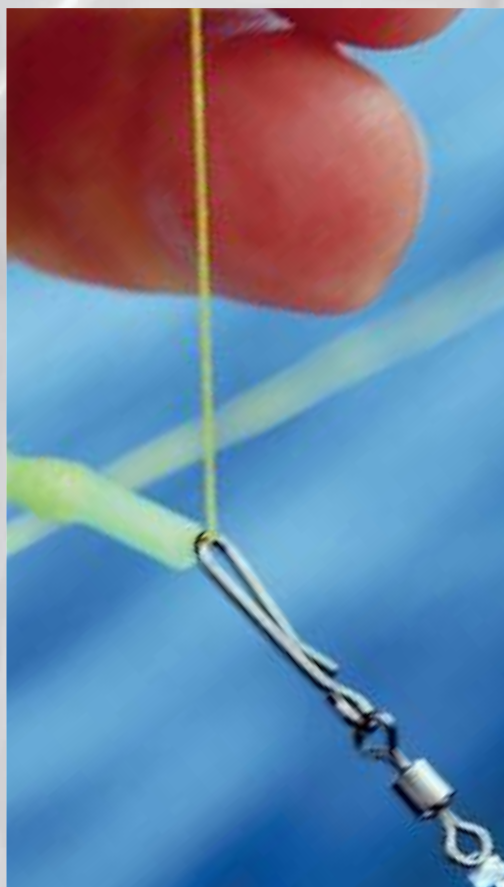

## GM6018

Queste pratiche strisce di piombo sono state ideate per molteplici tipologie di utilizzo. Ottime per la trota torrente come zavorra con la classica pesca al tocco, ma di svariato utilizzo anche per la pescain mare come ad esempio per l'appesantimento dei nostri filetti di sarda o muggine per adagarli in modo più stabile sui fondali.

*These practical lead strips have been designed for many different uses. Excellent for trout fishing in the stream as a weight in classical coarse fishing, and also versatile and useful in various ways in sea fishing, for example as weights for sardine or mullet filets to position them more stably on the sea bed.*



CODE	Size	PCS
GM601810	10	6
GM601813	13	6
GM601817	17	4



## GM6007

Brass tubes gun smoke



CODE	Size cm
GM600706	0,6
GM600708	0,8
GM600710	1,0
GM600712	1,2
GM600714	1,4
GM600716	1,6
GM600718	1,8
GM600720	2,0



## GM6029

Oval aluminum tubes nickel



CODE	I.D.	Size O.D.	L.	Ø nylon
GM602901K	0,8	1,7	6,5	0,45-0,70
GM60290A	1,0	2,0	6,5	0,62-0,90
GM60291B	1,2	2,4	6,5	0,90-1,10
GM60292C	1,4	2,8	6,5	1,00-1,30
GM60293D	1,6	3,2	6,5	1,30-1,55
GM60294E	1,8	3,6	18	1,55-1,66



## GM5016

Rolling swivel with fluorescent beads and oval rubber stoppers.



CODE	Size
GM50161L	L
GM50162M	m
GM50163S	S



## GM5017

Diamond impressed swivel with green beads and stick rubber stoppers



CODE	Size
GM50173L	LL
GM50172L	L
GM50171S	S



## GM4044

"Y" Shape balance with swiveland snap nickel



CODE	Size (cm)
GM404409	9
GM404412	12
GM404415	15



## GM6063

Small style plastic tube balance



CODE	Size
GM606305	55
GM606308	85
GM606312	120



## ANTITANGLE

CODE	size
ANTI1	4 cm
ANTI2	7 cm

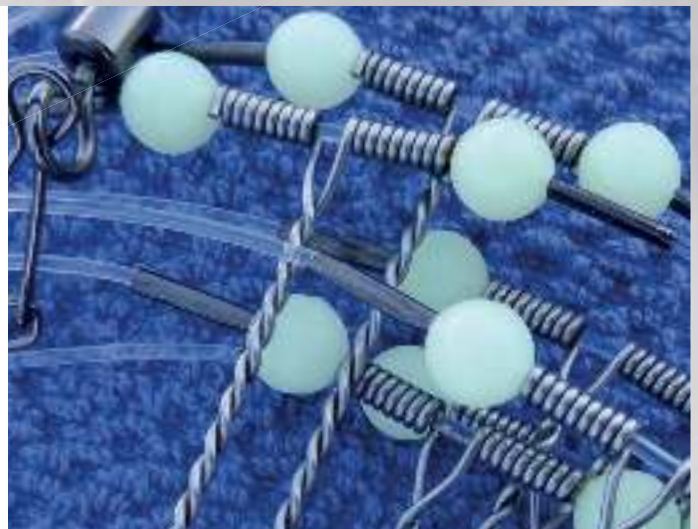
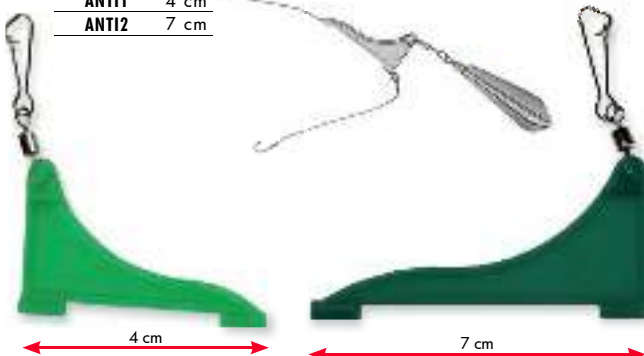





*feeder* **SCRAPE**



*feeder*

## BLACK QUEEN

XT

STRONG - ACTION 2

Canne potenti, rapide e precise, progettate per la pesca agonistica, si esprimono al meglio alle massime distanze e nella pesca in drop back.

*Powerful rods, quick and precise, designed for competitions, they give their best at maximum casting distance and drop back fishing.*

CODE	Length (mt)	Casting W. (gr)	cl.Length (cm)	Weight (gr)	Diameter (mm)	Sections
CABL10A	3,90	40-120	136	245	12,60	3+3Tips
CABL10B	4,15	40-120	145	225	14,10	3+3Tips

CARBON TIP 2 OZ.    
  CARBON TIP 2 - 1/2 OZ.

CARBON TIP 3 OZ.

Series: T

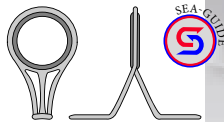

LEG: Medium  
STONE: Sic  
FRAME COLOR: Gun Smoke

Series: OS



LEG: Short  
STONE: Sic  
FRAME COLOR: Gun Smoke

Series: XM



LEG: Micro Guides  
STONE: Sic  
FRAME COLOR: Gun Smoke

**PRO force**  
CARDON Power Double Tape

**U.L.A.F.** ULTRA LIGHT AEROSPACE FIBER

## EXTRA TIPS

### CARBON

- 10Z (CODE: CATIP01)
- 1.1/20Z (CODE: CATIP01A)
- 20Z (CODE: CATIP01B)
- 2.1/20Z (CODE: CATIP01C)
- 30Z (CODE: CATIP01D)
- 40Z (CODE: CATIP01E)

### FIBERGLASS

- 1/20Z (CODE: CATIP02A)
- 10Z (CODE: CATIP02B)
- 1.1/20Z (CODE: CATIP02C)
- 20Z (CODE: CATIP02D)
- 2.1/20Z (CODE: CATIP02E)

# RODS - 3 SECTIONS



PROFESSIONAL FEEDER

# NEXT ADVENTURE

## 3 SECTIONS



Series: T



LEG: Medium  
STONE: Sic  
FRAME COLOR: Gun Smoke

Series: OS

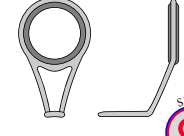

LEG: Short  
STONE: Sic  
FRAME COLOR: Gun Smoke

Series: XM



LEG: Micro Guides  
STONE: Sic  
FRAME COLOR: Gun Smoke

## NEXT ADVENTURE 45GR. - 60GR. (3,60MT)





45gr MEDIUM LIGHT - ACTION 3 / 60gr MEDIUM - ACTION 3

Ideali per la pesca nei canali e in tutte le condizioni di acqua lenta o mediamente veloce, molto pronte nella gestione del pesce anche con lenze leggere.

*Ideal for angling in canals and in all slow or medium-fast water moving conditions, extremely quick in handling the catch also with light lines.*

CODE	Length (mt)	Casting W. (gr)	cl.Length (cm)	Weight (gr)	Diameter (mm)	Sections
CANEX05A	3,60	45	132	210	18,00	3+3Tips
CANEX06A	3,60	60	132	228	18,00	3+3Tips

 CARBON TIP 1 OZ.  CARBON TIP 1 - 1/2 OZ.  
 CARBON TIP 2 OZ.

## NEXT ADVENTURE 90GR. (3,60MT)





MEDIUM POWER - ACTION 3

Una canna hall round molto versatile, ma che ben si adatta anche a una pesca decisamente muscolosa come quella rivolta alla carpa o ai grossi channel cat fish.

*An all-round very versatile rod, but well suited also for heavy-duty angling, such as carp and large channel cat fish.*

CODE	Length (mt)	Casting W. (gr)	cl.Length (cm)	Weight (gr)	Diameter (mm)	Sections
CANEX07A	3,60	90	132	230	18,00	3+3Tips

 CARBON TIP 1 - 1/2 OZ.  CARBON TIP 2 OZ.  
 CARBON TIP 3 OZ.

## NEXT ADVENTURE

60GR. - 90GR. (3,90MT)

KT

MEDIUM POWER - ACTION 1

Versione più lunga delle due sorelle minori, sia la 60 gr. che la 90 gr., fanno della loro azione progressiva quel punto di forza che le rende particolarmente indicate per la pesca in acque correnti.

*Longer version of its two smaller sisters, both the 60 gr. and the 90 gr., have their strength in their progressive action, that makes them particularly suited for running water angling.*

CODE	Length (m)	Casting W. (gr)	cl.Length (cm)	Weight (gr)	Diameter (mm)	Sections
CANEX06B	3,90	60	135	240	18,00	3+3Tips

CARBON TIP 1 OZ. CARBON TIP 1 - 1/2 OZ.

CARBON TIP 2 OZ.

CODE	Length (m)	Casting W. (gr)	cl.Length (cm)	Weight (gr)	Diameter (mm)	Sections
CANEX07B	3,90	90	135	260	18,00	3+3Tips

CARBON TIP 1 - 1/2 OZ. CARBON TIP 2 OZ.

CARBON TIP 3 OZ.

## NEXT ADVENTURE

120GR.-120GR. BARBEL FISHING

KT

STRONG - ACTION 1

Espressamente concepite per la pesca in corrente ai potenti pesci dei grandi fiumi, queste canne si rivelano perfette anche per il feeder fishing in acqua salata.

*Purposely conceived for angling powerful fish in large rivers' streaming water, these rods are perfect also for feeder fishing in salt water.*

CODE	Length (m)	Casting W. (gr)	cl.Length (cm)	Weight (gr)	Diameter (mm)	Sections
CANEX08A	3,90	120	135	280	18,00	3+3Tips
CANEX08B	4,15	120-barbel	145	354	21	3+3Tips

CARBON TIP 2 OZ. CARBON TIP 2 - 1/2 OZ.

CARBON TIP 3 OZ.

## EXTRA TIPS

### CARBON

- 1OZ (CODE: CATIP01)
- 1.1/2OZ (CODE: CATIP01A)
- 2OZ (CODE: CATIP01B)
- 2.1/2OZ (CODE: CATIP01C)
- 3OZ (CODE: CATIP01D)
- 4OZ (CODE: CATIP01E)

### FIBERGLASS

- 1/2OZ (CODE: CATIP02A)
- 1OZ (CODE: CATIP02B)
- 1.1/2OZ (CODE: CATIP02C)
- 2OZ (CODE: CATIP02D)
- 2.1/2OZ (CODE: CATIP02E)

## KRION

STRONG - ACTION 2

Canne rapide e potenti, consigliate per tutti quei casi in cui si preveda una pesca virile o in circostanze di acqua veloce, con lenze pesanti e medio pesanti.

*Fast and powerful rods, for all the situations that call for "manly" angling or in fast moving water, with heavy and medium-heavy lines.*

CODE	Length (m)	Casting W. (gr)	cl.Length (cm)	Weight (gr)	Diameter (mm)	Sections
CAKRI01A	3,60	40-160	126	298	15,70	3+4 TIPS
CAKRI01B	3,90	40-160	136	317	16,20	3+4 TIPS

- CARBON TIP 30Z.**  
CODE: CAKRI01D
- CARBON TIP 50Z.**  
CODE: CAKRI01F
- CARBON TIP 40Z.**  
CODE: CAKRI01E
- FIBER GLASS 1-1/20Z.**  
CODE: CAKRI01C

Series: MH-H

STONE: Sic  
FRAME COLOR: Black

Series: XM

LEG: Micro Guides  
STONE: Sic  
FRAME COLOR: Black



## KRONOS

STRONG - ACTION 1

Canna potente e bilanciata, ideale per le grandi prede. La particolare ripartizione delle sue sezioni e la lunghezza modulabile gli permettono di affrontare qualsiasi ragionevole condizione di pesca.

*Powerful and balanced rod, ideal for big catches. The special sectioning and the adjustable length allow it to handle any reasonable angling condition.*

CODE	Length (m)	Casting W. (gr)	cl.Length (cm)	Weight (gr)	Diameter (mm)	Sections
CAKRI01A	3,60	40-160	120	292	15,20	3+4 TIPS

- CARBON TIP 40Z.**  
CODE: CAKRI01E
- FIBER GLASS 20Z.**  
CODE: CAKRI01C
- CARBON TIP 30Z.**  
CODE: CAKRI01D
- FIBER GLASS 10Z.**  
CODE: CAKRI01B

Series: T

LEG: Medium  
STONE: Sic  
FRAME COLOR: Gun Smoke

Series: XM

LEG: Micro Guides  
STONE: Sic  
FRAME COLOR: Gun Smoke



**SOLD OUT**

**SOLD OUT**

## STRIKE ONE

STRONG - ACTION 2

Consigliata per la pesca a distanza e nelle correnti medio-veloci, la Strike One è una canna pronta e bilanciata, che ben si adatta a anche al feeder fishing in acqua salata.

*Recommended for per la distance fishing and medium-fast currents, Strike One is a ready and balanced rod, well suited also for salt water feeder fishing.*

CODE	Casting	cl.Length (cm)	Weight (gr)	Diameter (mm)	Sections
CAS1		132	295	16,00	3+3 TIPS

FIBER GLASS TIP 2 OZ.

FIBER GLASS TIP 1 OZ.

FIBER GLASS TIP 2 OZ.

**SOLD OUT**



Series: MN-B



STONE: Simil Sic  
FRAME COLOR: Black

Series: XM



LEG: Micro Guides  
STONE: Simil Sic  
FRAME COLOR: Black

Series: MK



LEG: Micro Guides  
STONE: Simil Sic  
FRAME COLOR: Black

## TAUNUS

MEDIUM POWER - ACTION 2

Canna decisamente versatile, molto maneggevole e progressiva, progettata per gestire con successo il recupero di prede importanti anche con impianti di lenza sottodimensionati. Ottima anche per il method feeder pesante.

*Truly versatile rod, extremely handy and progressive, designed to successfully retrieve sizeable catch also with undersized lines setup. Excellent also for heavy feeder method.*

CODE	Length (m)	Casting W. (gr)	cl.Length (cm)	Weight (gr)	Diameter (mm)	Sections
CATA01A	3,60	20-100	128	251	13,70	3+3 TIPS
CATA01B	3,90	20-100	137	314	14,50	3+3 TIPS

CARBON TIP 3.5 OZ.

CARBON TIP 2.5 OZ.

FIBER GLASS TIP 1.5 OZ.



Series: MN-B



STONE: Simil Sic  
FRAME COLOR: Black

Series: OS



LEG: Short  
STONE: Simil Sic  
FRAME COLOR: Black

Series: MK



LEG: Micro Guides  
STONE: Simil Sic  
FRAME COLOR: Black

## METHOD F1

XT

MEDIUM POWER - ACTION 3

Il suo nome dice tutto: un attrezzo specifico destinato a una pesca specifica come solo il method feeder fishing può essere. Potenza ed elasticità sono le sue caratteristiche.

*Its name says it all: a tool specifically designed for a precise type of fishing such as method feeder fishing. Its characteristics are power and flexibility*

CODE	Length (mt)	Casting W. (gr)	cl.Length (cm)	Weight (gr)	Diameter (mm)	Sections
CAME87A	3,30	20-100	118	210	20,90	3+2 TIPS
CAME87B	3,60	20-100	128	240	20,90	3+2 TIPS

FIBER GLASS TIP 3 OZ.

FIBER GLASS TIP 2 OZ.

Series: XT

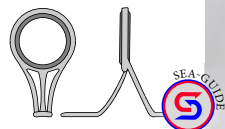

LEG: Micro Guides  
STONE: Sic  
FRAME COLOR: Gun Smoke

Series: XM



LEG: Micro Guides  
STONE: Sic  
FRAME COLOR: Gun Smoke

**PRO force**  
CARBON Power Double Taper

**U.L.A.F.** ULTRA LIGHT AEROSPACE FIBER

**SOLD OUT**

## METHOD

X5

MEDIUM POWER - ACTION 3

Canna specifica destinata a una pesca specifica come solo il method feeder fishing può essere. Potenza ed elasticità sono le sue caratteristiche.

*Designed for a precise type of fishing such as method feeder fishing. Its characteristics are power and flexibility*

CODE	Length (mt)	Casting W. (gr)	cl.Length (cm)	Weight (gr)	Diameter (mm)	Sections
CAME87A	3,30	20-100	118	218	13,80	3+2 TIPS
CAME87B	3,60	20-100	128	246	14,80	3+2 TIPS

FIBER GLASS TIP 3 OZ.

FIBER GLASS TIP 2 OZ.

Series: T

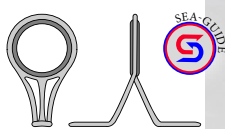

LEG: Medium  
STONE: Sic  
FRAME COLOR: Gun Smoke

Series: OS

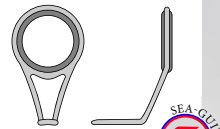

LEG: Short  
STONE: Sic  
FRAME COLOR: Gun Smoke

**U.L.A.F.** ULTRA LIGHT AEROSPACE FIBER

Series: MK



LEG: Micro Guides  
STONE: Sic  
FRAME COLOR: Gun Smoke



## NX-GEN SERIES

X5

STRONG - ACTION 1

Una serie di canne in grado di coprire tutte le esigenze di pesca da ledgering o con il feeder, sia che si tratti di barbel fishing, sia per delle varie tecniche di specialist praticabili nelle correnti importanti dei grandi fiumi.

*This rods' series can cover all ledgering or feeder fishing requirements, either barbel fishing, or the various specialist techniques used in large rivers' powerful streaming water.*

### SNIPER 90GR. - 130GR.

CODE	Length (m)	Casting W. (gr)	d.Length (cm)	Weight (gr)	Diameter (mm)	Sections
CASN10A	3,60	90	126	225	21,30	3+3 Tips
CASN10B	3,60	130	127	254	21,30	3+3 Tips
CASN10C	3,90	130	137	275	21,30	3+3 Tips

CARBON TIP 3 OZ.      CARBON TIP 2 OZ.  
 FIBER GLASS TIP 1 1/2 OZ.

### GHEPARD 90GR. - 120GR.

CODE	Length (m)	Casting W. (gr)	d.Length (cm)	Weight (gr)	Diameter (mm)	Sections
CAGH70A	3,60	90	130	240	21,70	3+3 Tips
CAGH71A	3,90	90	140	260	21,70	3+3 Tips
CAGH70B	3,60	120	130	240	21,70	3+3 Tips
CAGH71B	3,90	120	140	280	21,70	3+3 Tips

CARBON TIP 3 OZ.      CARBON TIP 2 OZ.  
 FIBER GLASS TIP 1 1/2 OZ.

### GHEPARD 150GR. - 180GR.

CODE	Length (m)	Casting W. (gr)	d.Length (cm)	Weight (gr)	Diameter (mm)	Sections
CAGH70C	3,60	150	130	255	21,70	3+3 Tips
CAGH71C	3,90	150	140	295	21,70	3+3 Tips
CAGH71D	3,90	180	140	308	21,70	3+3 Tips

CARBON TIP 4 OZ.      CARBON TIP 3 OZ.  
 CARBON TIP 2 OZ.

Series: T

LEG: Medium  
STONE: Sic  
FRAME COLOR: Gun Smoke

Series: OS

LEG: Short  
STONE: Sic  
FRAME COLOR: Gun Smoke

Series: XM

LEG: Micro Guides  
STONE: Sic  
FRAME COLOR: Gun Smoke



## BLACK STYLE

MEDIUM - ACTION 3

Nata per gestire pesci di taglia, anche con lenze raffinate, la Black Stile è ciò che serve per la pesca in acque ferme o con poca corrente.

*Created to handle sizeable fish, also with refined lines, Black Stile is what is needed for fishing in still water or with very little current.*

CODE	Length (m)	Casting W. (gr)	cl.Length (cm)	Weight (gr)	Diameter (mm)	Sections
<b>CABLO2</b>	3,30	30-80	116	225	15,00	3+2 TIPS
<b>CABLO2A</b>	3,60	30-80	126	245	15,60	3+2 TIPS

 CARBON TIP 2 1/2 OZ.

 FIBER GLASS TIP 1 1/2 OZ.

Series: T

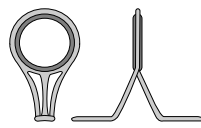

LEG: Medium  
STONE: Simil Sic  
FRAME COLOR: Gun Smoke

Series: OS

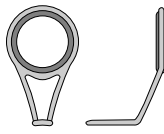

LEG: Short  
STONE: Simil Sic  
FRAME COLOR: Gun Smoke

**SST**  
Hi-Tech  
SUPER SLIDING TOUCH

Series: MK



LEG: Micro Guides  
STONE: Simil Sic  
FRAME COLOR: Gun Smoke

## KABAL

X5

STRONG - ACTION 1

Una serie di canne in grado di coprire tutte le esigenze di pesca a ledgering o con il feeder, sia che si tratti di barbel fishing, sia per delle varie tecniche di specialist praticabili nelle correnti importanti dei grandi fiumi.

*This rods' series can cover all ledgering or feeder fishing requirements, either barbel fishing, or the various specialist techniques used in large rivers' powerful streaming water*

CODE	Length (m)	Casting W. (gr)	cl.Length (cm)	Weight (gr)	Diameter (mm)	Sections
<b>SOLD OUT</b>	3,60	30-80	125	303	15,50	3+3tips
<b>SOLD OUT</b>	3,90	30-80	135	349	16,80	3+3tips

 CARBON TIP 3 OZ.

 FIBER GLASS TIP 2 OZ.

 FIBER GLASS TIP 1 OZ.

CODE	Length (m)	Casting W. (gr)	cl.Length (cm)	Weight (gr)	Diameter (mm)	Sections
<b>SOLD OUT</b>	3,60	50-120	126	303	16,00	3+3tips
<b>CAKA55D</b>	3,90	50-120	137	349	16,80	3+3tips
<b>CAKA55E</b>	4,20	50-120	146	400	17,20	3+3tips

 CARBON TIP 4 1/2 oz.

 FIBER GLASS TIP 3 oz.

 FIBER GLASS TIP 1 1/2 oz.

CODE	Length (m)	Casting W. (gr)	cl.Length (cm)	Weight (gr)	Diameter (mm)	Sections
<b>CAKA55F</b>	3,90	70-160	135	377	17,15	3+3tips
<b>CAKA55G</b>	4,20	70-160	147	436	17,40	3+3tips

 CARBON TIP 4 1/2 oz.

 FIBER GLASS TIP 3 oz.

 FIBER GLASS TIP 1 1/2 oz.

Series: MN

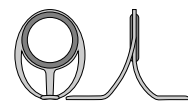

STONE: Simil Sic  
FRAME COLOR: Black

Series: XM



LEG: Micro Guides  
STONE: Simil Sic  
FRAME COLOR: Black

EXTRA TIPS CARBON

 3oz (code: CAKA56C)

 4 1/2oz (code: CAKA56F)

EXTRA TIPS FIBERGLASS

 1oz (code: CAKA56A)

 2oz (code: CAKA56B)

 1.1/2oz (code: CAKA56D)

 3oz (code: CAKA56E)

## VIRTUAL FEEDER

MEDIUM - ACTION 4

Destinata alla pesca con montature medio-leggere, la Virtual Feeder è una canna sensibile e reattiva, ideale per i pesci più difficili, che gestisce al meglio, grazie alla capacità parabolica del suo blank.

*Created for medium-light setups, Virtual Feeder is a sensitive and reactive rod, ideal for hard to catch fish, thanks to its parabolic blank.*

Casting W. (gr)	cl.Length (cm)	Weight (gr)	Diameter (mm)	Sections
20-70	126	240	13,40	3+3 TIPS

**CARBON TIP 3 1/2 oz.**      **CARBON TIP 1 oz.**

**FIBERGLASS TIP 2 oz. 1/2 oz.**

Series: T

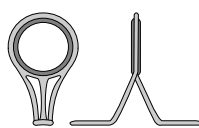

LEG: Medium  
STONE: Simil Sic  
FRAME COLOR: Black

Series: OS

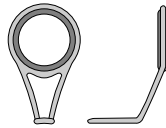

LEG: Short  
STONE: Simil Sic  
FRAME COLOR: Black

Series: XM



LEG: Micro Guides  
STONE: Simil Sic  
FRAME COLOR: Black

**SOLD OUT**

## PREZIOSA

STRONG - ACTION 2

Canna molto potente ed elastica allo stesso tempo, particolarmente indicata per la "caccia grossa" nei grandi fiumi e per il feeder fishing in mare.

*The only Colmic's telescopic feeder; a very powerful and flexible rod, particularly recommended for "big game" in large rivers and feeder fishing at sea.*

CODE	Length (m)	Casting W. (gr)	cl.Length (cm)	Weight (gr)	Diameter (mm)	Sections
CAPRE01A	4,10	100	135	255	19,50	4+3 Tips
CAPRE01B	4,50	130	139	299	20,60	5+3 Tips

**CARBON TIP ACTION MH**      **FIBERGLASS TIP ACTION ML**

**CARBON TIP ACTION H**



Series: T

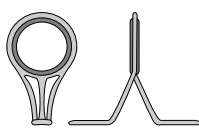

LEG: Medium  
STONE: Simil Sic  
FRAME COLOR: Frosted Silver

Series: OS

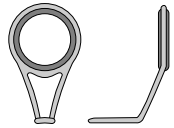

LEG: Short  
STONE: Simil Sic  
FRAME COLOR: Frosted Silver

Series: MK



LEG: Micro Guides  
STONE: Simil Sic  
FRAME COLOR: Frosted Silver

TELE FEEDER

# GOLD LION

## 2 SECTIONS ~~XXT~~

### GOLD LION ~~XXT~~

LIGHT - ACTION 4

Sviluppate in un'ottica spiccatamente agonistica, queste canne sono perfette per la pesca leggera alle corte e medie distanze, nelle acque lente dei nostri campi gara.

*Clearly developed for competitions, these rods are perfect for light fishing in short and medium casting distances, in the slow water of our fishing venues.*

CODE	Length (m)	Casting W. (gr)	cl.Length (cm)	Weight (gr)	Diameter (mm)	Sections
CAG050A	3,30	5-35	175	185	18,60	2+3 TIPS
CAG050B	3,60	10-50	190	190	18,60	2+3 TIPS

 CARBON TIP 1 oz.

 CARBON TIP 2 oz.

 CARBON TIP 1 - 1/2 oz.

**PRO FORCE**  
ULTRA LIGHT  
AEROSPACE FIBER

**ULTRA LIGHT**  
AEROSPACE FIBER

Series: LV



LEG: Medium  
STONE: Alconite  
FRAME COLOR: Black

Series: SV

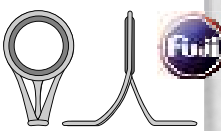

LEG: Medium  
STONE: Alconite  
FRAME COLOR: Black

Series: MK



LEG: Micro Guides  
STONE: Alconite  
FRAME COLOR: Black

## 2 SECTIONS HIGH PERFORMANCE

### PRO FEED

MEDIUM - ACTION 3

Le Pro Feed sono canne rapide, elastiche e potenti, perfette per l'agonismo in acque commerciali, anche con l'uso del method feeder.

*Pro Feed are very quick rods, flexible and powerful, perfect for competitions in commercial waters, also with method feeder.*

CODE	Length (m)	Castin W	Weight (g)	Diameter (mm)	Sections
CAPRO01A	2,70			10,95	2+3 TIPS
CAPRO01B	3,00			12,00	2+3 TIPS
CAPRO01C	3,30	50	185	13,60	2+3 TIPS

**SOLD OUT**

FIBER GLASS TIP 2 oz.

FIBER GLASS TIP 1 1/2 oz.

FIBER GLASS TIP 1/2 oz.

**SOLD OUT**

Series: XT

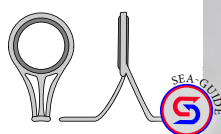

LEG: Medium  
STONE: Sic  
FRAME COLOR: Gun Smoke

Series: XM

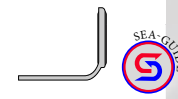

LEG: Micro Guides  
STONE: Sic  
FRAME COLOR: Gun Smoke



### EXTRA TIPS

CARBON

1oz (code: CATIP01)

1.1/2oz (code: CATIP01A)

2oz (code: CATIP01B)

2.1/2oz (code: CATIP01C)

3oz (code: CATIP01D)

4oz (code: CATIP01E)

FIBERGLASS

1/2oz (code: CATIP02A)

1oz (code: CATIP02B)

1.1/2oz (code: CATIP02C)

2oz (code: CATIP02D)

2.1/2oz (code: CATIP02E)

# NEXT ADVENTURE

## 2 SECTIONS



Series: XT



LEG: Medium  
STONE: Sic  
FRAME COLOR: Gun Smoke

Series: XY



LEG: Short  
STONE: Sic  
FRAME COLOR: Gun Smoke

Series: XM



LEG: Micro Guides  
STONE: Sic  
FRAME COLOR: Gun Smoke

## NEXT ADVENTURE 90GR.



MEDIUM POWER - ACTION 2

Un blank elastico e potente è quello che serve nella pesca a lunga distanza, quando si deve gestire con profitto ogni singola preda, anche con impianti di lenza leggeri, indipendentemente dalla sua taglia.

*A flexible and powerful blank for distance casting, when each single catch needs to be handled successfully, also with light line setup, regardless of size.*

CODE	Length (m)	Casting W. (gr)	cl.Length (cm)	Weight (gr)	Diameter (mm)	Sections
CANEX03A	3,60	90	186	197	12,60	2+3 TIPS
CANEX03B	3,90	90	186	226	13,20	2+3 TIPS

CARBON TIP 1 - 1/2 oz.  
  CARBON TIP 2 oz.

CARBON TIP 3 oz.

## NEXT ADVENTURE 60GR.



MEDIUM - ACTION 2

Lo sviluppo su due sezioni e l'azione rapida, seppur marcatamente progressiva, rende questi strumenti perfetti per la pesca agonistica, quando la velocità d'esecuzione è la carta vincente.

*The two sections structure and quick action, yet decidedly progressive, makes these tools perfect for tournament angling, when the trump card is speed of execution.*

CODE	Length (m)	Casting W. (gr)	cl.Length (cm)	Weight (gr)	Diameter (mm)	Sections
CANEX02A	3,30	60	169	172	11,40	2+3 TIPS
CANEX02B	3,60	60	185	186	12,40	2+3 TIPS

FIBER GLASS TIP 1 oz.  
  CARBON TIP 1 - 1/2 oz.

CARBON TIP 2 oz.

## NEXT ADVENTURE 25GR. - 35GR. - 45GR.

KT

LIGHT - ACTION 4

Create con tutto il nerbo necessario per la pesca veloce dei carpodromi, le nostre "commercial rods" si svelano in tutto il loro valore anche nelle pesca di ricerca alla corta e media distanza.

*Created for the power needed for fast fishing in carpdomes, our commercial rods shine and are extremely effective also in search fishing at short and medium casting distance.*

CODE	Length (m)	Casting W. (gr)	cl.Length (cm)	Weight (gr)	Diameter (mm)	Sections
CANEX01A	2,70	25	143	148	10,60	2+3 TIPS

 FIBER GLASS TIP 1 oz.  FIBER GLASS TIP 1 1/2 oz.

 FIBER GLASS TIP 1/2 oz.

CODE	Length (m)	Casting W. (gr)	cl.Length (cm)	Weight (gr)	Diameter (mm)	Sections
CANEX01B	3,00	35	159	157	11,00	2+3 TIPS

 FIBER GLASS TIP 1 oz.  FIBER GLASS TIP 1 1/2 oz.

 FIBER GLASS TIP 1/2 oz.







CODE	Length (m)	Casting W. (gr)	cl.Length (cm)	Weight (gr)	Diameter (mm)	Sections
CANEX01C	3,30	45	169	173	11,50	2+3 TIPS

 FIBER GLASS TIP 2 oz.  FIBER GLASS TIP 1 oz.





 FIBER GLASS TIP 1 1/2 oz.

## EXTRA TIPS

### CARBON

-  1oz (CODE: CATIP01)
-  1.1/2oz (CODE: CATIP01A)
-  2oz (CODE: CATIP01B)
-  2.1/2oz (CODE: CATIP01C)
-  3oz (CODE: CATIP01D)
-  4oz (CODE: CATIP01E)

### FIBERGLASS

-  1/2oz (CODE: CATIP02A)
-  1oz (CODE: CATIP02B)
-  1.1/2oz (CODE: CATIP02C)
-  2oz (CODE: CATIP02D)
-  2.1/2oz (CODE: CATIP02E)

# NEXT ADVENTURE

## PELLET FEEDER

È il pasturatore prediletto da chi pesca in carpodromo, dove manifesta tutta la sua efficienza, molto spesso superiore al methodfeeder, suo predecessore. Il pellet opportunamente bagnato, una volta pressato con moderazione dentro al contenitore insieme all'innesco, viene lanciato in acqua per essere aspirato dalla carpa, evento che sovente accade prima che il feeder tocchi il fondo.

*Favorite feeder for the carpodrome feeder fisherman, where it will perform at its best, often even better performing than the method feeder. The expanded pellets are loaded in the feeder along with the hook bait, carps will inhale the bait easily, often even before reaching the bottom.*

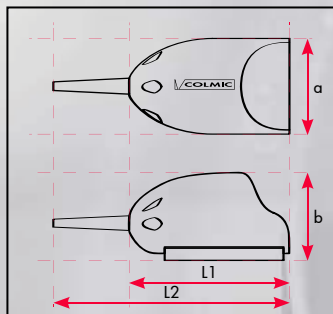

### SMALL

1 pcs per Bag

CODE	gr.	A	B	L1	L2
FED50A	20	25mm	21mm	40mm	64mm
FED50B	30				

### LARGE

1 pcs per Bag

CODE	gr.	A	B	L1	L2
FED50C	25	30mm	25mm	50mm	74mm
FED50D	40				



## STICKY MAGGOTS FEEDER

Evoluzione del Pellet feeder, lo Sticky Maggot Feeder è senz'altro il metodo più efficace, per non dire il più devastante, per la pesca del cavedano e del barbo. La sua forma è la più adatta a contenere del bigattino incollato, trattenuto in sede da un piccolo bordo perimetrale ricavato all'interno del feeder; il corpo forato permette l'afflusso controllato dell'acqua la quale, diluendo la colla, fa letteralmente esplodere verso l'esterno i bigattini e l'innesco che, nascosto fra questi, diventa indistinguibile ai sensi del pesce.

*The Sticky Maggot feeder is an evolution of the pellet feeder, fishing the sticky maggots feeder is a devastating technique for chub and barbel. It's perfectly shaped to hold sticky maggots, they're kept inside thanks to a special inner lip, the drilled body will allow a controlled water flow that will melt the glue and will "explode" the maggots and the hook bait out of the feeder, in this way the hook bait will remain hidden mixed with the other maggots.*

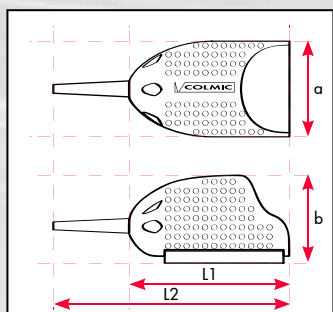

### LARGE

1 pcs per Bag

CODE	gr.	A	B	L1	L2
FED51A	25	30mm	25mm	50mm	74mm
FED51B	40				

### EXTRA LARGE

1 pcs per Bag

CODE	gr.	A	B	L1	L2
FED51C	30	35mm	28mm	58mm	82mm
FED51D	40				

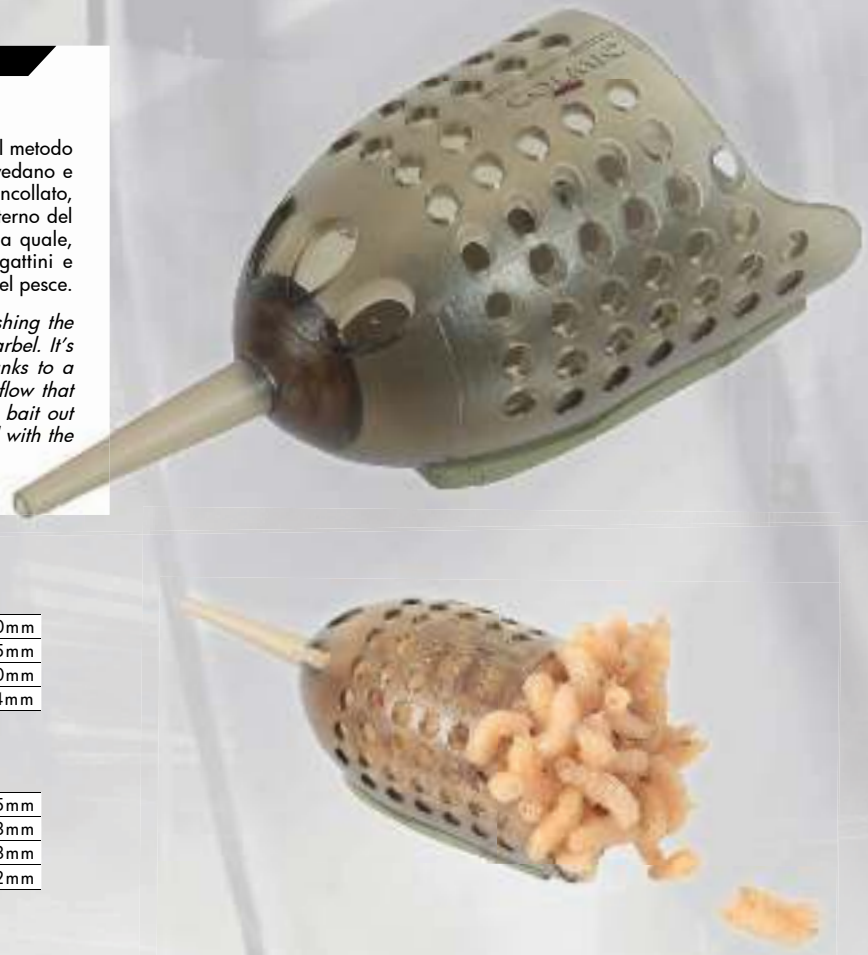



## CUP FEEDER

Method feeder a tazza per meglio contenere modeste quantità di pastura o pellet, con la certezza di avere sempre l'esca contenute fra la pastura o il pellet di brumeggio. Strumento perfetto per la pesca veloce alle carpe nelle acque commerciali, soprattutto nell'azione a corta distanza e in acque non troppo profonde.

*This scoop shaped method feeder will perfectly hold small amount of groundbait or pellets and will guarantee to keep the bait inside the mix. A perfect feeder for commercial fishery speed fishing for carps, especially at short distance and in shallow water.*

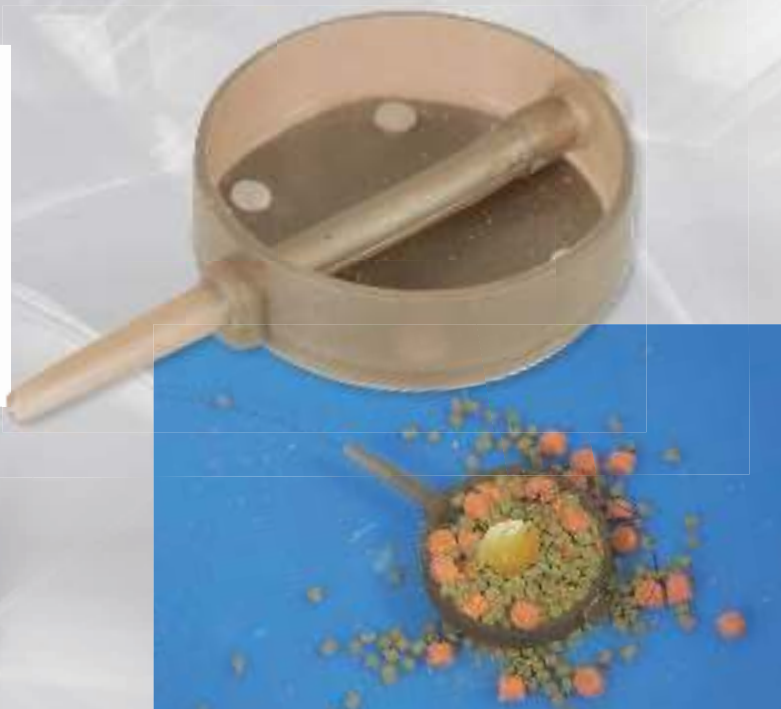

**SMALL**  
1 pcs per Bag

CODE	gr.
FED52A	20

**SIZES**

A	30mm
B	9,8mm
L1	33mm
L2	64mm

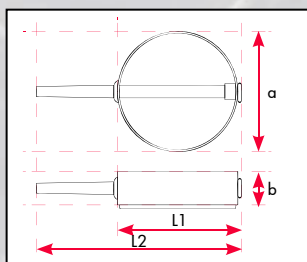

**MEDIUM**  
1 pcs per Bag

CODE	gr.
FED53A	30
FED53B	40

**SIZES**

A	36mm
B	9,8mm
L1	39mm
L2	63mm

## OPEN PELLET FEEDER

Pasturatore per pellet dotato di un'ampia apertura superiore, appositamente studiata per facilitare l'aspirazione dell'esca nascosta fra i granuli del pellet contenuto, da parte di quei pesci che, come le breme, mangiano in verticale sulla pastura.

*Wide mouth pellet feeder, expressly studied to allow a perfect inhaling of the bait mixed trough the pellets loaded in the feeder by vertically feeding fish species like bremes.*

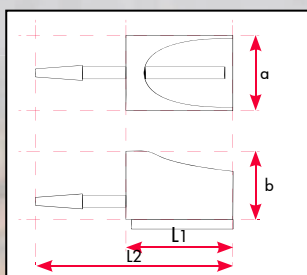

**SMALL**  
1 pcs per Bag

CODE	gr.
FED54A	20
FED54B	30

**SIZES**

A	25mm
B	23mm
L1	27mm
L2	65mm

**MEDIUM**  
1 pcs per Bag

CODE	gr.
FED55A	30
FED55B	40

**SIZES**

A	28mm
B	25mm
L1	35mm
L2	66mm

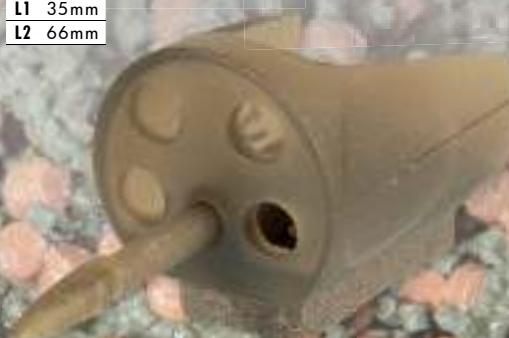

## DISTANCE NET FEEDER

Il pasturatore a "gabbietta" che, grazie alla sua forma e alla disposizione ideale dei pesi, consente di lanciare alle distanze superiori il suo contenuto e nel contempo, a non affondare nei fondali melmosi dei nostri canali. La forma anellare a tronco di cono della zavorra e la sua posizione in coda, sono l'ideale per una perfetta traiettoria di volo, mentre il materiale di costruzione, totalmente privo di piombo, è stato pensato in funzione del massimo rispetto per il pesce e per il suo habitat naturale.

*This cage feeder thanks to its special shape and the special weights distribution will allow long range casting and in the meantime it will not sink in silty bottom spots. The round conical shape and the positioning of the weight in the bottom part of the feeder will allow a perfect trajectory during the cast. The feeder is totally lead free and environmentally friendly.*

1pcs per Bag

CODE	gr.	Cage Sizes Ømm Hmm	
FED56A	20	26	25
FED56B	30	26	25
FED56C	40	26	25

CODE	gr.	Cage Sizes Ømm Hmm	
FED57A	20	28	31
FED57B	30	28	31
FED57C	40	28	31
FED57D	50	28	31

CODE	gr.	Cage Sizes Ømm Hmm	
FED58A	30	32	36
FED58B	40	32	36
FED58C	50	32	36

## BULLET NET FEEDER

Un vero "proiettile" da lunga gittata, indispensabile per raggiungere con precisione distanze estreme. Facile da caricare grazie ai due soli raggi di sostegno del piombo che permettono di comprimere il contenuto con la stessa mano, accoppiando due dita della stessa mano a cavallo del sostegno stesso, nella parte inferiore del feeder, mentre con il pollice si può pressare nella parte superiore.

*A real "long range" bullet, priceless to accurately reach very long distances. Easy to load thanks to its special design with only two ribs connections the lead to the feeder body and allowing to load the feeder with a single hand.*

1pcs per Bag

CODE	gr.	Cage Sizes Ømm Hmm	
FED59A	30	25	25
FED59B	40	25	25
FED59C	50	25	25

CODE	gr.	Cage Sizes Ømm Hmm	
FED60A	30	25	37
FED60B	40	25	37
FED60C	50	25	37
FED60D	60	25	37



## STANDARD CAGE FEEDER

Proposto in formasti diversi, per coprire ogni esigenza, lo Standard Cage Feeder è indispensabile quando serve un rilascio veloce del suo contenuto, magari creando anche lungo la colonna d'acqua quell'interessante scia di sapori, molto gradita al pesce. Ottimo quindi, per ogni circostanza di acqua ferma o moderatamente mossa. La sua zavorra totalmente priva di piombo (lead free) e la verniciatura a forno, sono stati pensati, tanto nei rispetti dell'ambiente, quanto per non "inquinare" minimamente il sapore del contenuto, facilmente alterabile dalle particelle di ossido.

*There are various types of Standard Cage Feeder to meet all requirements, and it is a must-have for quick release of its contents. It can also possibly create a scented trail in the water, which is extremely attractive to fish. It is therefore excellent in stillwater as well as moderately moving water. The completely lead-free ballast and the oven-baked coating have been designed with respect for the environment, and also not to "pollute" in any way the taste of the contents, which can be easily altered by oxides particles.*

1 pcs per Bag

CODE	gr.	Cage Sizes Ømm Hmm	
FED65A	15	20	25
FED65B	20	20	25
FED65C	25	20	25

CODE	gr.	Cage Sizes Ømm Hmm	
FED66A	20	20	31
FED66B	30	20	31

CODE	gr.	Cage Sizes Ømm Hmm	
FED67A	20	25	25
FED67B	30	25	25
FED67C	35	25	25

CODE	gr.	Cage Sizes Ømm Hmm	
FED68A	20	25	37
FED68B	30	25	37
FED68C	35	25	37
FED68D	45	25	37

CODE	gr.	Cage Sizes Ømm Hmm	
FED69A	30	28	37
FED69B	40	28	37
FED69C	45	28	37

CODE	gr.	Cage Sizes Ømm Hmm	
FED70A	30	28	50
FED70B	40	28	50
FED70C	50	28	50



## STARTING FEEDER

Nelle gare di feeder fishing è consentito alimentare lo spot solo per mezzo del pasuratore attaccato alla canna. Proprio per questo, abbiamo creato due misure di Starting Feeder regolamentari, ma di grosse dimensioni, capaci di "fare il fondo" con delle importanti quantità di brumeggio. Costruito con criteri di altissima qualità, abbiamo scelto di non corredare di zavorra lo Starting Feeder, proprio per dar modo al pescatore di scegliere in autonomia, se e quanto peso aggiungere di volta in volta al pasturatore, in relazione alle circostanze della propria stazione di pesca..

*In feeder competitions spot feeding is allowed only with the feeder attached to the rod. For this very reason, we created two large sized standard Starting Feeder, to "create a feeding area" for large quantity of bait. Built with the highest quality, we have decided not to equip the Starting Feeder with sinkers, for the specific purpose of letting the fisherman make a personal choice: whether to add weight and how much of it, by adding each time to the feeder, according to the specifics of different fishing spots*

### LARGE

1 pcs per Bag

CODE	Cage Sizes Ømm Hmm	
FED71A	40	61

### EXTRA LARGE

1 pcs per Bag

CODE	Cage Sizes Ømm Hmm	
FED71B	46	67





## CAGE FEEDER KOSTAL

I pasturatori (Feeder) Kostal sono del tipo "cage" (gabbia o gabbietta) e sono stati progettati per contenere sfarinati, ma nello stesso tempo, stretti fra due tappi di pastura, possono contenere un po' di tutto, come le varie granaglie, pellet, bigattini, ecc. ecc. La caratteristica principale dei pasturatori Kostal sta nella loro robustezza, che li rende di fatto praticamente indistruttibili.

### RECTANGULAR CAGE FEEDER

La forma del Rectangular Cage Feeder (pasturatore rettangolare a rete), è pensata per la pesca in corrente sostenuta poiché, grazie alla sua forma rettangolare, è meno soggetto al rotolamento, rispetto a un pasturatore di forma rotonda e quindi, anche se niente vieta di usarlo in acque ferme, il suo compito specifico è quello di tenere saldamente il fondo.

### ROUND CAGE FEEDER

Il Round Cage Feeder è il più classico delle "retine - gabbiette" e spetta al peso e alle dimensioni determinarne l'utilizzo, più o meno per come di seguito descritto:

1) Il normale Round Cage viene usato per veicolare i brumeggi (la pasturazione) usando, a seconda delle necessità del momento, i diversi pesi e volumi;

2) La versione with O-Ring altro non è che un normale Round Cage al quale è stato aggiunto un anello di gomma come connettore elastico, utile per ammortizzare lo shock di lanci particolarmente potenti.

*The Kostal swim feeders are "cage" style feeders, they have been expressly developed to hold ground baits but can be filled with different baits and mix closed between two ground baits tops, like pellets, maggots, corn, etc. The main features of the Kostal swim feeders are their strongness and durability, thanks to this they're nearly indestructible.*

### RECTANGULAR CAGE FEEDER

*The shape of the rectangular cage feeder is expressly developed for heavy flowing water fishing, thanks to their rectangular shape they're less inclined to rolling than a rounded shape one, hence they're developed for flowing water they works perfectly in still water, anyway their main feature is to hold firmly on the bottom.*

### ROUND CAGE FEEDER

*The Round Cage Feeder is the typical cage feeder and its specific use vary upon its size and the weight, see the scheme below:*

1) The standard Round Cage is used to feed on the particular momentary needs working on the different weights and volumes.

2) The O-Ring version is basically a standard Round Cage model with the addition of a rubber o-ring attachment acting as a shock absorber during the most powerful casts.

### RECTANGULAR CAGE FEEDER

5pcs per Bag

CODE	gr.	Size(mm)
FEDK023	15	22x32 h.37
FEDK024	20	22x32 h.37
FEDK025	25	22x32 h.37

CODE	gr.	Size (mm)
FEDK026	15	22x32 h.44
SOLD OUT	25	22x32 h.44
SOLD OUT	70	22x32 h.56



### ROUND CAGE FEEDER

5pcs per Bag

CODE	gr.	Size(mm)
FEDK006	15	Ø 25 h.44
FEDK010	50	Ø 25 h.44
FEDK011	60	Ø 25 h.44

CODE	gr.	Size(mm)
FEDK013	20	Ø 25 h.56
FEDK014	25	Ø 25 h.56
SOLD OUT	30	Ø 25 h.56
FEDK016	40	Ø 25 h.56
FEDK017	50	Ø 25 h.56
FEDK018	60	Ø 25 h.56
FEDK019	70	Ø 25 h.56
FEDK020	80	Ø 25 h.56

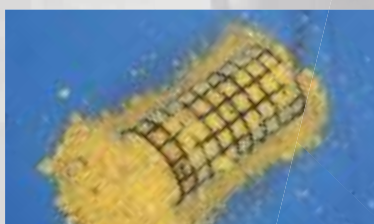

### ROUND CAGE FEEDER WITH O-RIN

5pcs per Bag

CODE	gr.	Size(mm)
FEDK036	15	Ø 25 h.32
FEDK037	20	Ø 25 h.32
FEDK038	30	Ø 25 h.32

CODE	gr.	Size(mm)
FEDK039	15	Ø 25 h.44
FEDK040	20	Ø 25 h.44
FEDK041	30	Ø 25 h.44



## FEEDER BLOCK



2pcs per Bag

CODE	gr.
FED15	40
FED16	60
FED17	80
FED18	100



## ROUND FEEDER



2pcs per Bag

CODE	gr.
SWR20	20
SWR30	30
SWR40	40

## FLAT FEEDER



1pcs per Bag

CODE	gr.
SWC20	20
SWC60	60

## FEEDER FK

2pcs per Bag

CODE	gr.
FED10	40
FED11	60
FED12	80
FED13	100



## FEEDER RD



3pcs per Bag

CODE	gr.	cm.	Color
FED30	4,0	6,0	Transparent
FED31	4,5	7,5	Transparent
FED32	4,5	9,0	Transparent

## FEEDER L3



1pcs per Bag

CODE	gr.	Lead
FED04	30	Yes
FED05	40	Yes



## BOXEVA KIT

CODE: BOXEVA25

Pratico e resistente, questo kit è quanto di meglio si possa chiedere in un rapporto di spazio-ingombro. Un recipiente con coperchio a cerniera dove conservare e trasportare la pastura già bagnata senza che questa perda il suo grado di umidificazione; una bacinella multiuso per bagnare e contenere sfarinati o incollare i bigattini; un setaccio con fori di 6 mm.; tutto questo raccolto e contenuto in un unico, comodo involucro.

*This practical and durable outfit is the perfect dimension/transport ratio kit. A groundbait bucket with zip top to transport moistured groundbait avoiding it to dry up; a multi use basin to prepare groundbait and to glue maggots; a 6 mm mesh siene; everything contained in a single practical container.*



Composto da: / Composed to:

- PVC: SRAPE W/COVER & LOOP (DIAM.35CM - H.13CM)**
- BACINELLA (DIAM.34CM - H.12CM - 5LT)**
- CERCHIO IN ALLUMINIO (DIAM.38CM - 1 CONNETTORE)**
- VAGLIO (33CM MAGLIA 6MM)**

## EVA ROD REST

CODE	Size
<b>A</b> AP23A	9 cm
<b>B</b> AP24A	30 cm
<b>C</b> AP24B	48 cm
<b>D</b> AP25A	BENT METHOD 37cm

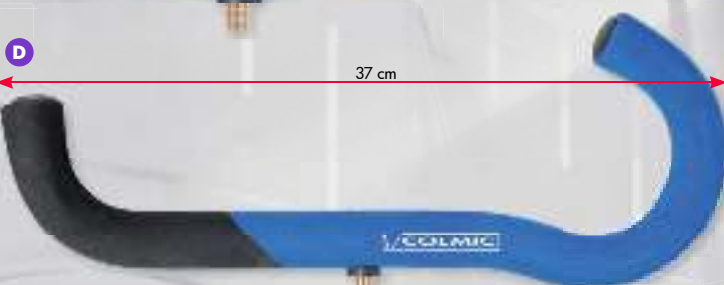
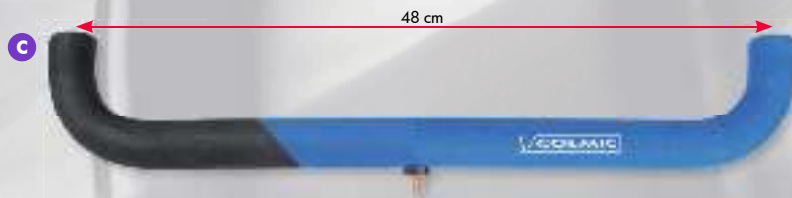
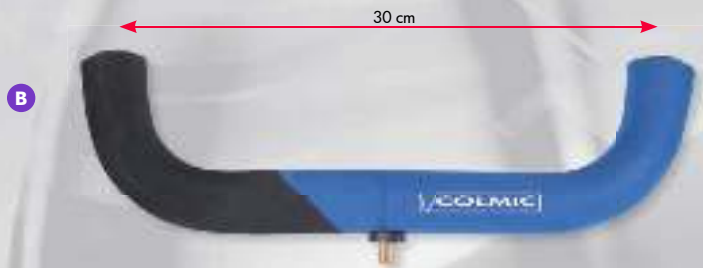

## FEEDER ARM

CODE: PA0951A

Braccio di sostegno telescopico a due punti d'appoggio, pratico, leggero e robusto, costruito in lega d'alluminio. La sezione quadrata del braccio tubolare garantisce una maggiore stabilità rispetto ad altri feeder arm di sezione rotonda. L'inclinazione del braccio è velocemente regolabile per mezzo di un unico, solido morsetto.

*Telescopic double anchoring points feeder arm, practice, light and durable, made of ultra light aluminium. The squared profile of the tubular arm will guarantee a better stability comparing to other round profile feeder arms. The arm inclination is quickly adjustable trough a single clamp.*

## ONE SIDE STRIKE ROD REST

CODE: AP20A



## SWING "V" ROD REST

CODE: AP21A



## TWO SIDE STRIKE ROD REST

CODE: AP20B



## SILICON ROD REST 190

CODE: AP22C

## SILICON ROD REST 140

CODE: AP22B

## SILICON ROD REST 110 "U" PART

CODE: AP22A



## SCRAPE GROUNDBAITS

Per ogni pastura destinata alla pesca al colpo, ivi compreso il feeder fishing, esiste una regola comune fondata sulla necessità di proporre al pesce un brumeggio ad effetto immediato, capace di intratterlo più a lungo possibile sul nostro spot di pesca e senza saziarlo. Nella pesca al colpo tradizionale, la fase della pasturazione viene gestita per mezzo di abbondanti quantità di terre e farine necessarie per creare un persistente tappeto di pascolo sul quale radunare il pesce e, grazie alle minuscole particelle di cibo, farcelo rimanere per molto tempo. Nella pesca con il feeder invece, il concetto di "abbondante" è pura utopia poiché la pastura che giunge sul fondo è solo quella contenuta di volta in volta nel pasturatore utilizzato e questo equivale a una mole di sfarinati mai superiore a 2 o 3 litri in cinque ore, a fronte dei 16/18 litri delle tre ore di una gara di pesca al colpo. Due principi diversi quindi, ma entrambi finalizzati allo stesso scopo: attrarre il pesce intorno alla nostra esca. Nel primo caso vale il criterio della quantità; nel secondo caso quello che conta è la qualità, quella stessa qualità di alto livello sulla quale si basa la complessa struttura di una pastura da feeder, la dove non sono ammessi prodotti dozzinali, ma solo ingredienti primari selezionati e miscelati in percentuali scientifiche, capaci di imprimere una forte connotazione attrattiva a un alimento bilanciato e sano, pensato per stimolare l'appetito del pesce, senza però saziarlo. Noi di Colmic abbiamo chiaro già da tempo il concetto pregnante della pasturazione con il feeder ed è per questo che oggi, dopo un serio periodo di studio e di analisi, siamo in grado di offrire al pescatore, anche a quello più esigente, la nostra nuova linea di pasture Scrape Feeder una selezione completa di sfarinati specifici, altamente performanti e pronti per ogni circostanza. Le pasture Scrape Feeder sono state una componente essenziale per il successo del Team Oltrarno Colmic che ha dominato l'edizione 2015 del Campionato Italiano a Squadre di Pesca a Feeder, portando così nella bacheca di casa Colmic un altro prestigioso Scudetto Tricolore.

*Every coarse fishing groundbait, including feeder ones, will need to respect the common rule of feed the fish with a immediate action mix able to keep them as long as possible on the fishing spot without satiating them. In traditional coarse fishing the feeding stage is made by feeding big amounts of limes and groundbaits, to obtain a consistent fishing ground where to attract and keep fish as long possible, thanks to the small bait particles. In feeder fishing instead the "abound" in feeding is pure utopia since the only ground bait arriving on the bottom is the one contained in the swim feeder cast after cast, and will never exceed the maximum quantity of 2 or 3 litres in a 5 hours session, compared to a 16/18 litres used in a 3 hours session in coarse fishing. Two totally different concepts, but focused on the same final result: to attract the fish close to to our bait. In coarse fishing is a matter of quantity, in feeder fishing is more a matter of quality, the high quality on which a perfect feeder mix is based on. A mix concept where cheap and ordinary ingredients are not allowed but only the top quality raw ingredients are selected and mixed in scientific percentages, a mix developed to stimulate the fish appetite without satiating it. At Colmic we are fully aware of this concept developing our own line of feeder mixes and after a deep and serious study and test period we are now able to offer to the fishermen, from the leisure fishermen to the more exigent match anglers, our new comprehensive line of high performance Colmic Scrape Feeder groundbaits.*

### FEEDER MIX KRILL

CODE: PCFED02A - 1KG

Non possiamo parlare di una selezione completa di pasture da feeder, senza avere in catalogo una miscela a base di Krill: il prodotto più versatile dell'intera gamma di farine di pesce, particolarmente gradito da tutti i pesci, sia grandi che piccoli, ma soprattutto perfettamente compatibile con ogni altro sfarinato della linea Scrape Feeder. Miscelato con la Feeder Mix Sweet Fishmeal, è un ottimo composto per carpe, breme e carassi mentre, usato allo stato puro o tagliato con la Mito Mix feeder, si è rivelato davvero eccellente per i grossi clarius pisani.

*A feeder groundbait selection will be not complete without a krill mix. The more versatile mix in the fish flour range, appreciated by any fish species of all sizes and perfectly compatible with all other mixes in the Scrape Feeder line. Mixed to the Feeder Mix Sweet Fishmeal it will be a fantastic carp, crucians and breme mix.*



### FEEDER MIX PREMIUM HALIBUT

CODE: PCFED02C - 1KG

Particolarmente indicata per cavedani, barbi e grosse carpe, questa pastura si esprime al meglio in tutte quelle condizioni in cui ciò che serve è un alimento energetico, anche quando dispensato in dosi modeste come quelle veicolabili con un feeder. Inoltre, gli aminoacidi che integrano i componenti della Feeder Mix Premium Halibut, spandendosi in acqua, creano un'importante messaggio alimentare che attrae il pesce e ne stimola l'appetito.

*Recommended for big carps, barbels, chubs; this groundbait will perform at its best when a energetic mix is required, even feeding in small amount trough a swim feeder. Besides of this the aminoacids contained in the Feeder Mix Premium Halibut released in the water will attract the fish and stimulate their appetite.*







## FEEDER MIX SWEET FISHMEAL

**CODE: PCFED02D - 1KG**

Non c'è pesce nelle nostre acque al quale non piaccia il gusto delicato, ma incisivo e persistente, di questa pastura alla carne dolce di pesce; un mix dove le proprietà stimolanti degli aminoacidi essenziali si fondono con il potere proteico della farina di pesce e le proprietà organolettiche dei carboidrati, dando vita a un alimento bilanciato e con alto potere adescante. Ogni specie di pesce dei nostri fiumi, laghi e canali è fortemente attratta dalla Sweet Fish Meal, la quale però si esprime al meglio con carpe, breme e carassi.

*No fish will resist to this delicate but in the same time intense and persistent fish flour sweet mix; the stimulating capacity of the aminoacids, the capacity power of the fish flour and the organoleptic properties of the carbohydrates will result in a perfectly balanced high catch rate mix. Every fresh water species will be attracted by the Sweet Fish Meal but it will excell on carps, breme and crucians.*



## FEEDER MIX HALIBUT - HEMP

**CODE: PCFED02E - 1KG**

*Le migliori farine di halibut e la canapa più pregiata sono gli ingredienti base di questa pastura, particolarmente indicata per le taglie forti dei nostri fiumi e canali. Il pesce percepisce i suoi effluvi anche da grandi distanze, grazie proprio alla scia di sapore rilasciata degli oli primari di canapa e halibut di cui questa pastura è ricca. Il suo colore naturale (marrone-verde) si integra perfettamente con ogni fondale e non infastidisce il pesce, nemmeno quello più timido. L'Halibut e Canapa della Feeder Mix Halibut Hemp è un preparato irresistibile per barbi e cavedani over size, grosse carpe e le mitiche breme "big brown".*

*The main ingredients of this groundbait are the best quality Halibut flour and hemp, particularly suitable for bigger species in canals and rivers. The fish will sense the scents from a long distance away thanks to the oils released by the hemp and halibut primary raw ingredients composing this mix. Its natural green-brown color will perfectly match any bottom kind and will not disturb the fish, even the spookiest one. This feeder mix will be irresistible to barbels, big chubs, big carps and big breme.*



## FEEDER MIX BETAINE

**CODE: PCFED02B - 1KG**

Al pari del Krill, la pastura alla Betaina della linea Scrape Feeder è un prodotto che non può mancare nel paniere di ogni buon feederman. La betaina è un potente aminoacido al quale tutti i ciprinidi sono sensibili e che assolve il suo ruolo agendo direttamente sui recettori remoti del pesce, stimolandone il senso dell'appetito. Particolarmente indicata per carpe, carassi e breme, la Feeder Mix Betaine è in grado di creare nel pesce quella perdurante frenesia alimentare necessaria per mantenere il pesce in pastura.

*Also a Betaine based mix couldn't miss from the Scrape Feeder range. Betaine is a powerful aminoacid all cyprinids are sensible to, acting on the remote receptors of the fish it will stimulate their appetite. Particularly effective on carps, breme and crucians, the Feeder Mix Betaine will stimulate to fish up to a feeding frenzy, keeping the fish on the feeding spot.*



### MITO MIX FEEDER

CODE: PCFED03A - 1kg



### MITO MIX METHOD

CODE: PCFED03B - 1kg

Progettate per integrare o tagliare i potenti mix della linea Scrape Feeder a base di farina di pesce e per modificarne all'occorrenza la meccanica, la Mito Mix Feeder e la Mito Mix Method, sono due ottime pasture all round, perfettamente bilanciate nei rapporti nutrizionali, possiamo dire che, la Mito Mix Feeder è una pastura con un normale potere legante, la Mito Mix Method, proprio in virtù delle suo impiego specifico, è decisamente più tenace.

*Developed to be supplemented and cut with the powerful fish flour mixes of the Scrape Feeder groundbaits line or to modify their feeding action. The Mito Mix Feeder and the Mito Mix Method are two perfect all round ground baits, perfect nutritionally balanced. The Mito Mix Feeder have a standard binding power, the Mito Mix Method due to its characteristics have a much more powerful binding power.*



### ADVENTURE FEEDER

CODE: PCFED04A - 1kg

Una ricetta, già pronta con cui pescare senza problemi per la pesca col feeder. Perfetta anche per essere miscelata con altre pasture o con semplici ingredienti base. È possibile personalizzare la miscela aggiungendo aromi o additivi per meglio orientare la propria pesca. Le particelle rosse e gialle aggiungono ulteriore potere attrattivo.

*A ready-made recipe for an easy feeder fishing. It can be combined with the other ground baits or with simple ingredients. It also possible to customize feeder basic with fragrances or additives if you want give your fishing a particular focus. The red and yellow small particles they further improve Feeder basic attracting power.*



2,00MM

### PREMIUM HALIBUT PELLET

CODE: PCFED01A - 700gr

Il potente messaggio alimentare dell'halibut è ormai riconosciuto da tutti i pesci presenti nelle nostre acque, che ne sono particolarmente attratti. il Micro pellet Scrape Feeder è un ottimo integratore da aggiungere secco in pastura, oppure da incollare, sempre a secco, insieme ai bigattini. Lasciato a bagno in acqua, pura o miscelata con altri insaporitori, fino a ottenere la giusta tenacia, è la soluzione vincente per la pesca con il method feeder o con il pellet feeder.

*The high feeding capacity of the Halibut scent is well know to fish that are very attracted by it. The Scrape Feeder Micro Pellets are perfect to be added to groundbaits or to be glued with maggots. Can be expanded with water eventually adding scents and used on method and pellet feeders.*



## FEEDER BREAM

CODE: PCMSF01 - 1kg

Pastura studiata per la pesca a Feeder, di altissima qualità, facile nella bagnatura, concepita per la pesca di grosse prede, come Breme, grossi Gardon, Carpe e Tinche. Si può adoperare nei laghi, nei canali e nei fiumi in acqua corrente, il suo colore, la sapidità, il profumo si diffonderà sott'acqua attirando prima e mantenendo poi per tutta la fase di pesca i pesci sul posto pasturato. Si possono aggiungere tutte le esche conosciute! Per laghi o canali con acqua bassa si consiglia di bagnarla un'ora prima dell'utilizzo, per acque profonde o veloci si consiglia una bagnatura minima di tre ore prima dell'uso. E' sempre consigliabile di passare tutto al setaccio.

*Groundbait of the highest quality created for feeder fishing, easy wetting, designed for big size catch, such as Bream, large Gardon, Carp and Tench. It can be used in lakes, canals and flowing water rivers, its colour, sapidity, the scent will spread under water and will first attract then keep all the fish in the chummed location throughout the angling. All known baits can be added! In lakes or canals with low water levels it is recommended wetting one hour, for deep or fast moving waters, it is recommended wetting for a minimum of three hours. It is always advisable to sift everything.*

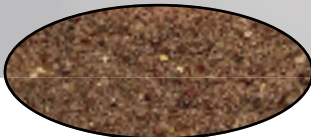
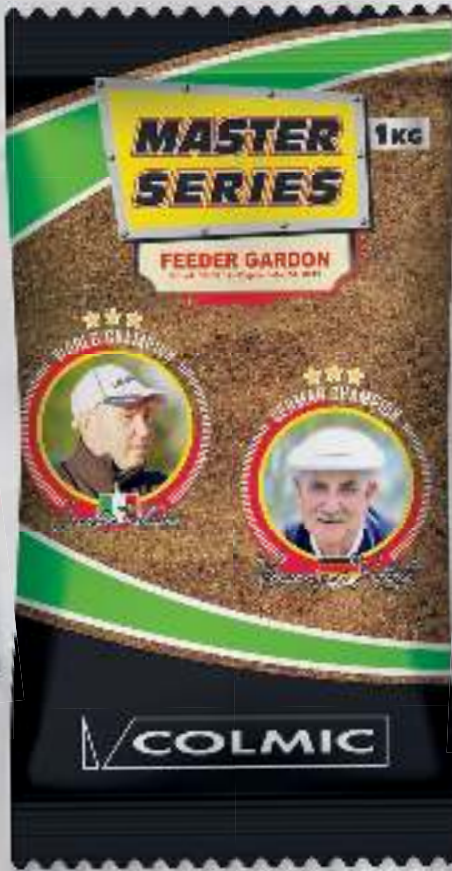

## FEEDER GARDON

CODE: PCMSF03 - 1kg

Pastura di altissima qualità, di studiata per la pesca a Feeder di colore marrone, concepita per la pesca ai Gardon. Per laghi o canali con acqua bassa si consiglia di bagnarla un'ora prima dell'utilizzo, per acque profonde o veloci si consiglia una bagnatura minima di tre ore prima dell'uso. La sapidità e il profumo specifico di speziato si diffonderanno sott'acqua attirando prima e mantenendo poi per tutta la fase di pesca i pesci sul posto pasturato. E' sempre consigliabile di passare tutto al setaccio.

*Highest quality brown colour groundbait created for Feeder fishing, easy wetting, created for Gardon fishing. In lakes or canals with low water levels it is recommended wetting one hour, for deep or fast moving waters it is recommended wetting for a minimum of three hours. Sapidity and the specific scent will spread under water and will first attract then keep all the fish in the chummed location throughout the angling. It is always advisable to sift everything.*

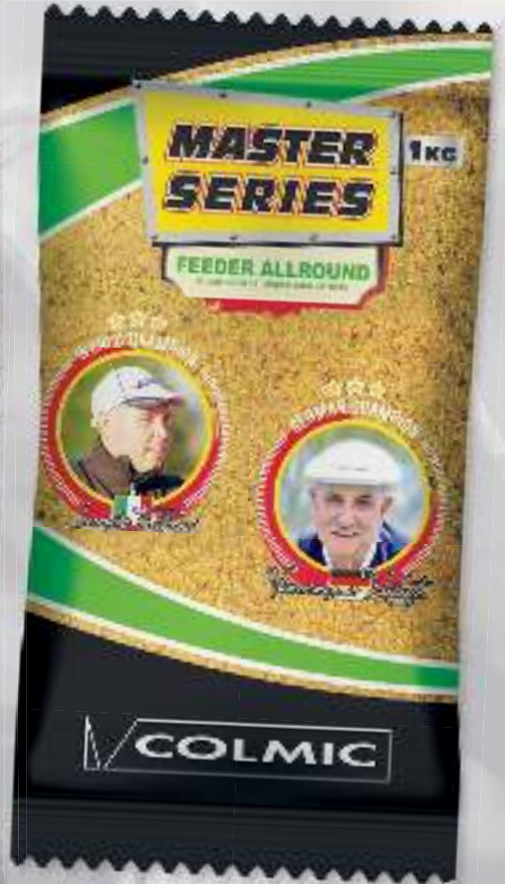

## FEEDER ALLROUND

CODE: PCMSF02 - 1kg

Pastura specifica per la pesca a Feeder di colore giallino naturale. E' una pastura che attira tutti i ciprinidi, specialmente le grosse Breme, grazie alla selezione di farine pesanti che non si disperdano sul fondo e restano vicinissimi al pasturatore proprio dove resta l'esca. E' una pastura tutto fare; si consiglia di impiegarla dove il pesce non è abituato agli aromi quando preferisce una pastura naturale. L'aggiunta di esche aumenterà il suo forte potere attrattivo. E' sempre consigliabile di passare tutto al setaccio.

*Cebo específico para la pesca con Cebador, de color amarillo natural. Es un cebo que atrae a todos los ciprinidos, especialmente a las grandes Breams, gracias a la selección de harinas pesadas que no se dispersan en el fondo y quedan muy cerca del cebador precisamente donde queda la carnaza. Es un cebo todoterreno; se recomienda emplearlo donde el pez no está acostumbrado a los aromas y cuando prefiere un cebo natural. La adición de carnazas aumentará su fuerte poder atractivo. Es recomendable siempre pasarlo todo por el tamiz.*

★ ★ ★ ★ ★  
**CHAMPION** ★ ★ ★ ★ ★  
 ★ ★ ★ ★ ★  
**FEED** ★ ★ ★ ★ ★



## FEEDER SPECIAL

**CODE: PCBEL03M - 1KG**

Pastura concepita per la pesca di grosse breme e carpe in acqua corrente. Il suo colore e profumo si diffonderà sott'acqua attirando prima e mantenendo poi i pesci sul posto.

*Groundbait especially conceived for fishing big bream and carps in running waters. Its color and its scent will spread underwater first attracting and then keeping the fishes in the same area.*



## FEEDER BASIC

**CODE: PCBEL03L - 1KG**

Una ricetta, già pronta con cui pescare senza problemi per la pesca col feeder. Perfetta anche per essere miscelata con altre paste Championfeed o con semplici ingredienti base. E' possibile personalizzare la miscela aggiungendo aromi o additivi per meglio orientare la propria pesca. Le particelle rosse e gialle aggiungono ulteriore potere attrattivo.

*A ready-made recipe for an easy feeder fishing. It can be combined with the other Championfeed ground baits or with simple ingredients. It also possible to customize feeder basic with fragrances or additives if you want give your fishing a particular focus. The red and yellow small particles they further improve Feeder basic attracting power.*

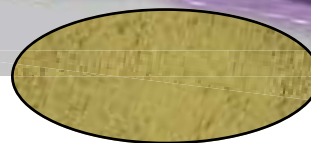

## SPECIAL GREEN

**CODE: PCBEL03N - 1KG**

Questa pastura, di colore verde, ha una struttura fine, la miglior farina di pesce, inclusa una bella dose di betaina. Questa miscela ne fa una perfetta pastura all round, può essere utilizzata per le carpe e breme. Nel feeder attrae immediatamente i pesci.

*This green fine grained ground bait features the best fish flour and a good dose of betaine. This mix makes Special 'G' Method Mix a perfect all round ground bait, ideal for carps and crucians. Its attractive effect is immediate.*

## SBP UMIDO

Si dice sia una pasturazione ideale quella che riesce a mantenere il pesce sullo spot di pesca inducendolo alla frenetica ricerca del cibo, ma senza sfamarlo. Per ottenere questo effetto Colmic offre al pescatore più attento ai particolari la sua nuova linea di SBP (Slow Breakup Pellet): un pellet naturale a base di mais cotto e finemente sminuzzato che, una volta spanto sul fondo, diffonde lentamente i suoi aromi, richiamando il pesce con il suo effetto costante e duraturo. Ottimo da usare da solo o come "particle" per arricchire starinati complessi, l'SBP Umido è un alimento naturale, certamente molto apprezzato da tutti i pesci d'acqua dolce, proposto da Colmic in tre diversi gusti: Canapa-Mais, Fragola e Mais.

*The perfect feeding will be the one keeping the fish on the fishing spot and stimulating it to feed as much as possible without saturating it. To obtain this result Colmic offer to the more demanding fishermen the SBP line (Slow Breakup Pellet); a natural Pellet made of cooked corn and finely minced that once it will be released on the bottom it will slowly spread its scent, attracting the fish trough its durable and effective effect. Perfect to add "particles" to the different mixes, the SBP is a natural and highly appreciated by all fresh water fish, available in three different scents: Hemp-Corn, Strawberry and Corn.*



### SBP UMIDO FRAGOLA 200GR

CODE: PCCA05A



### SBP UMIDO MAIS 200GR

CODE: PCCA05B



### SBP UMIDO MAIS/CANAPA 200GR

CODE: PCCA05C



## DUMBELLS E MINI BOILES

Sempre più feederman affrontano le loro sessioni di pesca rivolte ai grandi pesci, avvalendosi di esche come le Mini Boiles e i Dumbells, sia per l'alto potere adescante, sia per la loro consistenza che le rende meno accessibili al pesce di disturbo, lasciando più spazio per quello di taglia, il quale risulta essere particolarmente attratto dall'alone aromatico, denso e persistente, che queste esche rilasciano una volta in acqua. Perfette per essere innescate sull'hair rig, sia le Mini Boiles che i Dumbells hanno una densità ottimale per essere forate con il solo ausilio dell'ago, oppure, nel caso dei dumbells, fissate all'hair rig per mezzo degli anellini di caucciù.

Le Mini Boiles e di Dumbells vengono proposti nelle versioni "Affondante" e "Pop Up Dippate".

I Dumbells Affondanti sono disponibili nei gusti di: Krill, Tutti i Frutti, Lime-Menta e Mais;

i Dumbells Pop Up Dippati sono disponibili nei gusti di: Fragola e Mais;

le Mini Boiles Affondanti sono disponibili nei gusti di: Krill, Mais e Fragola;

le Mini Boiles Pop Up sono disponibili nei gusti di: Lime-Menta e Tutti i Frutti.

*More and more Feeder fishermen fish for big species using Mini Boiles and Dumbells hook pellets, because of their attracting power and their consistency that keep smaller fish away and avoid beeing disturbed by them favoring the bigger specimens. Bigger fish will be particularly attracted by the aromatic and persistent scent released in the water. Perfect to be hair rigged, both the Dumbells and the Mini Boiles have the perfect consistency to be drilled or pierced by a needle. The Dumbells will be perfectly banded trough the proper rubber bands.*

*The Mini Boiles and the Dumbells are available in the Sinking and Dipped Pop Up versions:*

*Dumbells affondanti (sinking): available in Krill, Tutti Frutti, Lime Mint and Corn scents.*

*Dipped Pop Up Dumbells: available in Strawberry, Corn scents.*

*Mini Boiles Affondanti (sinking): available in Krill, Corn, Strawberry scents.*

*Mini Boiles Pop Up: available in Lime Mint, Tutti Frutti scents.*



**DUMPELL AFFONDANTE  
KRILL 8-10MM / 50GR**

CODE:PCCA01A



**DUMPELL AFFONDANTE  
TUTTI FRUTTI 8-10MM / 50GR**

CODE:PCCA01B



**DUMPELL AFFONDANTE  
LIME MENTA 8-10MM / 50GR**

CODE:PCCA01C



**DUMPELL AFFONDANTE  
MAIS 8-10MM / 50GR**

CODE:PCCA01D



**DUMPELL POP UP DIPPATE  
FRAGOLA 10-14MM / 30GR**

CODE:PCCA02A



**DUMPELL POP UP DIPPATE  
MAIS 10-14MM / 30GR**

CODE:PCCA02B



**MINI BOILES AFFONDANTE KRILL** 10MM / 50GR

CODE:PCCA03A

**MINI BOILES AFFONDANTE MAIS** 10MM / 50GR

CODE:PCCA03B

**MINI BOILES AFFONDANTE FRAGOLA** 10MM / 50GR

CODE:PCCA03C



**MINI BOILES POP UP DIPPATE LIME MENTA** 10MM / 50GR

CODE:PCCA04A



**MINI BOILES POP UP DIPPATE TUTTI FRUTTI** 10MM / 50GR

CODE:PCCA04B



# WORLD DISTRIBUTOR

## **VALLE D'AOSTA PIEMONTE**

### **Alberto Varesini**

348 4443595 - albertovaresini@colmic.it

## **LOMBARDIA**

(province: BG-BS-CR-MN)

### **Stefano Premoli**

334 9415339 - s.premoli@colmic.it

(province: CO-LC-MI-PV-SO-VA-LO-MB)

### **Stefano Negri**

335 7108567 - stefanonegri@colmic.it

## **TRENTINO ALTO ADIGE, FRIULI VENEZIA GIULIA, VENETO**

### **Alessandro Cavallini**

335 6824124 - sandro.cavallini55@alice.it

## **EMILIA ROMAGNA**

(province: PR-PC)

### **Stefano Premoli**

334 9415339 - s.premoli@colmic.it

(province: BO-FO-MO-RA-RN)

### **Gian Franco Reali**

3483417532 - gianfrancoreali@colmic.it

(province: FE)

### **Alessandro Cavallini**

335 6824124 - sandro.cavallini55@alice.it

## **LIGURIA**

### **Alberto Varesini**

348 4443595 - albertovaresini@colmic.it

## **TOSCANA**

(province: FI-PT-PO)

### **Gianluca Meniconi**

335 7797140 - gianlucameniconi@colmic.it

(province: AR- LU-MS-GR-PI-LI-SI)

### **Alessandro Degl'Innocenti**

3355329609 - alessandrodeglinnocenti@colmic.it

## **UMBRIA - MARCHE**

### **Gianluca Zampa**

3356284642 - gianlucazampa@alice.it

## **LAZIO**

(province: VT-RI)

### **Gianluca Zampa**

3356284642 - gianlucazampa@alice.it

(province: LT-RM-FR)

### **Natalino Sarra**

337766453 - natalinosarra@colmic.it

## **ABRUZZO - MOLISE**

### **Tommaso Polidoro**

3404872400 - t.polidoro@colmic.it

## **CAMPANIA**

### **Clemente Carlino**

3939334670- clementecarlino@colmic.it

## **PUGLIA**

(provincia: FG)

### **Tommaso Polidoro**

3404872400 - t.polidoro@colmic.it

(province: BA-BR-LE-TA-BT)

### **Surano Pantaleo Fernando**

3485823541 - surano.fernando@libero.it

## **BASILICATA**

### **Iannuzzi Ruggero**

3397979499 - ruggeroiannuzzi@colmic.it

## **CALABRIA**

### **Salvatore Barberio**

3386421502 - calabriapesca@hotmail.it

(province: CO - KR)

### **Iannuzzi Ruggero**

3397979499 - ruggeroiannuzzi@colmic.it

## **SICILIA**

### **Gianluca Burtone**

3668026124 - gianlucaburtone@colmic.it

## **SARDEGNA**

### **Pierluigi Corrias**

3357757170 - pierluigicorrias@colmic.it

## **SPAIN**

### **Juan Antonio Rodriguez Blasco**

Madrid - Castilla de Mancha - Jaen

0034 616006115 - jarblasco@gmail.com

### **Antonio Jesus Escano Delgado**

Aragon - Cataluna

0034 635522169 - antonioesca@hotmail.com

### **Juan Francisco Marin Duran**

Caceres - Badajoz - Cordoba

0034 650067858 - richar\_colmic@hotmail.com

### **Jesus Francisco Hernando Manso**

Asturia - Castilla y Leon - Cantabria - Pais Vasco - La Rioja - Navarra

0034 617376166 - marnacu@gmail.com

### **Joaquin Vicente Ojeda Cantos**

Huelva - Cadiz - Malaga - Granada - Almeria - Sevilla

0034 680135140 - jojedacanto@hotmail.com

### **Angel Chao Perez**

La Coruña - Lugo - Orense - Pontevedra - Asturias

0034 656550186 - angelchaop@gmail.com

### **Antonio Jose Perez Peñalver**

Comunidad Valenciana - Murcia

0034 649900608 - elpalomo@gmail.com

## **PORTUGAL**

### **Joaquim Miguel Castanha Pinto**

00351 938538865 - colmic@sapo.pt

## **FRANCE**

### **Loyez Sebastien**

Departements:

01-02-03-08-10-14-16-17-18-21-22-23-24-25-27-28-29-33-35-36-37-39-41-42-44-45-47-49-50-51-52-53-54-55-56-57-58-59-60-61-62-66-67-68-69-70-71-72-75-76-77-78-79-80-84-85-86-87-88-89-90-91-92-93-94-95

0033 665364516 - loyez-sebastien@hotmail.fr

### **Nicolas Bachevalier**

Departements:

04-05-06-07-09-11-12-13-15-19-26-30-31-32-34-38-40-43-46-48-63-64-65-73-74-81-82-83

0033 632366821 - b.nicolas@live.fr

## **BELGIUM - LUXEMBURG HOLLAND**

### **Domenico Tomei**

0032 477373631 - domenicotomei@colmic.it

## **GERMANY**

### **Roberto Mazzasette**

Gebiet 0 - Gebiet 1 - Gebiet 2-Gebiet 3 n.32/33-30/31-38-39-34-37 - Gebiet 4 N.48-49 - Gebiet 9 - Gebiet 8 N.82-83-84-85-86-87-80/81

0049 1706375471 - roberto@colmic.it

### **Kai Sheppach**

Gebiet 3 N. 35 - Gebiet 4 N.46/47-44-45-41-40-42  
Gebiet 5 - Gebiet 6 - Gebiet 7 - Gebiet 8 N. 89-88

0049 1703222735 - kai@colmic.it

## **AUSTRIA**

### **Roberto Mazzasette**

0049 1706375471 - roberto@colmic.it

## **UNITED KINGDOM**

### **Northern of England - Scotland - Ireland**

sales1@colmic.it

### **Midlands - Wales**

sales2@colmic.it

### **Southern - England - London**

sales3@colmic.it

ALBANIA

ALGERIA

AUSTRALIA

BELARUS

BRASIL

BOSNIA HERZEGOVINA

BULGARY

CYPRUS

CROATIA

CZECH REP.

DENMARK

EGYPT

ESTONIA

FINLAND

GREECE

HUNGARY

IRAN

ISRAEL

LATVIA

LITHUANIA

MACEDONIA

MALTA

MAROCCO

NORWAY

POLAND

ROMANIA

RUSSIA

SERBIA

SINGAPORE

SLOVAKIA

SLOVENIA

SWISS

SWEDEN

UAE

UKRAINE

TUNISIA

TURKEY





**COLMIC ITALIA S.p.A.**  
**Loc. Ruota al Mandò - 50068 Reggello (FI)**  
**Tel. (+39) 055 8657079 - Fax (+39) 055 8657174**  
**Email: [colmic@colmic.it](mailto:colmic@colmic.it)**  
**Web site: [www.colmic.it](http://www.colmic.it)**

